

RLD10 0° detector head

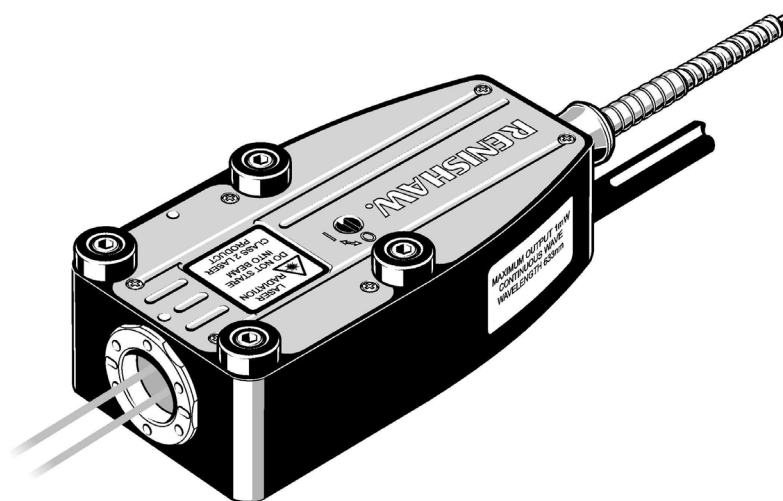

For the fibre optic laser encoder

Renishaw's RLE fibre optic laser encoder uses interferometry to provide high resolution, high linearity position feedback.

The RLE system comprises an RLU laser unit and one or two RLD detector heads. This data sheet describes the RLD 0° detector head.

The detector head is the core of the optical measuring system containing the interferometer, reference optics, fringe detector, laser shutter and beam steerer.

To complete the interferometer configuration, only one additional optic is required in either plane mirror or retroreflector based configurations. For easy installation, the integral rotary beam steerer allows final adjustments to be made to optimise beam alignment after the head has been secured.

The head dissipates negligible power (< 2 W) and is designed to be thermally stable.

Two versions of the RLD 0° head are available, one of which incorporates a plane mirror interferometer (PMI), the other a retroreflector interferometer (RRI). The fibre optic cable can be disconnected from the detector unit and the electrical cable can be disconnected from the laser head, thus allowing each to be pulled through small cable tracks and ducting. The detector head incorporates a safety interlock that prevents a laser beam being emitted if either the fibre or electrical cable are disconnected.

General outline and dimensions

Dimensions in mm (inches)

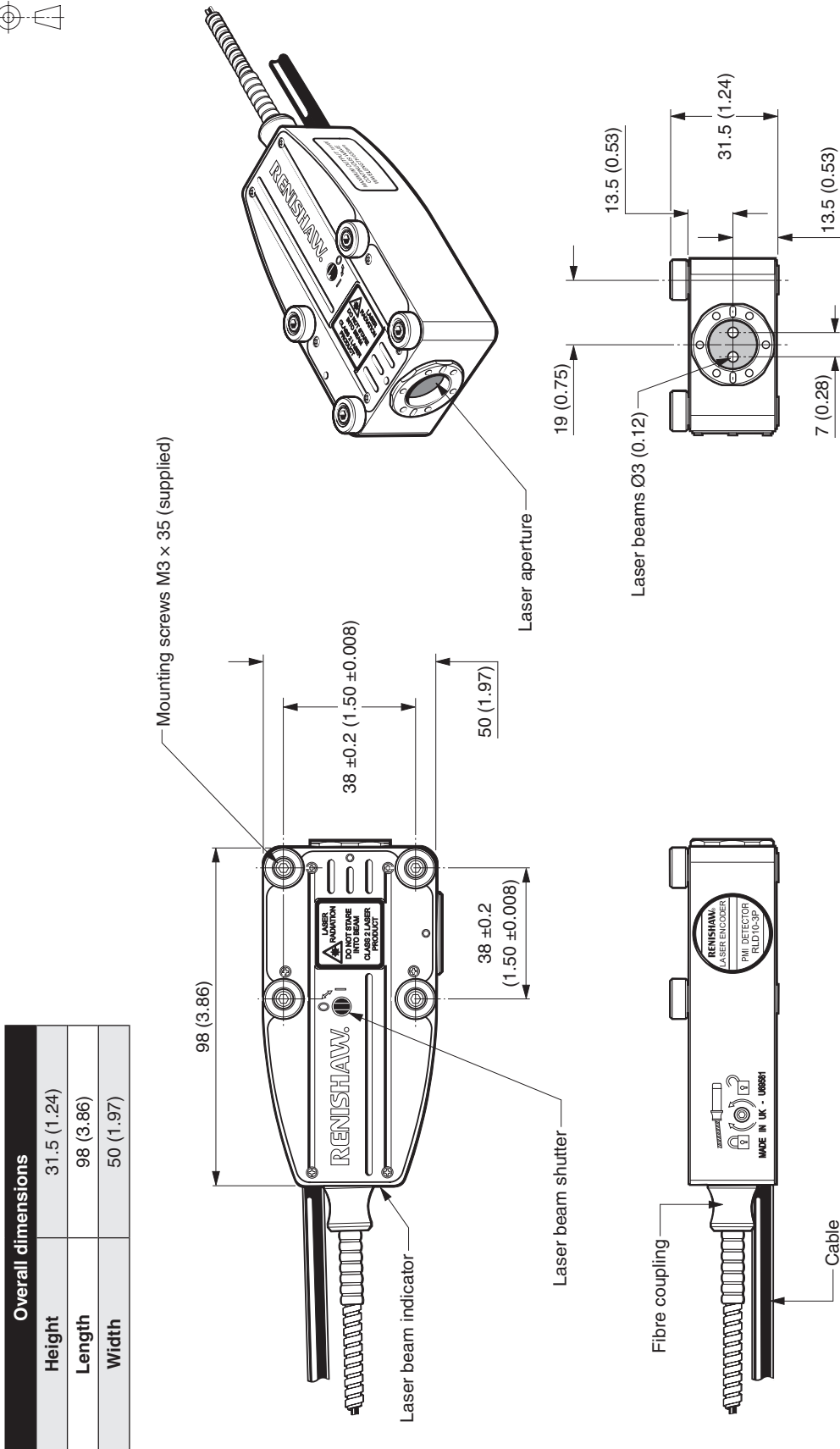

NOTES:

- The RLD 0° detector head can be mounted on either top or bottom faces providing maximum flexibility.
- Fixing: 4 off M3 x 0.5 x 35 mm or 5-40-UNC x 1 1/8 cap head screws on a 38 mm square pitch.

RLD10 0° detector head operating parameters

Axis travel	PMI	0 m to 1 m
	RRI	0 m to 4 m
Optical signal period	PMI	$\lambda/4$ (158 nm)
	RRI	$\lambda/2$ (316 nm)
System non-linearity error (SDE) ¹	PMI	< ± 2.5 nm below 50 mm/sec with > 70% signal strength < ± 7.5 nm at 1 m/sec with > 50% signal strength
	RRI	< ± 5 nm below 100 mm/sec with > 70% signal strength < ± 13 nm at 2 m/sec with > 50% signal strength
Thermal drift coefficient	< 100 nm/°C	Measured by mounting mirror and detector close together on a Zerodur® base and changing the temperature
Beam diameter	3 mm	
Beam separation	7 mm	Centre to centre
Beam alignment adjustment	$\pm 0.65^\circ$ pitch $\pm 1.5^\circ$ yaw	Integrated beam steering to simplify beam alignment
Beam alignment tolerance for plane mirror (1 m axis)	± 25 arcseconds	Tolerance applies to both pitch and yaw during operation
Cable length (standard)	3 m	Permanent attachment to the detector head and 15-way D-type connector at the laser
Cable diameter	6.5 mm	Terminated with a 15-way D-type connector
Fibre diameter (armoured)	5 mm	Removable from the detector head (connector 12 mm diameter)
Component weight	0.25 kg	
Operating environment		
	Pressure 650 mbar to 1150 mbar	Normal atmospheric
	Humidity 0% to 95% RH	Non-condensing
	Temperature 10 °C to 40 °C	

Zerodur® is a registered trademark of Schott Glass Technologies

It is possible to operate an RLE system at axis lengths greater than those stated in the table above, although the resulting signal strength will be affected by axis length, system velocity and optical alignment.

Legislative - Laser safety:

In accordance with IEC/EN60825-1, IEC/EN60825-2 and US standards 21CFR 1040 and ANSI Z136.1, Renishaw RLE lasers are Class II lasers and safety goggles are not required, since the blink reaction of a human will protect the eye from damage. Do not stare into the beam or shine it into the eyes of others. It is safe to view a diffuse-reflected beam. Do not dismantle the unit in any way; doing so may expose laser radiation in excess of Class II limits.

¹ Excludes interface.

Laser beam alignment

The RLD 0° detector head incorporates a beam steerer to simplify the alignment process. Prior to installation, ensure that the alignment grooves are horizontal and that both locking screws are loose, as shown in Figure 1. Align the head on the 4 mounting screws by securing one of the two nearest the aperture and rotate (yaw) the detector head until the maximum output signal strength is achieved. To then increase the output signal strength to its optimum, rotate the beam steerer using the key, as shown in Figure 1 to adjust the pitch. Finally, tighten the locking screw on the top side and 4 fixing screws.

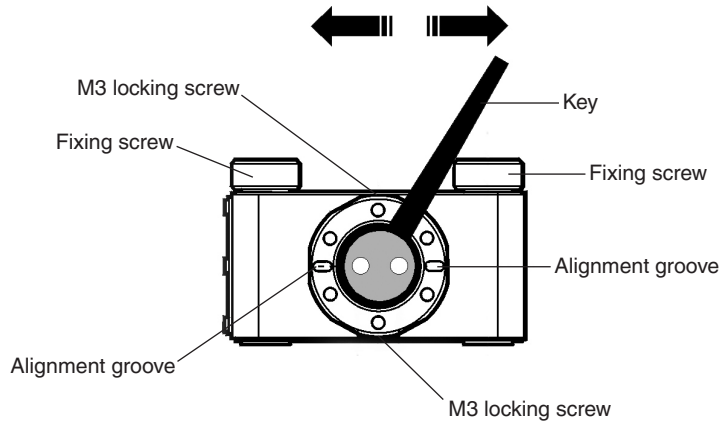
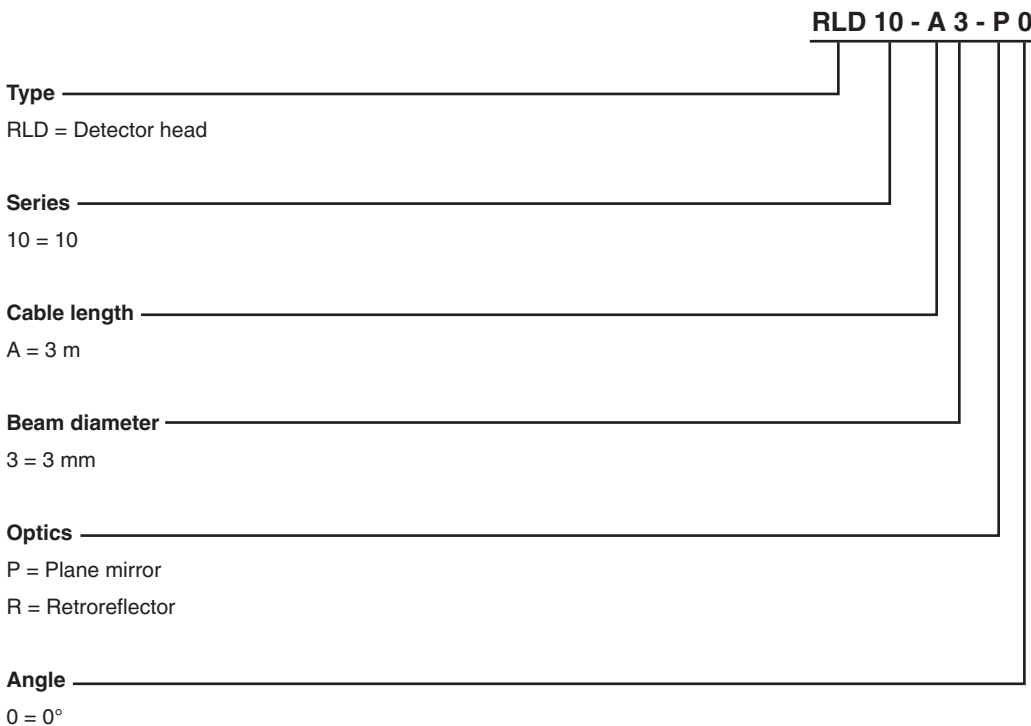

Figure 1

RLD identification and ordering

The RLD is normally supplied with the appropriate RLU laser unit as a configured RLE fibre optic laser encoder system. For full details of available RLE system configurations visit www.renishaw.com/laserencoders or consult your local Renishaw representative. For special applications or spares requirements, the RLD is available separately; the generic form RLD detector head part number is shown below:

Part number



www.renishaw.com/contact



#renishaw

 +44 (0) 1453 524524

 uk@renishaw.com

© 2001–2026 Renishaw plc. All rights reserved. This document may not be copied or reproduced in whole or in part, or transferred to any other media or language by any means, without the prior written permission of Renishaw.

RENISHAW® and the probe symbol are registered trade marks of Renishaw plc. Renishaw product names, designations and the mark 'apply innovation' are trade marks of Renishaw plc or its subsidiaries. Other brand, product or company names are trade marks of their respective owners.

WHILE CONSIDERABLE EFFORT WAS MADE TO VERIFY THE ACCURACY OF THIS DOCUMENT AT PUBLICATION, ALL WARRANTIES, CONDITIONS, REPRESENTATIONS AND LIABILITY, HOWSOEVER ARISING, ARE EXCLUDED TO THE EXTENT PERMITTED BY LAW. RENISHAW RESERVES THE RIGHT TO MAKE CHANGES TO THIS DOCUMENT AND TO THE EQUIPMENT, AND/OR SOFTWARE AND THE SPECIFICATION DESCRIBED HEREIN WITHOUT OBLIGATION TO PROVIDE NOTICE OF SUCH CHANGES.

Renishaw plc. Registered in England and Wales. Company no: 1106260. Registered office: New Mills, Wotton-under-Edge, Glos, GL12 8JR, UK.

Part no.: L-9904-2348-06-A

Issued: 05.2026