

# RESOLUTE™ RELA30/RSLA30 high-accuracy absolute linear encoder system



This page is intentionally left blank.

## Contents

Legal notices . . . . .	4
Storage and handling . . . . .	6
RESOLUTE readhead installation drawing – standard cable outlet . . . . .	8
RESOLUTE readhead installation drawing – side cable outlet. . . . .	9
RELA30/RSLA30 scale installation drawing – adhesive mounted. . . . .	10
Equipment required for adhesive mounting the RELA30/RSLA30 scale . . . . .	11
Installing the adhesive mounted RELA30/RSLA30 scale . . . . .	12
RELA30/RSLA30 scale installation drawing – clip and clamp mounted . . . . .	14
Equipment required for clip and clamp mounting the RELA30/RSLA30 scale . . . . .	15
Installing the clip and clamp mounted RELA30/RSLA30 scale . . . . .	16
RESOLUTE readhead mounting and alignment. . . . .	18
RESOLUTE readhead signals . . . . .	19
RESOLUTE readhead termination options . . . . .	22
Siemens DRIVE-CLiQ interface drawing – single readhead input . . . . .	24
Electrical connections. . . . .	25
General specifications . . . . .	27
RELA30 spar scale specifications . . . . .	28
RSLA30 spar scale specifications . . . . .	29

## Legal notices

### Patents

Features of Renishaw's encoder systems and similar products are the subjects of the following patents and patent applications:

CN1260551	EP2350570	JP5659220	JP6074392	DE2390045
DE10296644	JP5480284	KR1701535	KR1851015	EP1469969
GB2395005	KR1630471	US10132657	US20120072169	EP2390045
JP4008356	US8505210	CN102460077	EP01103791	JP5002559
US7499827	CN102388295	EP2438402	US6465773	US8466943
CN102197282	EP2417423	JP5755223	CN1314511	US8987633

### Terms and conditions and warranty

Unless you and Renishaw have agreed and signed a separate written agreement, the equipment and/or software are sold subject to the Renishaw Standard Terms and Conditions supplied with such equipment and/or software, or available on request from your local Renishaw office.

Renishaw warrants its equipment and software for a limited period (as set out in the Standard Terms and Conditions), provided that they are installed and used exactly as defined in associated Renishaw documentation. You should consult these Standard Terms and Conditions to find out the full details of your warranty.

Equipment and/or software purchased by you from a third-party supplier is subject to separate terms and conditions supplied with such equipment and/or software. You should contact your third-party supplier for details.

### Declaration of Conformity

Renishaw plc hereby declares that the RESOLUTE™ encoder system is in compliance with the essential requirements and other relevant provisions of:

- the applicable EU directives
- the relevant statutory instruments under UK law



The full text of the declaration of conformity is available at: [www.renishaw.com/productcompliance](http://www.renishaw.com/productcompliance).

### Compliance

#### Federal Code Of Regulation (CFR) FCC Part 15 – RADIO FREQUENCY DEVICES

##### 47 CFR Section 15.19

This device complies with part 15 of the FCC Rules. Operation is subject to the following two conditions: (1) This device may not cause harmful interference, and (2) this device must accept any interference received, including interference that may cause undesired operation.

##### 47 CFR Section 15.21

The user is cautioned that any changes or modifications not expressly approved by Renishaw plc or authorised representative could void the user's authority to operate the equipment.

##### 47 CFR Section 15.105

This equipment has been tested and found to comply with the limits for a Class A digital device, pursuant to part 15 of the FCC Rules. These limits are designed to provide reasonable protection against harmful interference when the equipment is operated in a commercial environment.

This equipment generates, uses, and can radiate radio frequency energy and, if not installed and used in accordance with the instruction manual, may cause harmful interference to radio communications. Operation of this equipment in a residential area is likely to cause harmful interference in which case the user will be required to correct the interference at his own expense.

## 47 CFR Section 15.27

This unit was tested with shielded cables on the peripheral devices. Shielded cables must be used with the unit to ensure compliance.

## Supplier's Declaration of Conformity

### 47 CFR § 2.1077 Compliance Information

**Unique Identifier:** RESOLUTE

### Responsible Party - U.S. Contact Information

Renishaw Inc.  
 1001 Wesemann Drive  
 West Dundee  
 Illinois  
 IL 60118  
 United States  
 Telephone number: +1 847 286 9953  
 Email: [usa@renishaw.com](mailto:usa@renishaw.com)

### ICES-003 – Information Technology Equipment (including Digital Apparatus)

This ISM device complies with Canadian ICES-003(A).

Cet appareil ISM est conforme à la norme ICES-003(A).

## Intended use

The RESOLUTE encoder system is designed to measure position and provide that information to a drive or controller in applications requiring motion control. It must be installed, operated, and maintained as specified in Renishaw documentation and in accordance with the Standard Terms and Conditions of the Warranty and all other relevant legal requirements.

## Further information

Further information relating to the RESOLUTE encoder range can be found in the RESOLUTE data sheets. These can be downloaded from our website [www.renishaw.com/resolutedownloads](http://www.renishaw.com/resolutedownloads) and are also available from your local Renishaw representative.

## Packaging

The packaging of our products contains the following materials and can be recycled.

Packing component	Material	ISO 11469	Recycling guidance
Outer box	Cardboard	Not applicable	Recyclable
	Polypropylene	PP	Recyclable
Inserts	Low density polyethylene foam	LDPE	Recyclable
	Cardboard	Not applicable	Recyclable
Bags	High density polyethylene bag	HDPE	Recyclable
	Metallised polyethylene	PE	Recyclable

## REACH regulation

Information required by Article 33(1) of Regulation (EC) No. 1907/2006 ("REACH") relating to products containing substances of very high concern (SVHCs) is available at [www.renishaw.com/REACH](http://www.renishaw.com/REACH).

## Disposal of waste electrical and electronic equipment



The use of this symbol on Renishaw products and/or accompanying documentation indicates that the product should not be mixed with general household waste upon disposal. It is the responsibility of the end user to dispose of this product at a designated collection point for waste electrical and electronic equipment (WEEE) to enable reuse or recycling. Correct disposal of this product will help to save valuable resources and prevent potential negative effects on the environment. For more information, contact your local waste disposal service or Renishaw distributor.

# Storage and handling

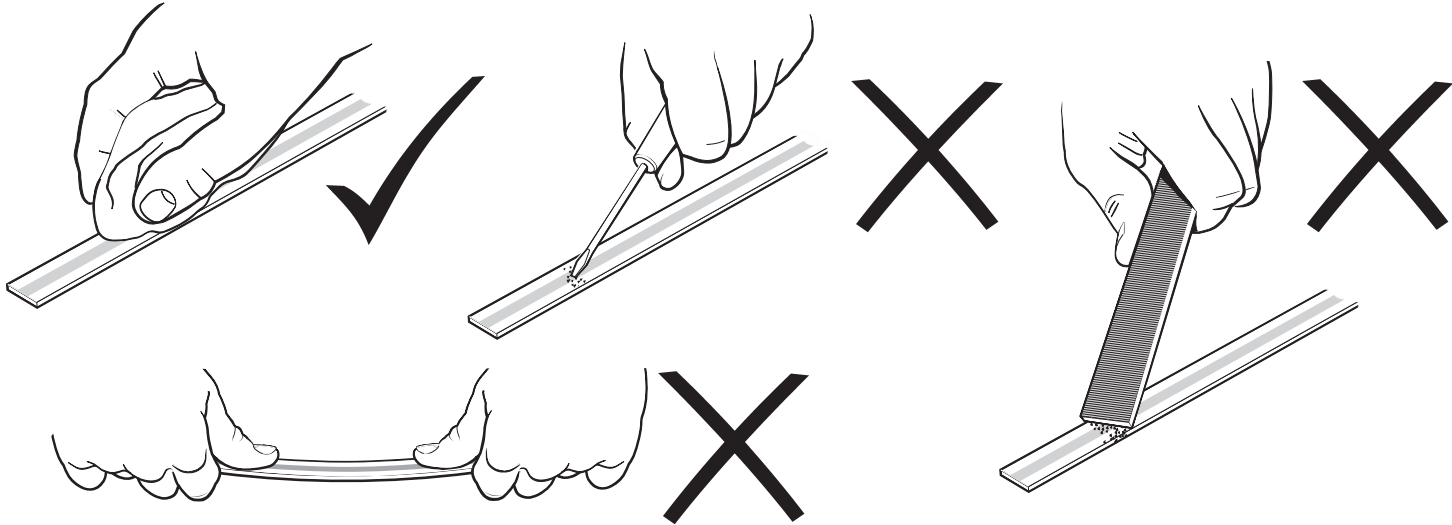



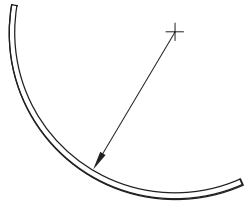

## Minimum bend radius

RELA30 - DO NOT BEND  
 RSLA30 - 250 mm

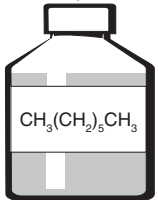
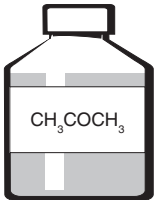
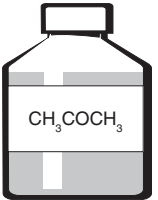
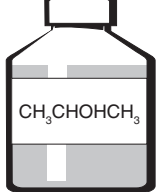
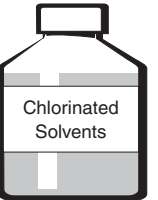
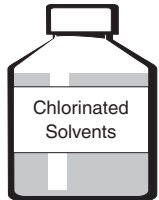

**NOTE:** Ensure self-adhesive tape is on outside of bend.

System	Scale only	Readhead and DRIVE-CLiQ interface
<p>N-heptane</p> <p><chem>CH3(CH2)5CH3</chem></p> 	<p>Acetone</p> <p><chem>CH3COCH3</chem></p> 	<p>Acetone</p> <p><chem>CH3COCH3</chem></p> 
<p>Propan-2-ol</p> <p><chem>CH3CHOHCH3</chem></p> 	<p>Chlorinated Solvents</p> 	<p>Chlorinated Solvents</p> 
		

### Readhead

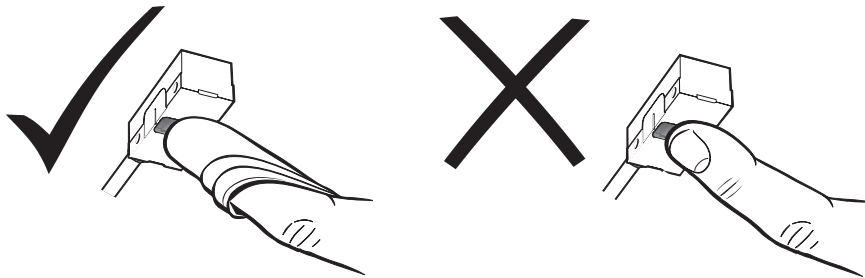

### Readhead and DRIVE-CLiQ interface

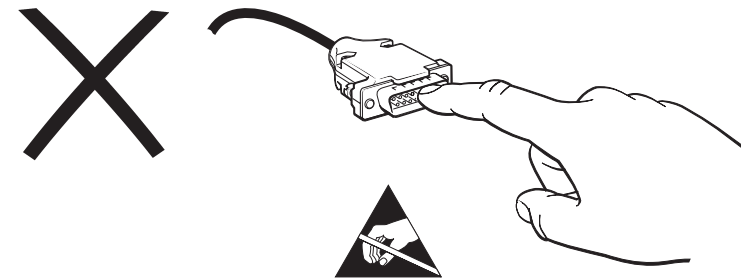

### Readhead and DRIVE-CLiQ interface



### Temperature

Storage	
Standard readhead, DRIVE-CLiQ interface, and RELA30/RSLA30 scale	-20 °C to +80 °C
UHV readhead	0 °C to +80 °C
Bakeout	+120 °C

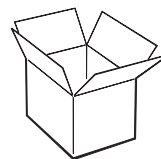

Operating	
Standard readhead and RELA30/RSLA30 scale	0 °C to +80 °C
UHV readhead	0 °C to +75 °C
DRIVE-CLiQ interface	0 °C to +55 °C

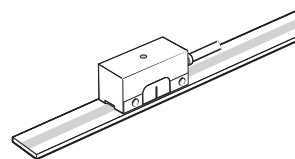

### Humidity

95% relative humidity (non-condensing) to IEC 60068-2-78

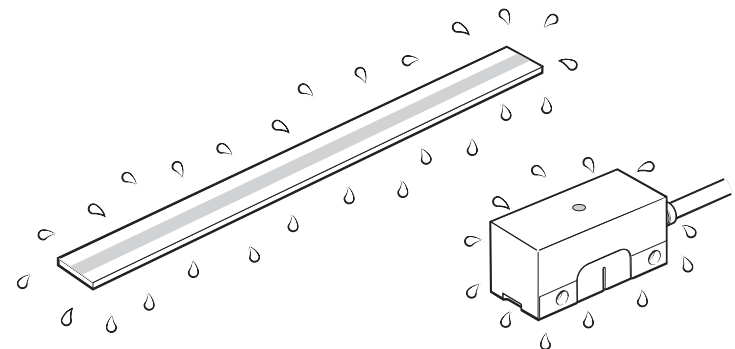

# RESOLUTE readhead installation drawing – standard cable outlet

Dimensions and tolerances in mm

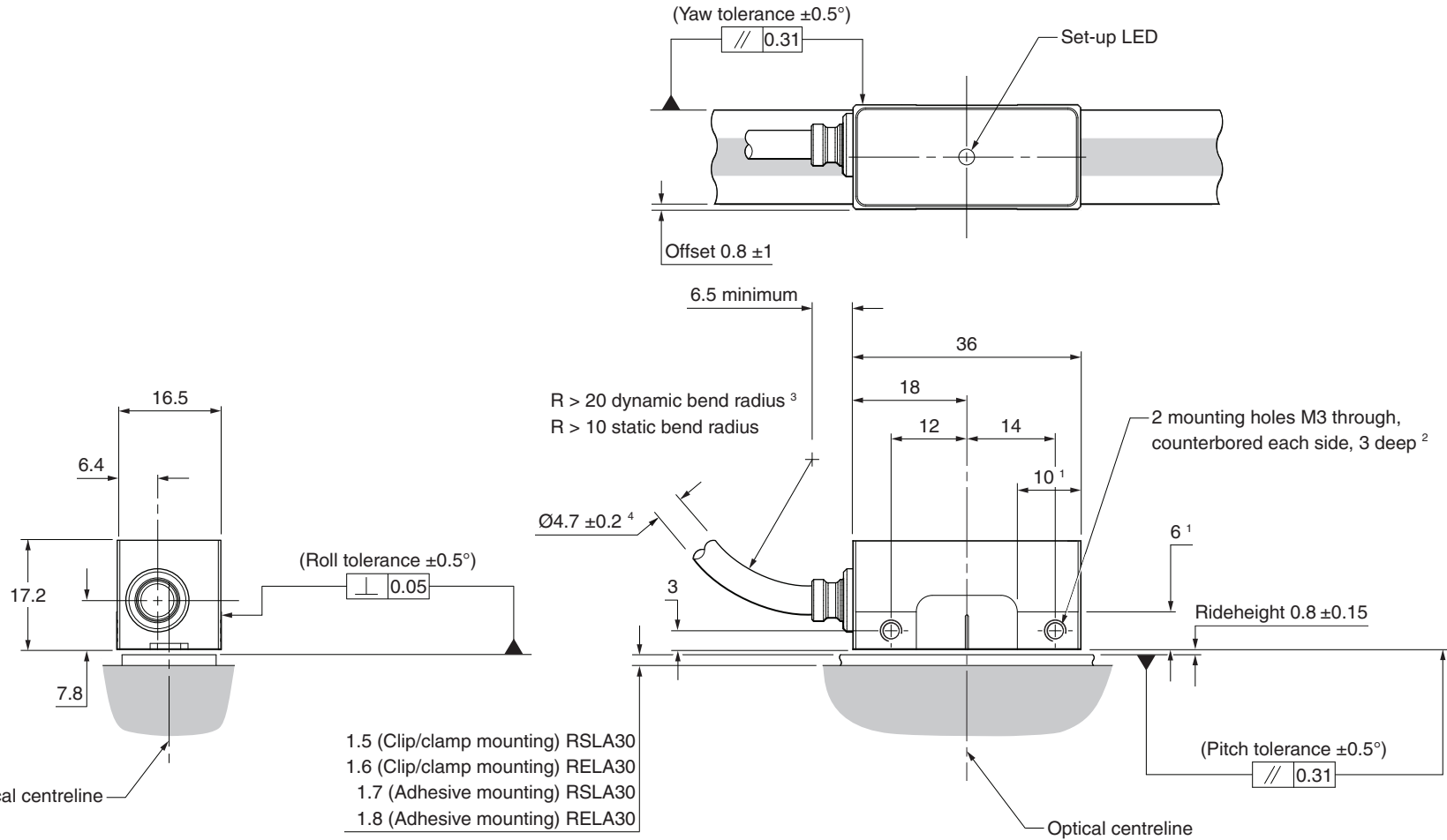

<sup>1</sup> Extent of mounting faces.

<sup>2</sup> The recommended thread engagement is 5 mm minimum (8 mm including counterbore) and the recommended tightening torque is 0.5 Nm to 0.7 Nm.

<sup>3</sup> Dynamic bend radius not applicable for UHV cables.

<sup>4</sup> UHV cable diameter 2.7 mm.

## RESOLUTE readhead installation drawing – side cable outlet

Dimensions and tolerances in mm

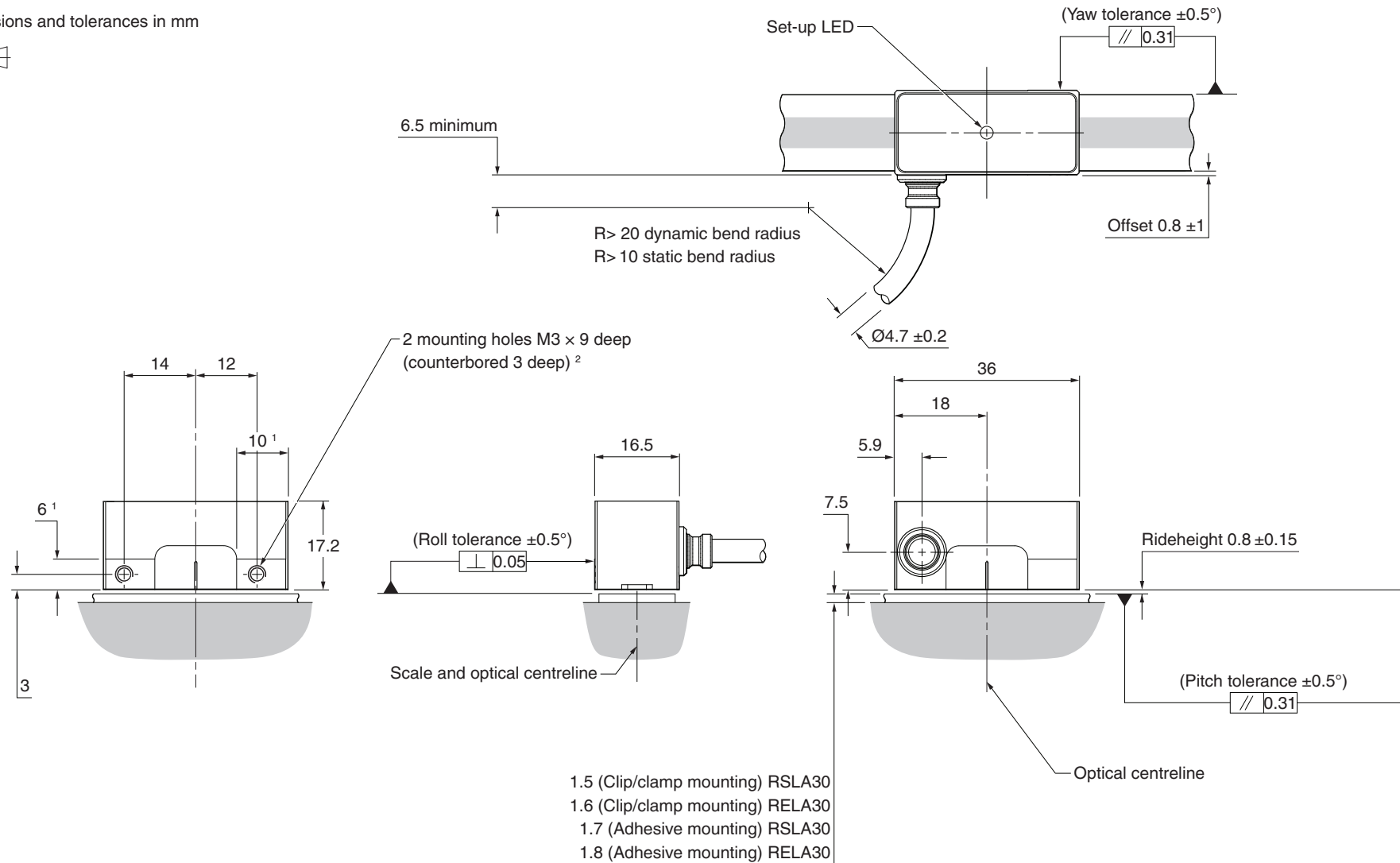

<sup>1</sup> Extent of mounting faces

<sup>2</sup> The recommended thread engagement is 5 mm minimum (8 mm including counterbore) and the recommended tightening torque is 0.5 Nm to 0.7 Nm

# RELA30/RSLA30 scale installation drawing – adhesive mounted

Dimensions and tolerances in mm

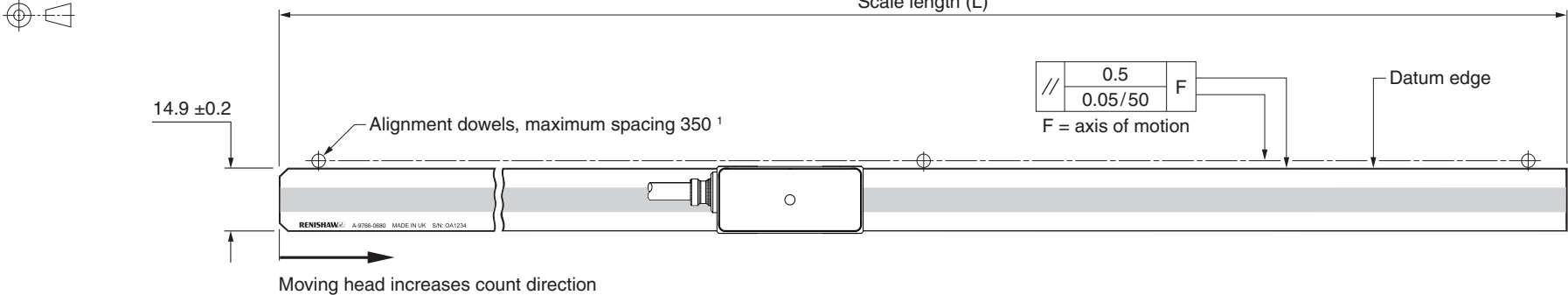

**NOTE:** The readhead can be mounted in either orientation.  
Encoder count direction is dependent only on scale orientation.

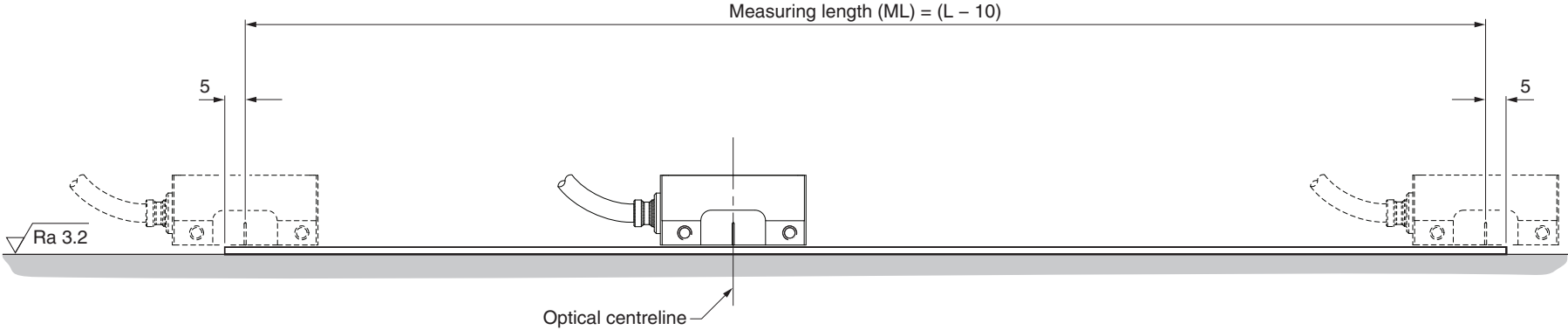

**NOTES:**

- Adhesive mounted scale should not be reused after installation.
- RELA30 shown. RSLA30 installation is the same but the scale has no chamfers.

<sup>1</sup> When the scale is to be mounted vertically, position the dowels so that the datum edge is supported.

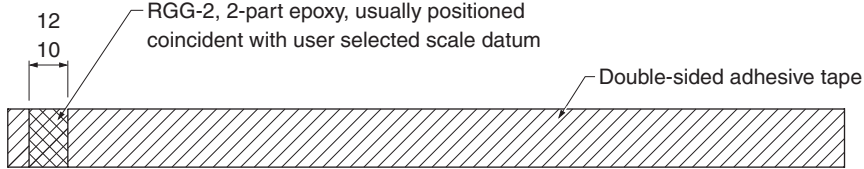

## Equipment required for adhesive mounting the RELA30/RSLA30 scale

### Required parts:

- RELA30 or RSLA30 spar scale (see '[RELA30/RSLA30 scale installation drawing – adhesive mounted](#)' on page 10)
- RGG-2 two part epoxy adhesive (A-9531-0342)
- 5 m reel of double-sided adhesive tape (A-9584-2111)
- Lint-free cloth
- Appropriate cleaning solvents (see '[Storage and handling](#)' on page 6)
- Pencil or other appropriate marker
- Scissors

### Optional parts:

- Renishaw scale wipes (A-9523-4040)
- Applicator for double-sided adhesive tape. Aids the application of the tape to the scale (A-9584-0601).

# Installing the adhesive mounted RELA30/RSLA30 scale

1. Thoroughly clean and degrease the substrate with a lint-free cloth and clean the underside of the scale using approved solvents (see 'Storage and handling' on page 6).

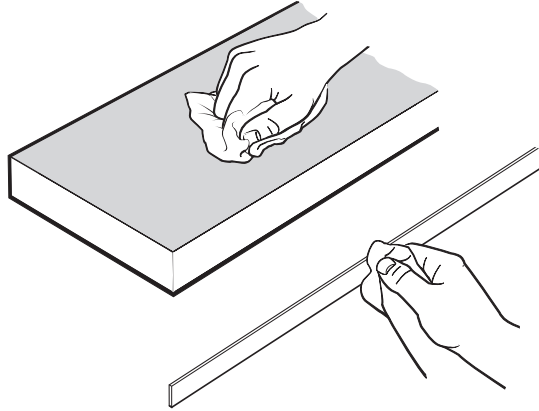

3. Remove the backing liner from one side of the adhesive tape and stick it to the underside of the scale.

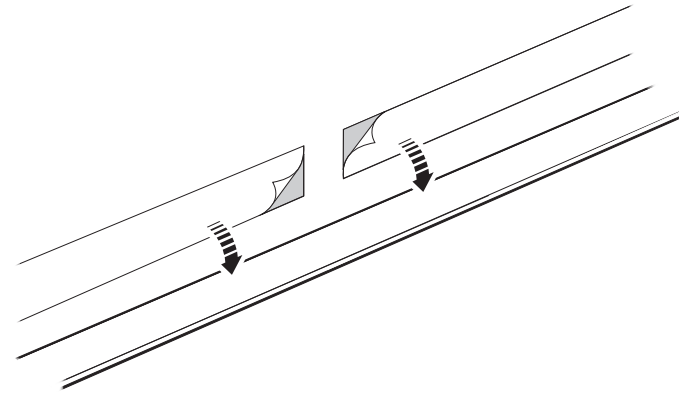

2. Mark the area for epoxy on the adhesive tape and cut the tape accordingly.

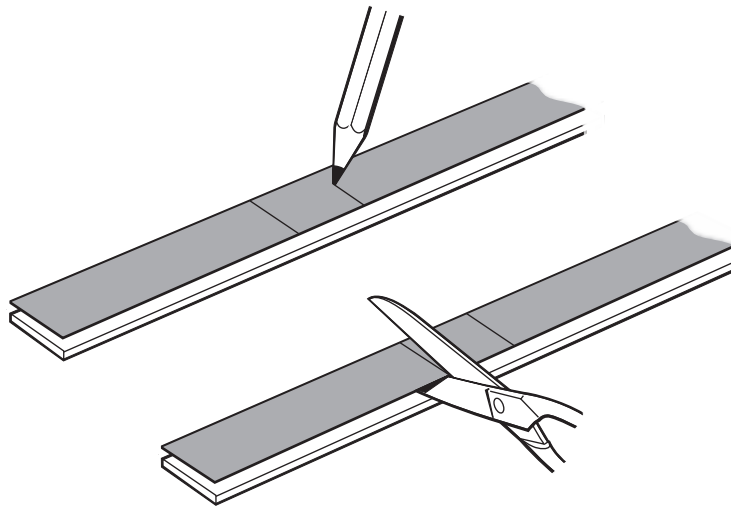

4. Thoroughly mix and apply the epoxy to the back of the scale and then remove the remaining backing liner.

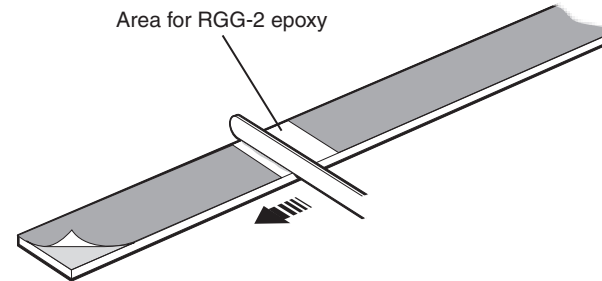

5. Locate the scale against dowels or a ledge and rotate it down onto the substrate. Press down with firm finger pressure.

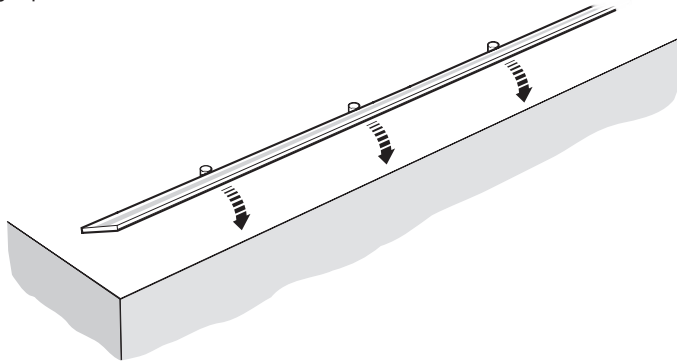

Support dowels

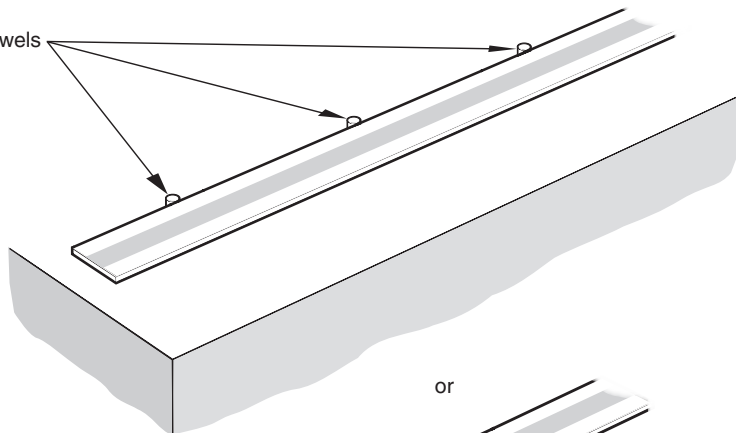

or

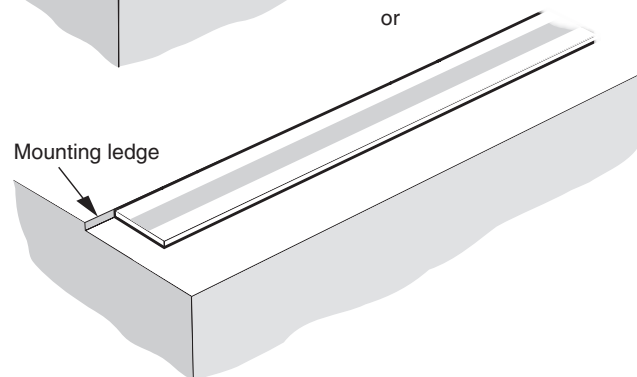

6. Remove any excess epoxy.

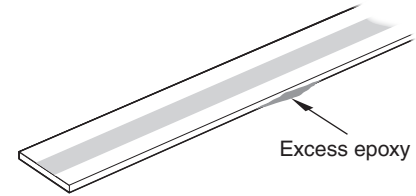

7. Allow 24 hours for the epoxy to cure fully and then clean the scale using Renishaw scale wipes or a clean, dry, lint-free cloth.

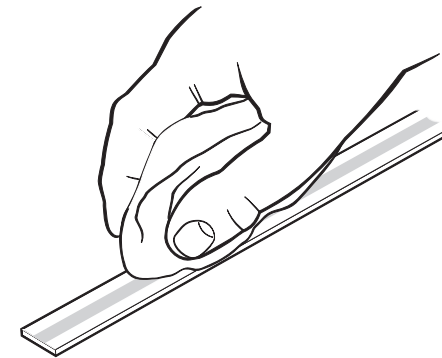

# RELA30/RSLA30 scale installation drawing – clip and clamp mounted

Dimensions and tolerances in mm

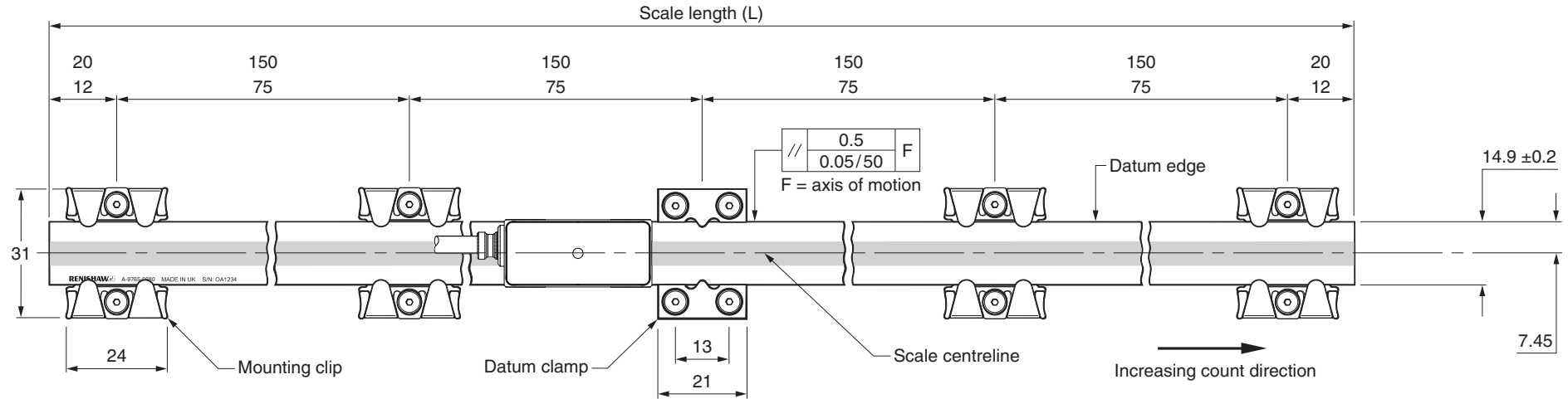

## NOTES:

- For lengths  $80 \leq L \leq 190$  ensure that the scale is clamped or clipped in the middle as well as at both ends.
  - The installation should use the least number of clips as possible.
- For lengths not specified, contact your local Renishaw representative for further advice.
- Care should be taken to ensure sufficient clearance between the readhead/mounting bracket and clips/datum clamp.
- Only special low-profile screws should be used. Screws are provided with all clips/datum clamps and spares can be supplied if required.
- Measuring length (ML) =  $(L - 10)$ .
- RSLA30 shown. RELA30 installation is the same but the scale has chamfers at one end.

## Mounting clip/Datum clamp

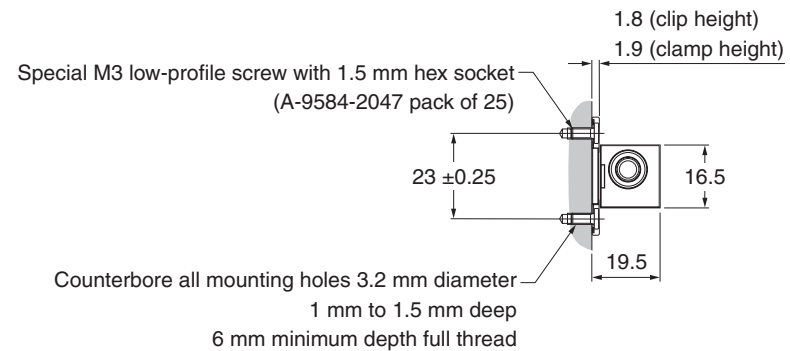

## Equipment required for clip and clamp mounting the RELA30/RSLA30 scale

### Required parts:

- RELA30 or RSLA30 spar scale (see '[RELA30/RSLA30 scale installation drawing – clip and clamp mounted](#)' on page 14)
- Clip set (A-9584-2049) containing a pair of clips with screws
- Clamp set (A-9584-2050) containing:
  - Pair of clamps with screws
  - Clip setting shim (M-9584-0928)
  - 1.5 mm hex key
- Lint-free cloth
- Appropriate cleaning solvents (see '[Storage and handling](#)' on page 6)
- Dial Test Indicator (DTI)

### Optional parts:

- Renishaw scale wipes (A-9523-4040)
- Temporary bridge clamps (A-9584-2112)
- Pack of 25 additional low profile screws (A-9584-2047)

## Installing the clip and clamp mounted RELA30/RSLA30 scale

1. Thoroughly clean and degrease the substrate with a lint-free cloth and clean the underside of the scale using approved solvents (see 'Storage and handling' on page 6).

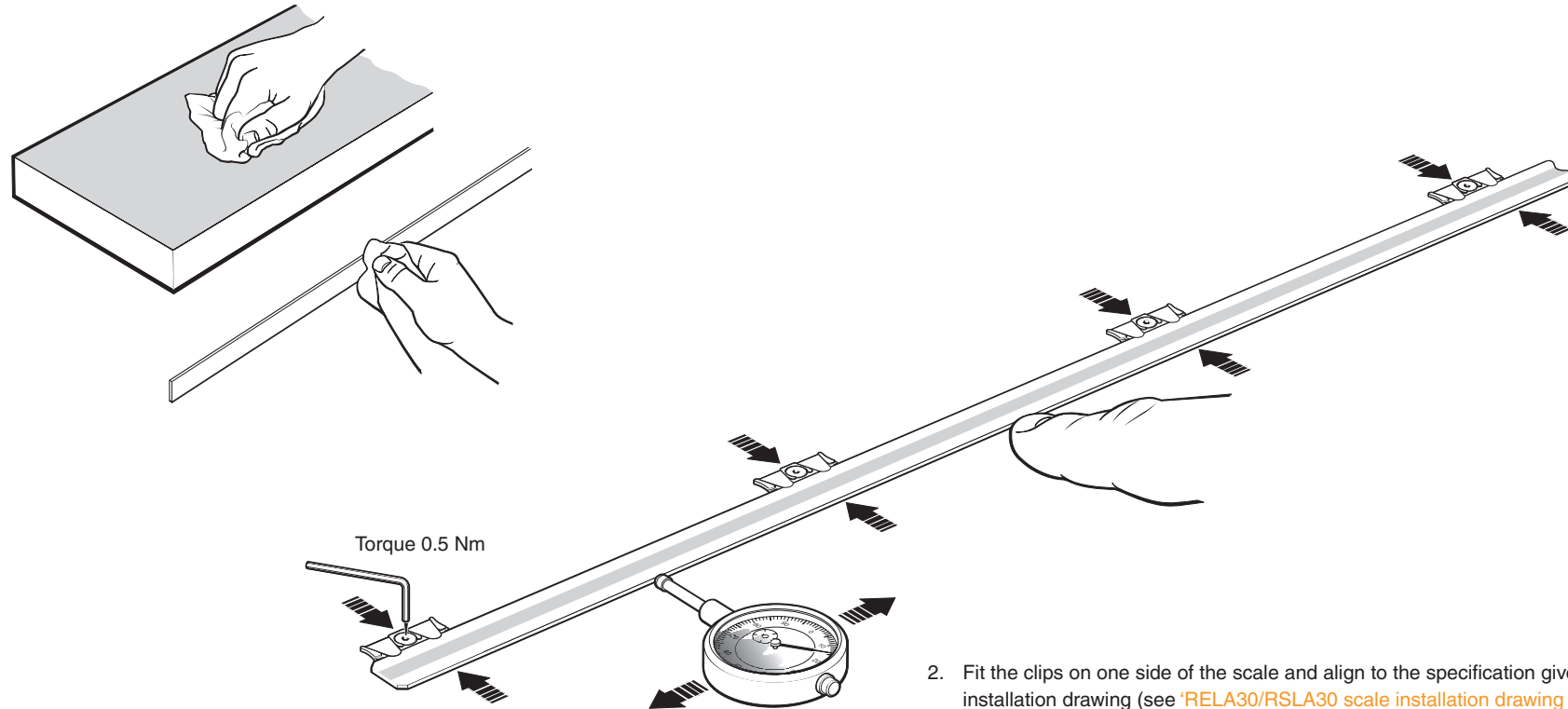

2. Fit the clips on one side of the scale and align to the specification given in the installation drawing (see 'RELA30/RSLA30 scale installation drawing – clip and clamp mounted' on page 14).

---

### NOTES:

- Only the special low-profile screws supplied with the clips should be used.
  - Additional screws can be purchased from Renishaw.
  - When mounting the scale to vertical surfaces, temporary bridge clamps are available which support the scale prior to fitting clips.
-

3. Fit the remaining clips using the clip setting shim (provided with the clamp set).

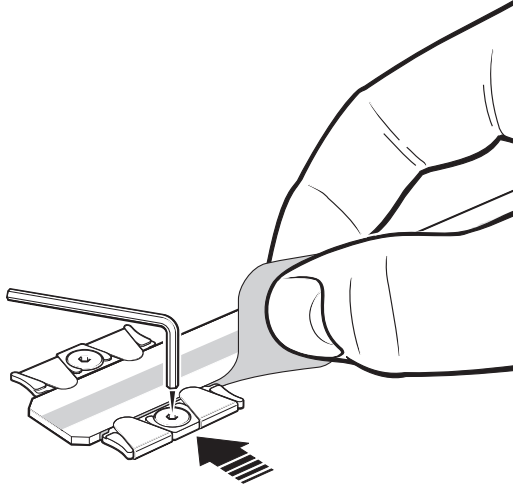

4. Place the datum clamps against the scale and secure using the special M3 low-profile screws supplied.

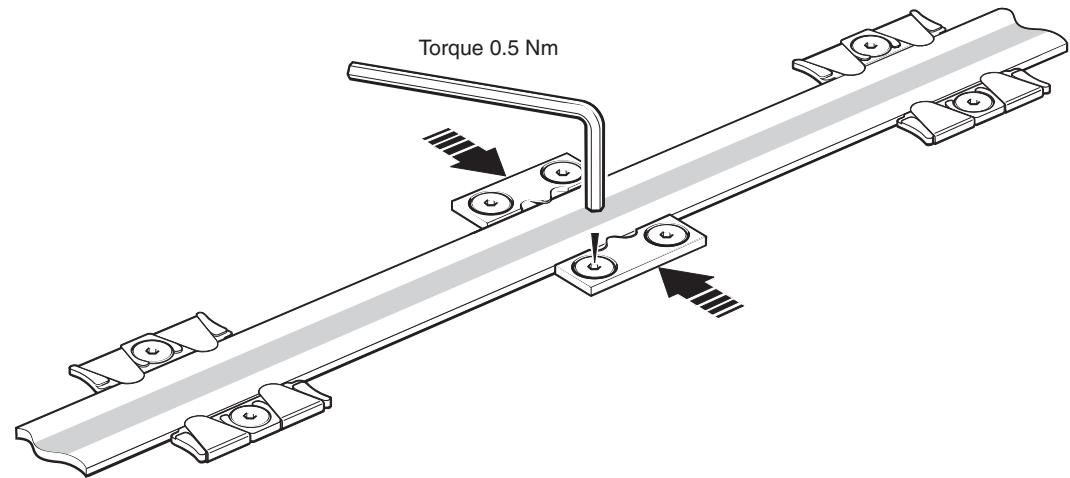

5. Clean the scale using Renishaw scale wipes or a clean, dry, lint-free cloth.

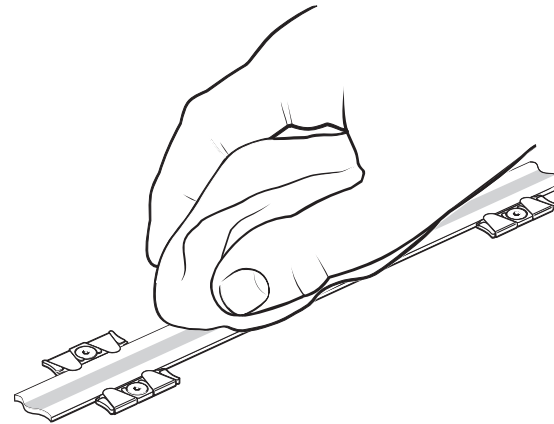

# RESOLUTE readhead mounting and alignment

## Mounting brackets

The bracket must have a flat mounting surface and should provide adjustment to enable conformance to the installation tolerances, allow adjustment to the rideheight of the readhead, and be sufficiently stiff to prevent deflection or vibration of the readhead during operation.

## Readhead set-up

Ensure that the scale, readhead optical window and mounting face are clean and free from obstructions.

**NOTE:** When cleaning the readhead and scale apply cleaning fluid sparingly, do not soak.

To set nominal rideheight, place the blue spacer with the aperture under the optical centre of the readhead to allow normal LED function during set-up procedure. Adjust the readhead to maximize the signal strength along the full axis of travel to achieve a green or blue LED.

### NOTES:

- Flashing of the set-up LED indicates scale reading error. The flashing state is latched for some serial protocols; remove power to reset.
- The optional Advanced Diagnostic Tool ADTa-100<sup>1</sup> (A-6525-0100) and ADT View software<sup>2</sup> can be used to aid installation. The ADTa-100 and ADT View software are only compatible with RESOLUTE readheads showing the **ADT** mark. Contact your local Renishaw representative for other readhead compatibility.

<sup>1</sup> For more details refer to the Advanced Diagnostic Tools and ADT View software User guide (Renishaw part no. M-6195-9413).

<sup>2</sup> The software can be downloaded for free from [www.renishaw.com/adt](http://www.renishaw.com/adt).

<sup>3</sup> The LED is activated regardless of whether the corresponding messages have been reconfigured.

<sup>4</sup> The colour depends upon the LED status when component recognition is activated via p0144=1.

<sup>5</sup> RESOLUTE Siemens DRIVE-CLiQ readheads require the Siemens DRIVE-CLiQ interface to function correctly.

## RESOLUTE readhead and DRIVE-CLiQ interface status LEDs

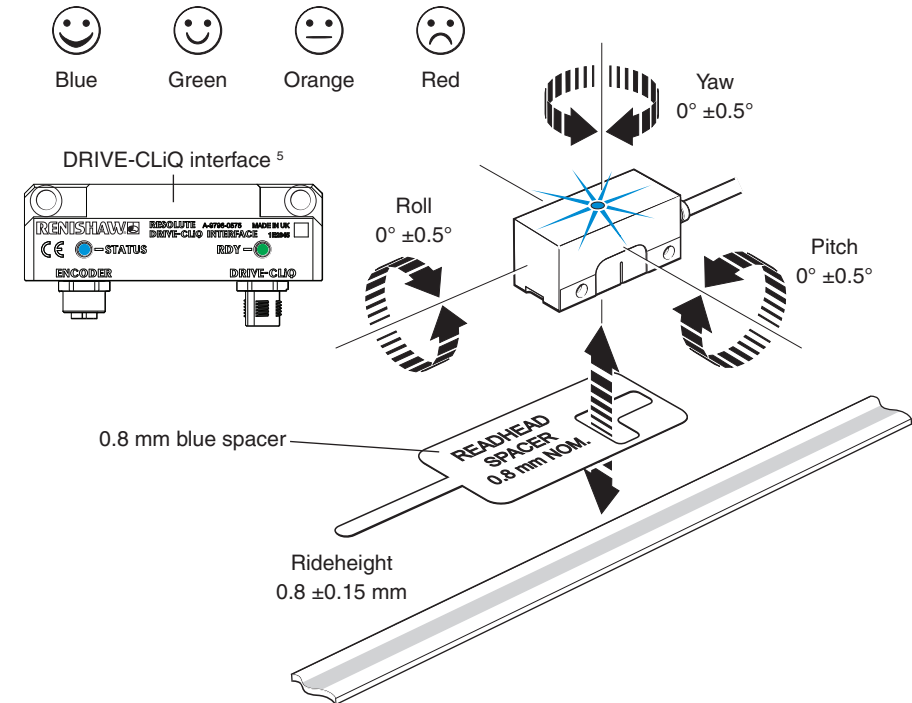

## DRIVE-CLiQ interface RDY LED functions

Colour	Status	Description
-	Off	Power supply is missing or outside of permissible tolerance range
Green	Continuous light	The component is ready for operation and cyclic DRIVE-CLiQ communication is taking place
Orange	Continuous light	DRIVE-CLiQ communication is being established
Red	Continuous light	At least one fault is present in this component <sup>3</sup>
Green/orange or red/orange	Flashing light	Component recognition via LED is activated (p0144) <sup>4</sup>

## RESOLUTE readhead signals

### BiSS C serial interface

Function	Signal <sup>1</sup>	Wire colour	Pin				
			9-way D-type (A)	LEMO (L)	M12 (S)	13-way JST (F and V)	
Power	5 V	Brown	4, 5	11	2	9	
	0 V	White	8, 9	8, 12	5, 8	5, 7	
		Green					
Serial communications	MA+	Violet	2	2	3	11	
	MA-	Yellow	3	1	4	13	
	SLO+	Grey	6	3	7	1	
	SLO-	Pink	7	4	6	3	
Shield	Single	Shield	Shield	Case	Case	Case	External
	Double	Inner	Inner shield	1	10	1	External
		Outer	Outer shield	Case	Case	Case	External

<sup>1</sup> For details, refer to *BiSS C-mode (unidirectional) for RESOLUTE encoders* data sheet (Renishaw part no. L-9709-9005).

**NOTE:** For RESOLUTE BiSS UHV readheads only 13-way JST (V) option is available.

### FANUC serial interface

Function	Signal	Wire colour	Pin					
			9-way D-type (A)	LEMO (L)	20-way (H)	M12 (S)	13-way JST (F)	
Power	5 V	Brown	4, 5	11	9, 20	2	9	
	0 V	White	8, 9	8, 12	12, 14	5, 8	5, 7	
		Green						
Serial communications	REQ	Violet	2	2	5	3	11	
	*REQ	Yellow	3	1	6	4	13	
	SD	Grey	6	3	1	7	1	
	*SD	Pink	7	4	2	6	3	
Shield	Single	Shield	Shield	Case	Case	External, 16	Case	External
	Double	Inner	Inner shield	1	10	16	1	External
		Outer	Outer shield	Case	Case	External	Case	External

## Mitsubishi serial interface

Function	Signal	Wire colour	Pin						
			9-way D-type (A)	10-way Mitsubishi (P)	15-way D-type (N)	LEMO (L)	M12 (S)	13-way JST (F)	
Power	5 V	Brown	4, 5	1	7, 8	11	2	9	
	0 V	White	8, 9	2	2, 9	8, 12	5, 8	5, 7	
		Green							
Serial communications	MR	Violet	2	3	10	2	3	11	
	MRR	Yellow	3	4	1	1	4	13	
	MD <sup>1</sup>	Grey	6	7	11	3	7	1	
	MDR <sup>1</sup>	Pink	7	8	3	4	6	3	
Shield	Single	Shield	Shield	Case	Case	Case	Case	Case	External
	Double	Inner	Inner shield	1	Not applicable	15	10	1	External
		Outer	Outer shield	Case		Case	Case	Case	External

<sup>1</sup> For 2 wire RESOLUTE Mitsubishi readheads do not connect MD and MDR.

## Panasonic/Omron serial interface

Function	Signal	Wire colour	Pin				
			9-way D-type (A)	LEMO (L)	M12 (S)	13-way JST (F and V)	
Power	5 V	Brown	4, 5	11	2	9	
	0 V	White	8, 9	8, 12	5, 8	5, 7	
		Green					
Serial communications	PS	Violet	2	2	3	11	
	$\overline{PS}$	Yellow	3	1	4	13	
Shield	Single	Shield	Shield	Case	Case	Case	External
	Double	Inner	Inner shield	1	10	1	External
		Outer	Outer shield	Case	Case	Case	External
Reserved	Do not connect	Grey	6	3	7	1	
		Pink	7	4	6	3	

**NOTE:** For RESOLUTE Panasonic UHV readheads only 13-way JST (V) option is available.

## Siemens DRIVE-CLiQ serial interface

### DRIVE-CLiQ readhead output

Function	Signal	Wire colour	Pin		
			M12 (S)	13-way JST (F and V)	
Power	5 V	Brown	2	9	
	0 V	White	5, 8	5, 7	
		Green			
Serial communications	A+	Violet	3	11	
	A-	Yellow	4	13	
Shield	Single	Shield	Case	External	
	Double	Inner	Inner shield	1	External
		Outer	Outer shield	Case	External
Reserved	Do not connect	Grey	7	1	
		Pink	6	3	

### DRIVE-CLiQ interface output

Function	Signal	Pin M12
Power	24 V	1
	0 V	5
DRIVE-CLiQ communications	RX+	3
	RX-	4
	TX+	7
	TX-	6
Shield	Shield	Case

**NOTE:** For RESOLUTE Siemens DRIVE-CLiQ UHV readheads only 13-way JST (V) option is available.

## Yaskawa serial interface

Function	Signal	Wire colour	Pin			
			9-way D-type (A)	LEMO (L)	M12 (S)	13-way JST (F)
Power	5 V	Brown	4, 5	11	2	9
	0 V	White	8, 9	8, 12	5, 8	5, 7
		Green				
Serial communications	S	Violet	2	2	3	11
	$\bar{S}$	Yellow	3	1	4	13
Shield	Shield	Shield	Case	Case	Case	External
Reserved	Do not connect	Grey	6	3	7	1
		Pink	7	4	6	3

# RESOLUTE readhead termination options

## 9-way D-type connector (Termination code A)

Plugs directly into the optional Advanced Diagnostic Tool ADTa-100<sup>1</sup>  
 (ADT compatible readheads only)

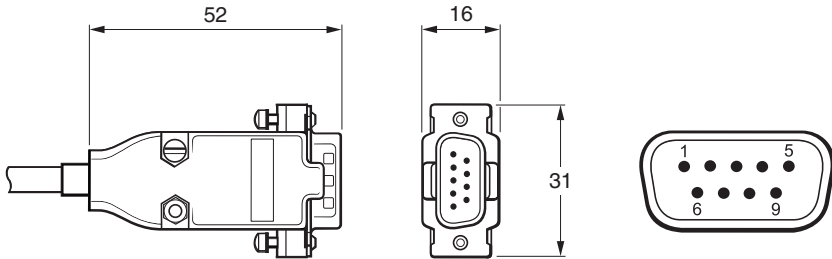

## M12 (sealed) connector (Termination code S)

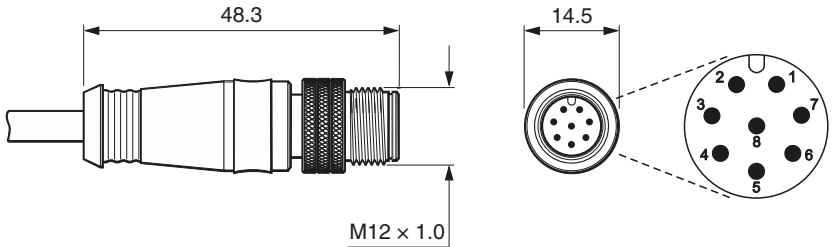

## LEMO in-line connector (Termination code L)

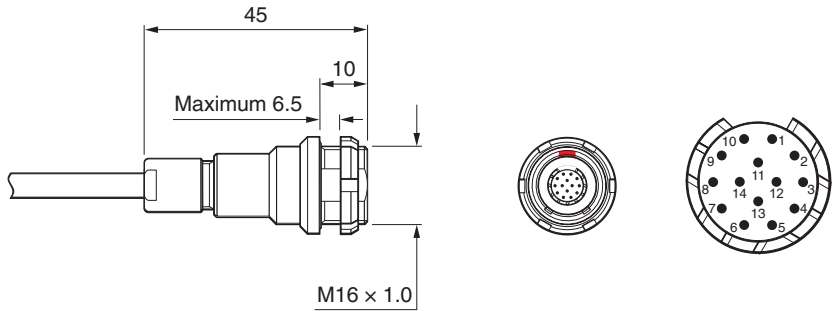

## 13-way flying lead<sup>2</sup> (Termination code F and V) (single-shielded cable shown)

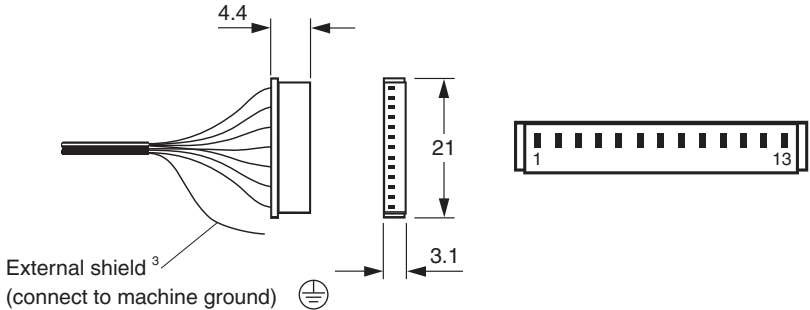

<sup>1</sup> For more details refer to the *Advanced Diagnostic Tools and ADT View software User guide* (Renishaw part no. M-6195-9413).  
<sup>2</sup> JST part number: 13ZR-3H-P.  
<sup>3</sup> External shield not present on termination code V.

**15-way D-type Mitsubishi connector  
 (Termination code N)**

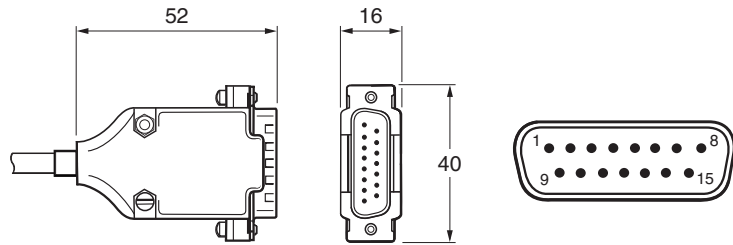

**20-way FANUC connector (Termination code H)**

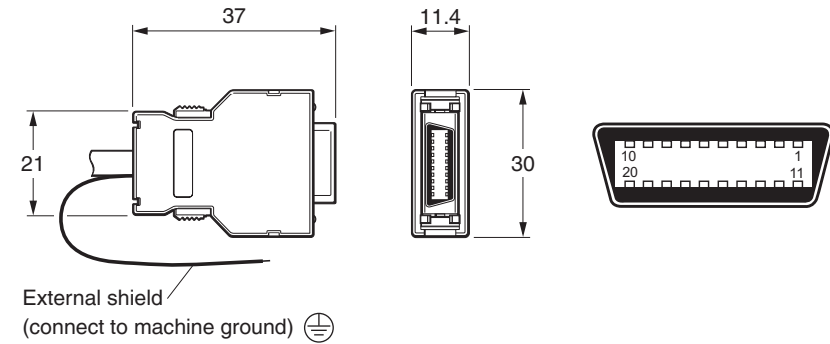

**10-way Mitsubishi connector (Termination code P)**

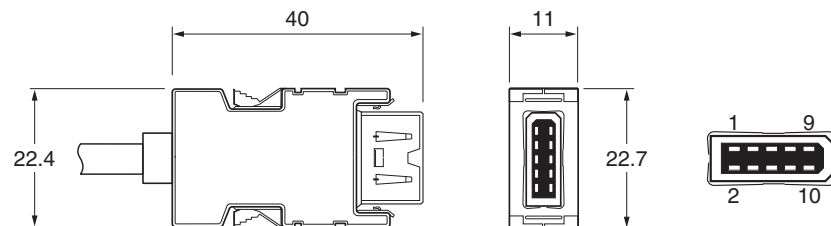

# Siemens DRIVE-CLiQ interface drawing – single readhead input

Dimensions and tolerances in mm

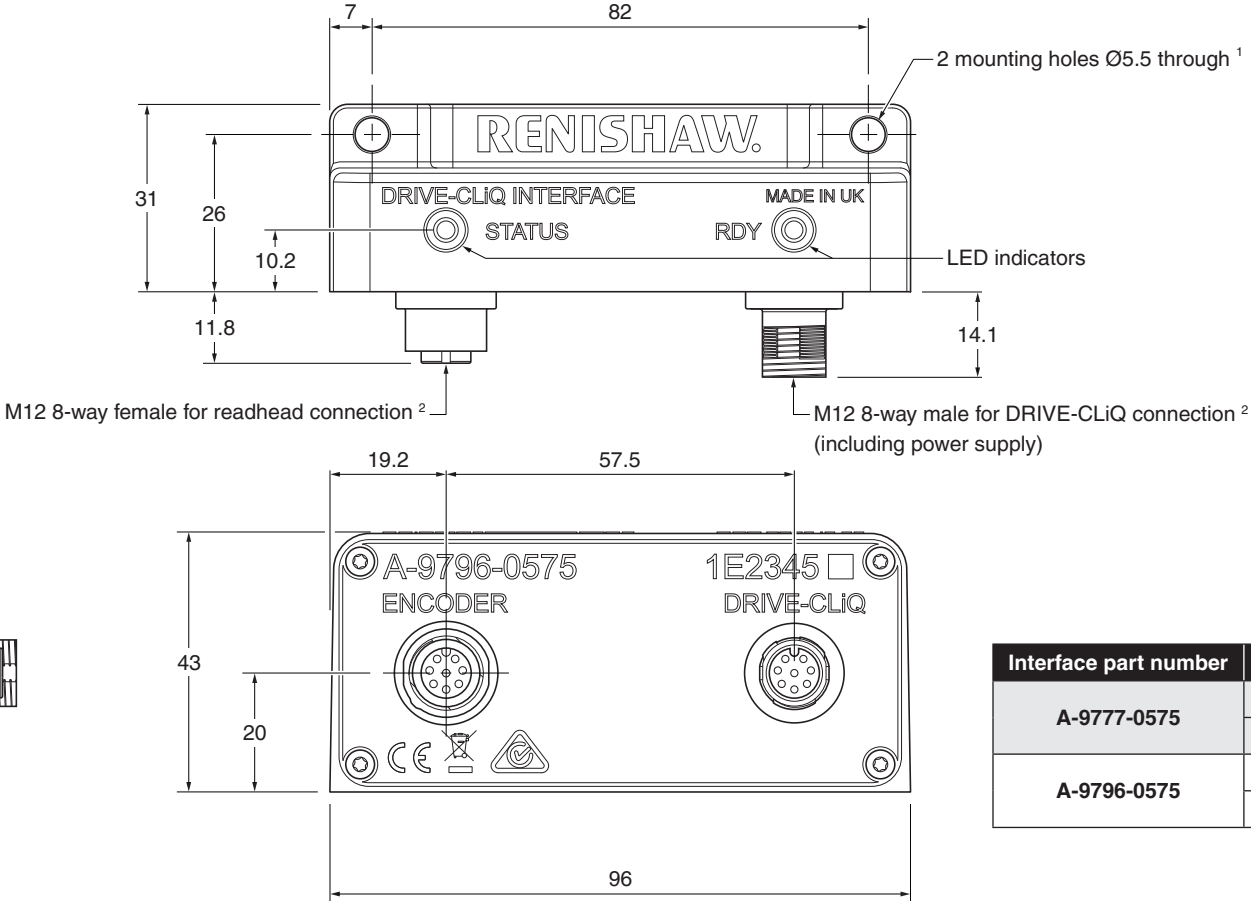

Interface part number	Compatible readheads
A-9777-0575	RLxxDA
	RLxxDS
A-9796-0575	RLxxDB
	RLxxDR

**NOTE:** RESOLUTE Siemens DRIVE-CLiQ readheads require the Siemens DRIVE-CLiQ interface to function correctly.

<sup>1</sup> Screw grade: ISO 4762-M5. Maximum tightening torque 4 Nm. Recommended thread engagement ≥ 5 mm.

<sup>2</sup> Maximum tightening torque 4 Nm.

## Electrical connections

### Grounding and shielding <sup>1</sup>

#### Single-shielded cable <sup>2</sup>

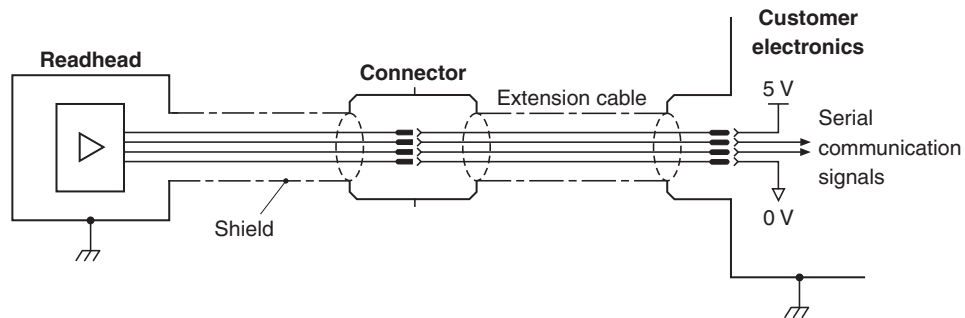

#### IMPORTANT:

- The shield should be connected to the machine earth (Field ground).
- If the connector is modified or replaced, the customer must ensure both 0 V cores (white and green) are connected to 0 V.

#### Double-shielded cable <sup>2</sup>

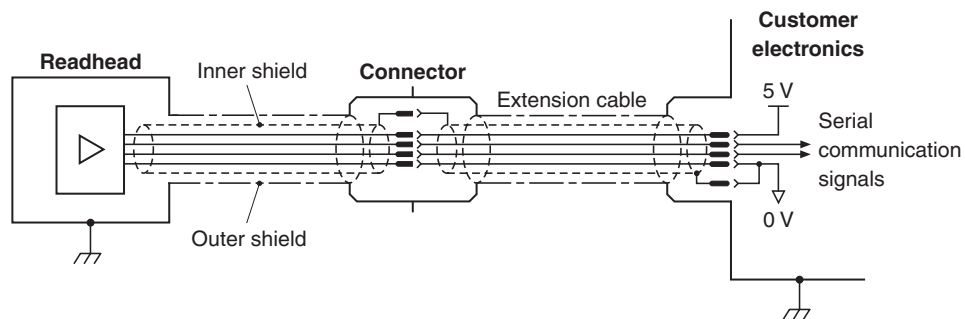

#### IMPORTANT:

- The outer shield should be connected to the machine earth (Field ground). The inner shield should be connected to 0 V at customer electronics only. Care should be taken to ensure that the inner and outer shields are insulated from each other.
- If the connector is modified or replaced, the customer must ensure both 0 V cores (white and green) are connected to 0 V.

<sup>1</sup> RESOLUTE BiSS, FANUC, Mitsubishi, Panasonic/Omron, and Yaskawa readheads only. For RESOLUTE Siemens DRIVE-CLiQ systems, refer to page 26 for grounding and shielding arrangements.

<sup>2</sup> RESOLUTE Yaskawa readheads are single-shielded cable only

# Grounding and shielding - RESOLUTE Siemens DRIVE-CLiQ systems only

## Single-shielded cable

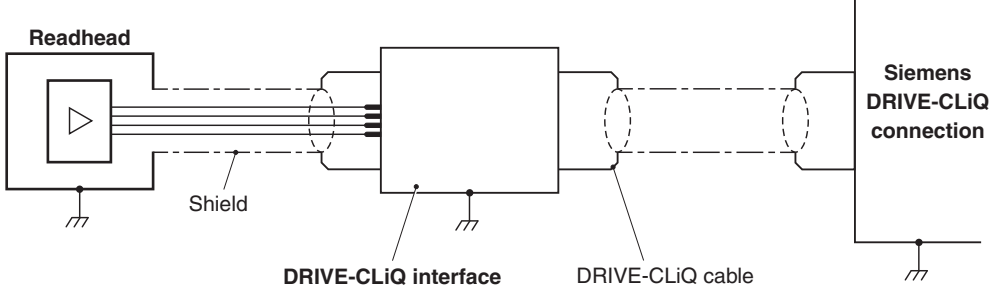

## Double-shielded cable

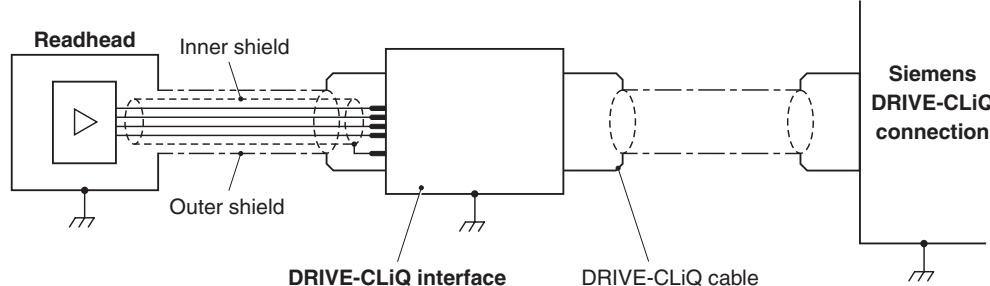

**IMPORTANT:** If reterminating double-shielded readhead cable, care should be taken to ensure that the inner and outer shields are insulated from each other. If the inner and outer shields are connected together, this will cause a short between 0 V and earth, which could cause electrical noise issues.

## General specifications

<b>Power supply</b> <sup>1</sup>		5 V ±10%	1.25 W maximum (250 mA @ 5 V)
	(DRIVE-CLiQ system) <sup>2</sup>	24 V	3.05 W maximum (encoder: 1.25 W + interface: 1.8 W). 24 V power is provided by the DRIVE-CLiQ network.
		Ripple	200 mVpp maximum @ frequency up to 500 kHz
<b>Sealing</b>	(readhead - standard)		IP64
	(readhead - UHV)		IP30
	(DRIVE-CLiQ interface)		IP67
<b>Acceleration</b>	(readhead)	Operating	500 m/s <sup>2</sup> , 3 axes
<b>Shock</b>	(readhead and interface)	Non-operating	1000 m/s <sup>2</sup> , 6 ms, ½ sine, 3 axes
<b>Maximum acceleration of scale with respect to readhead</b> <sup>3</sup>			2000 m/s <sup>2</sup>
<b>Vibration</b>	(readhead - standard)	Operating	Sinusoidal 300 m/s <sup>2</sup> , 55 Hz to 2000 Hz, 3 axes
	(readhead - UHV)	Operating	Sinusoidal 100 m/s <sup>2</sup> , 55 Hz to 2000 Hz, 3 axes
	(DRIVE-CLiQ interface)	Operating	Sinusoidal 100 m/s <sup>2</sup> , 55 Hz to 2000 Hz, 3 axes
<b>Mass</b>	(readhead - standard)		18 g
	(readhead - UHV)		19 g
	(cable - standard)		32 g/m
	(cable - UHV)		19 g/m
	(DRIVE-CLiQ interface)		218 g
<b>Readhead cable</b>	(standard)		7 core, tinned and annealed copper, 28 AWG Outside diameter 4.7 ±0.2 mm Single-shielded: Flex life > 40 × 10 <sup>6</sup> cycles at 20 mm bend radius Double-shielded: Flex life > 20 × 10 <sup>6</sup> cycles at 20 mm bend radius UL recognised component  Silver-coated copper braided single screen FEP core insulation over tin-plated copper wire.
	(UHV)		
<b>Maximum readhead cable length</b>			10 m (to controller or DRIVE-CLiQ interface) (Refer to Siemens DRIVE-CLiQ specifications for maximum cable length from DRIVE-CLiQ interface to controller)

**CAUTION:** The RESOLUTE encoder system has been designed to the relevant EMC standards, but must be correctly integrated to achieve EMC compliance. In particular, attention to shielding arrangements is essential.

<sup>1</sup> Current consumption figures refer to terminated RESOLUTE systems. Renishaw encoder systems must be powered from a 5 Vdc supply complying with the requirements for SELV of standard IEC 60950-1.

<sup>2</sup> The Renishaw DRIVE-CLiQ interface must be powered from a 24 Vdc supply complying with the requirements for SELV of standard IEC 60950-1.

<sup>3</sup> This is the worst case figure that is correct for the slowest communications clock rates. For faster clock rates, the maximum acceleration of scale with respect to the readhead can be higher. For more details, contact your local Renishaw representative.

## RELA30 spar scale specifications

<b>Form (height × width)</b>	1.6 mm × 14.9 mm
<b>Pitch</b>	30 µm
<b>Accuracy (at 20 °C)</b>	Certified to ±1 µm for lengths up to 1 m ±1 µm/m for lengths > 1 m to 1.7 m Calibration traceable to International Standards
<b>Material</b>	ZeroMet™ high stability low-expansion nickel-iron alloy
<b>Mass</b>	184 g/m
<b>Coefficient of thermal expansion (at 20 °C)</b>	0.75 ±0.35 µm/m/°C
<b>Mounting</b>	Epoxy datum point and adhesive tape (nominal thickness 0.2 mm) or mechanical datum clamp and mounting clips

## Maximum length

The maximum scale length is determined by the readhead resolution and the number of position bits in the serial word. For RESOLUTE readheads with fine resolution and short word length, the maximum scale length will be limited accordingly. Conversely, coarser resolutions or longer word lengths enable the use of longer scale lengths.

Serial protocol	Protocol word length	Maximum scale length (m)			
		Resolution			
		1 nm	5 nm	50 nm	100 nm
BiSS	26 Bit	0.067	0.336	3.355	-
	32 Bit	1.7	1.7	1.7	-
	36 Bit	1.7	1.7	1.7	-
FANUC	37 Bit	1.7	-	1.7	-
Mitsubishi	40 Bit	1.7	-	1.7	-
Panasonic	48 Bit	1.7	-	1.7	1.7
Siemens DRIVE-CLiQ	28 Bit	-	-	1.7	-
	34 Bit	1.7	-	-	-
Yaskawa	36 Bit	1.7	-	1.7	-

## RSLA30 spar scale specifications

<b>Form (height × width)</b>	1.5 mm × 14.9 mm
<b>Pitch</b>	30 µm
<b>Accuracy (at 20 °C)</b>	±1.5 µm/m for lengths up to 1 m ±2.25 µm/m for lengths from 1 m to 2 m ±3 µm/m for lengths from 2 m to 3 m ±4 µm/m for lengths from 3 m to 5 m (includes slope and linearity) Calibration traceable to International Standards
<b>Material</b>	Hardened martensitic stainless steel
<b>Mass</b>	172 g/m
<b>Coefficient of thermal expansion (at 20 °C)</b>	10.1 ±0.2 µm/m/°C
<b>Mounting</b>	Epoxy datum point and adhesive tape (nominal thickness 0.2 mm) or mechanical datum clamp and mounting clips



## Maximum length

The maximum scale length is determined by the readhead resolution and the number of position bits in the serial word. For RESOLUTE readheads with fine resolution and short word length, the maximum scale length will be limited accordingly. Conversely, coarser resolutions or longer word lengths enable the use of longer scale lengths.

Serial protocol	Protocol word length	Maximum scale length (m)			
		Resolution			
		1 nm	5 nm	50 nm	100 nm
BiSS	26 Bit	0.067	0.336	3.355	-
	32 Bit	4.295	5	5	-
	36 Bit	5	5	5	-
FANUC	37 Bit	5	-	5	-
Mitsubishi	40 Bit	2.1	-	5	-
Panasonic	48 Bit	5	-	5	5
Siemens DRIVE-CLiQ	28 Bit	-	-	5	-
	34 Bit	5	-	-	-
Yaskawa	36 Bit	1.8	-	5	-

[www.renishaw.com/contact](http://www.renishaw.com/contact)

 #renishaw

 **+44 (0) 1453 524524**     **uk@renishaw.com**

© 2009–2026 Renishaw plc. All rights reserved. This document may not be copied or reproduced in whole or in part, or transferred to any other media or language by any means, without the prior written permission of Renishaw.  
RENISHAW® and the probe symbol are registered trade marks of Renishaw plc. Renishaw product names, designations and the mark 'apply innovation' are trade marks of Renishaw plc or its subsidiaries. Other brand, product or company names are trade marks of their respective owners. Renishaw plc. Registered in England and Wales. Company no: 1106260. Registered office: New Mills, Wotton-under-Edge, Glos, GL12 8JR, UK.

WHILE CONSIDERABLE EFFORT WAS MADE TO VERIFY THE ACCURACY OF THIS DOCUMENT AT PUBLICATION, ALL WARRANTIES, CONDITIONS, REPRESENTATIONS AND LIABILITY, HOWSOEVER ARISING, ARE EXCLUDED TO THE EXTENT PERMITTED BY LAW. RENISHAW RESERVES THE RIGHT TO MAKE CHANGES TO THIS DOCUMENT AND TO THE EQUIPMENT, AND/OR SOFTWARE AND THE SPECIFICATION DESCRIBED HEREIN WITHOUT OBLIGATION TO PROVIDE NOTICE OF SUCH CHANGES.

Part no.: M-9553-9128-07-C  
Issued: 04.2026