

# Equator-X interlock

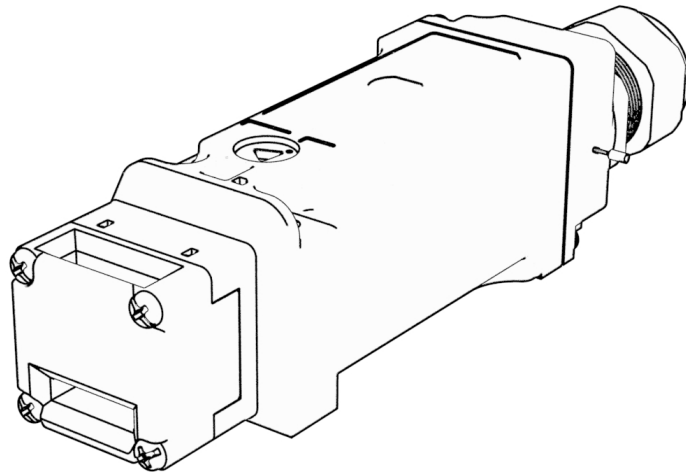

## Kit contents

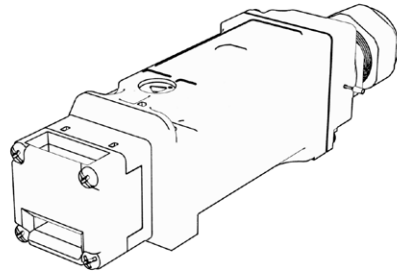

**Interlock assembly x1**

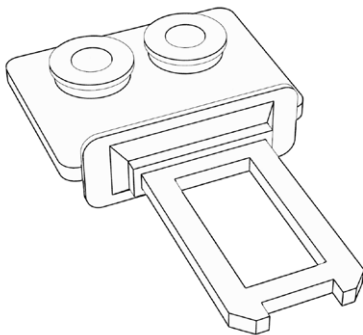

**Interlock tang x1**



**M4x45 mm x3**



**M4x12 mm x2**

1. Remove bolts

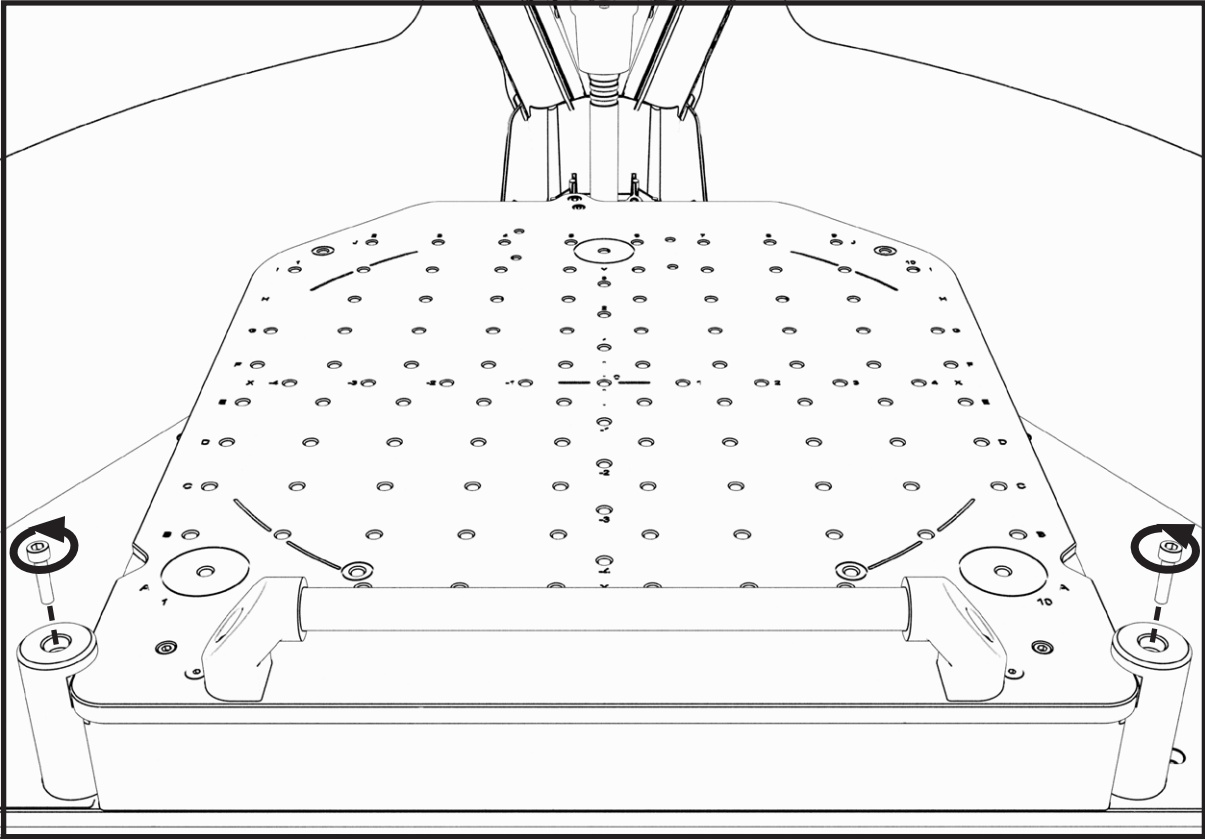

2. Remove Tile Restraints

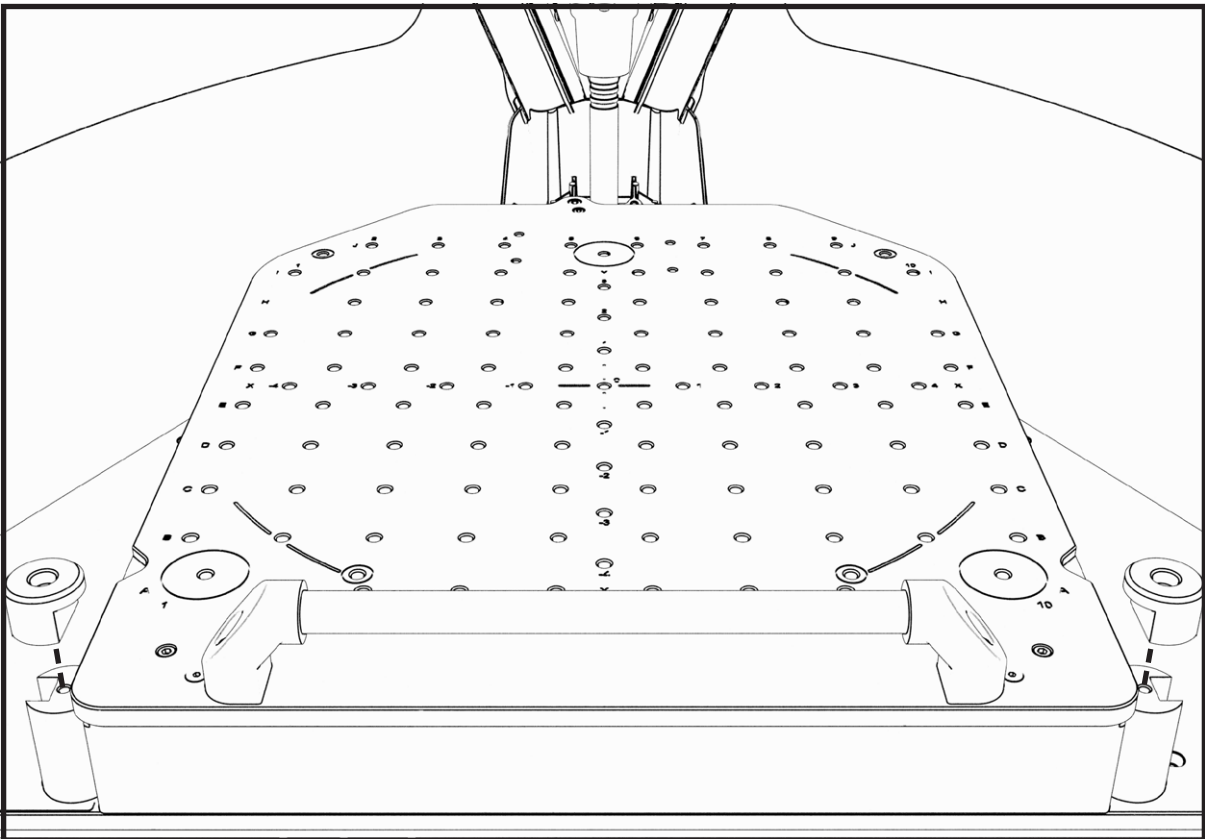

3. Remove bolt

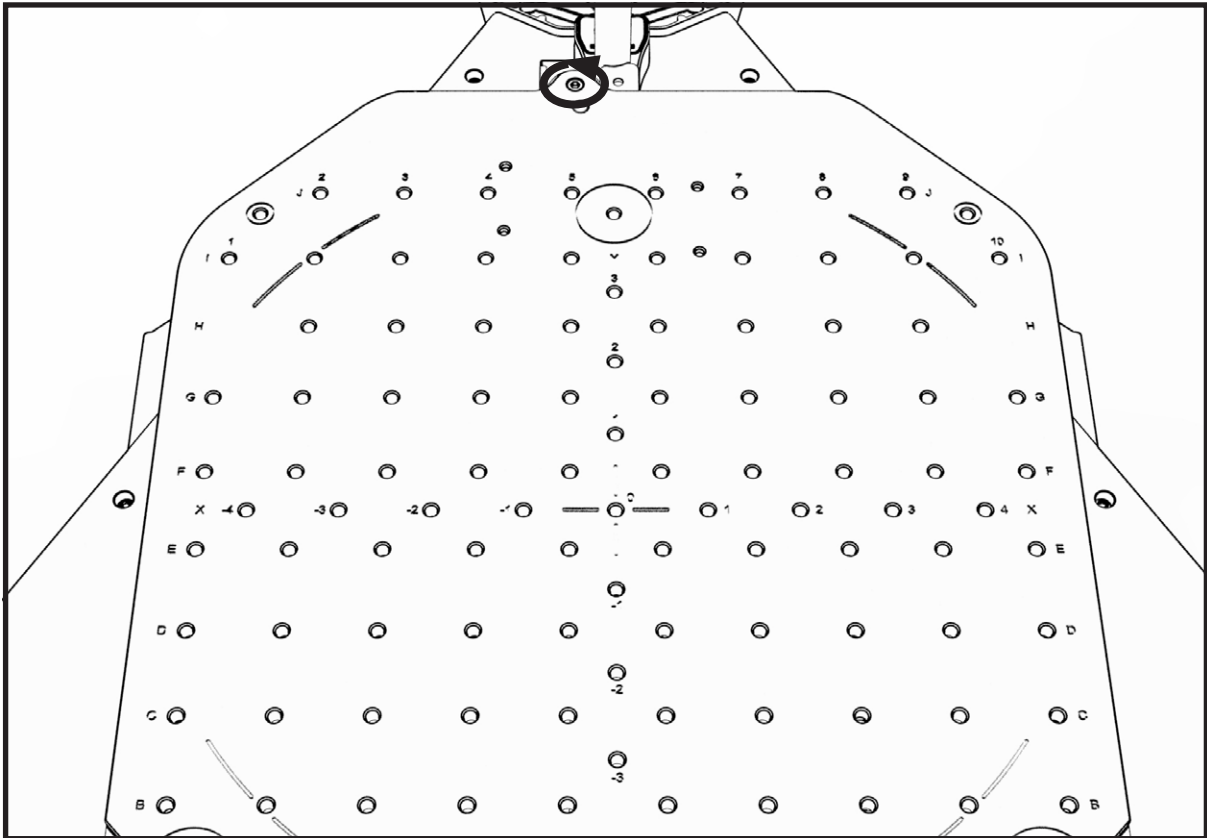

4. Remove bolts from cable chain

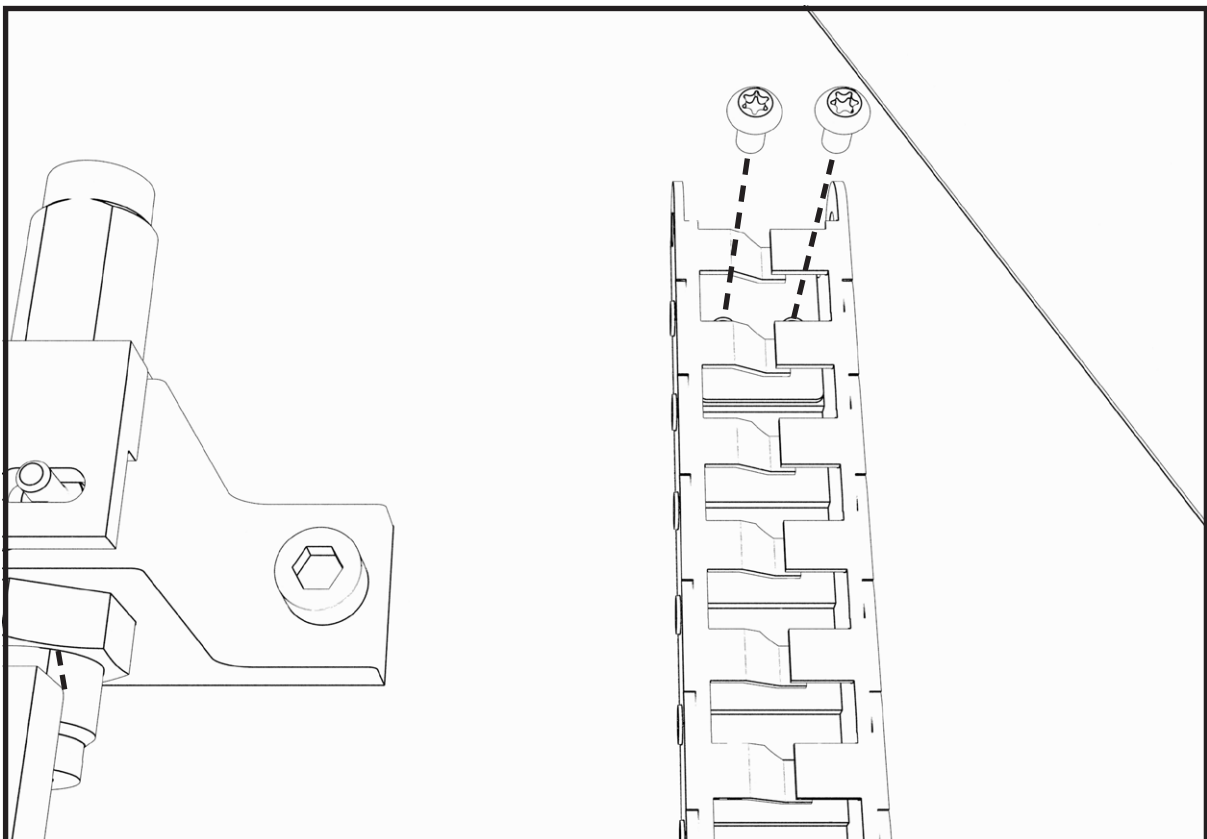

5. Remove tile

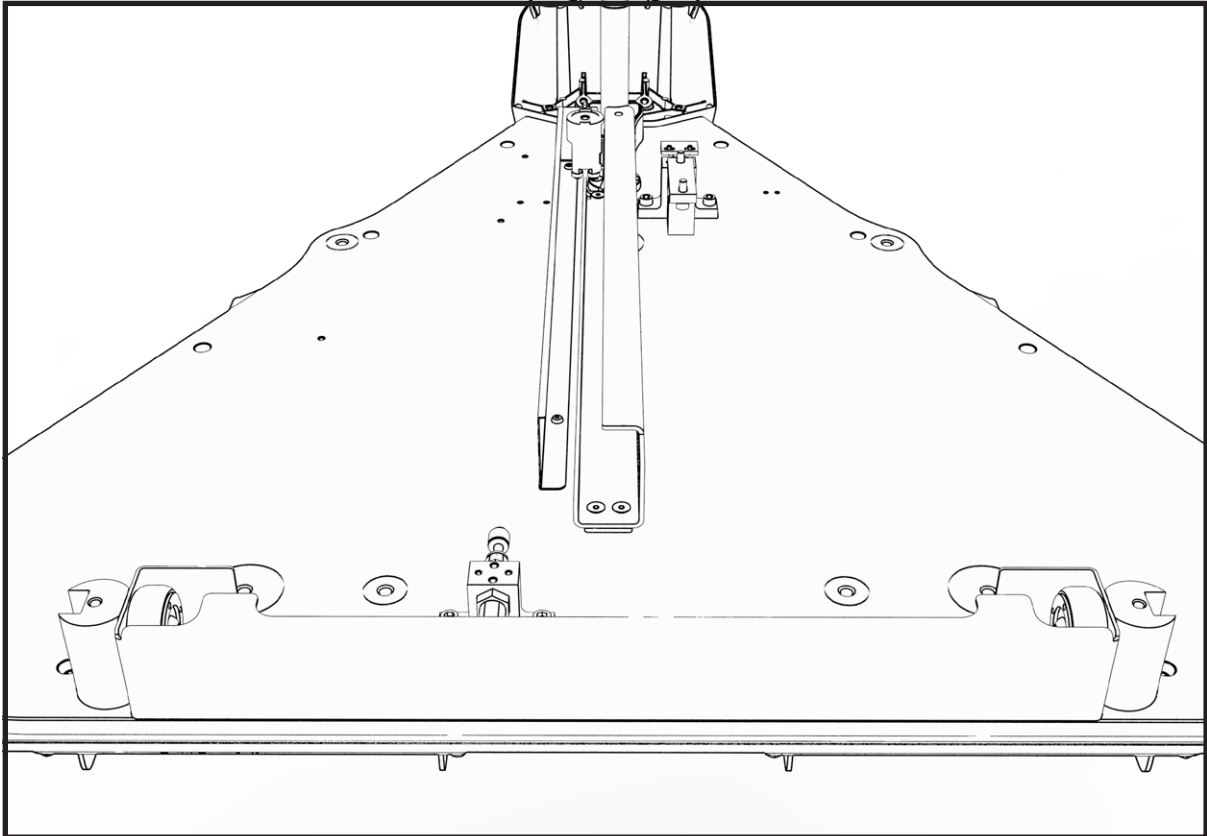

6. Install interlock tang using 2x M4x12 mm bolts

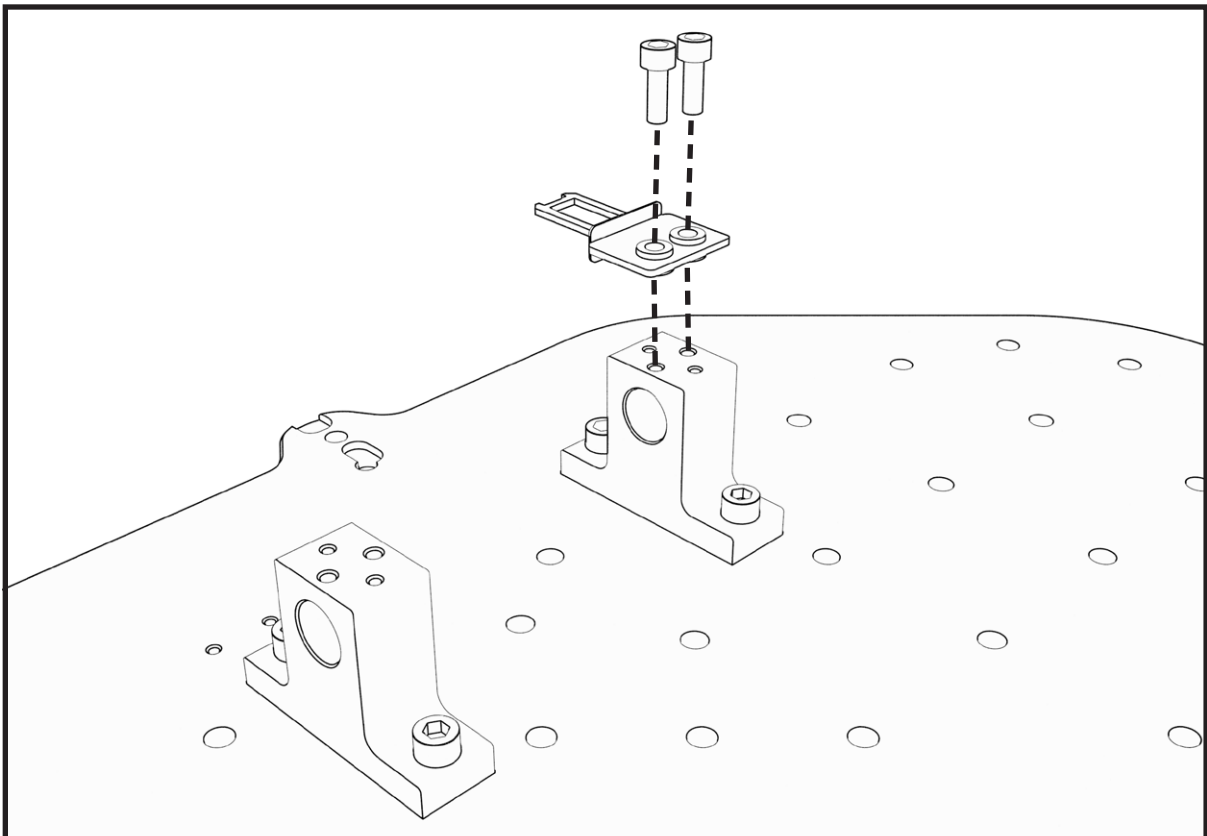

7. Bolt interlock into holes in base of machine using 3x M4x45 mm bolts

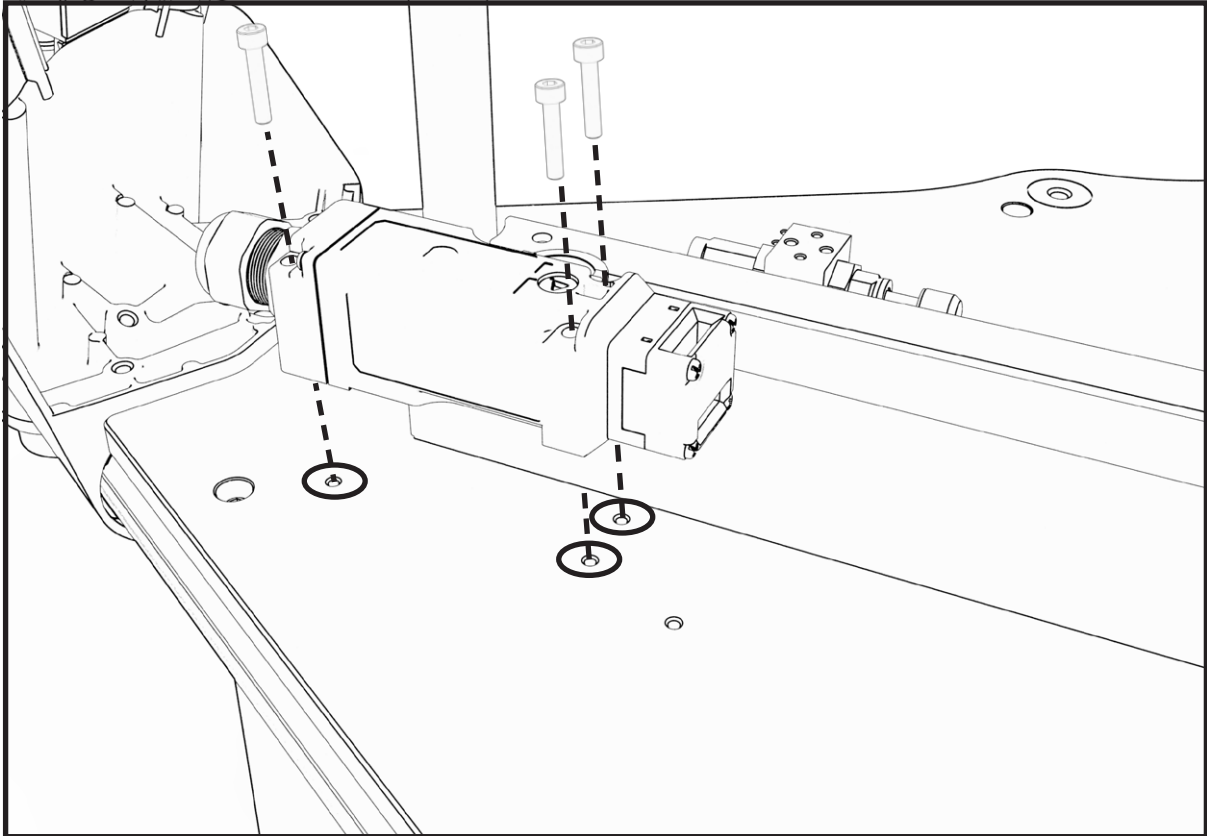

8. Feed interlock cable through the slot in the back cover of the machine

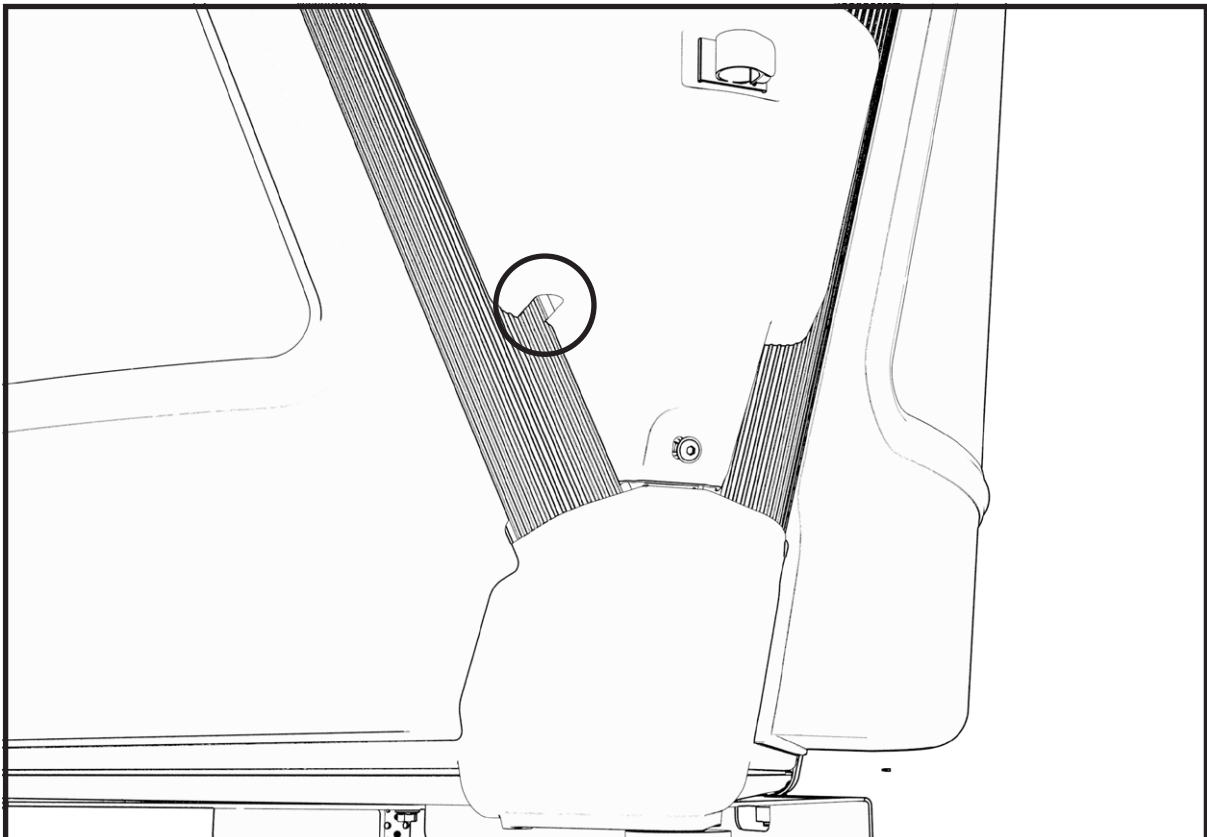

9. Route cable as shown below

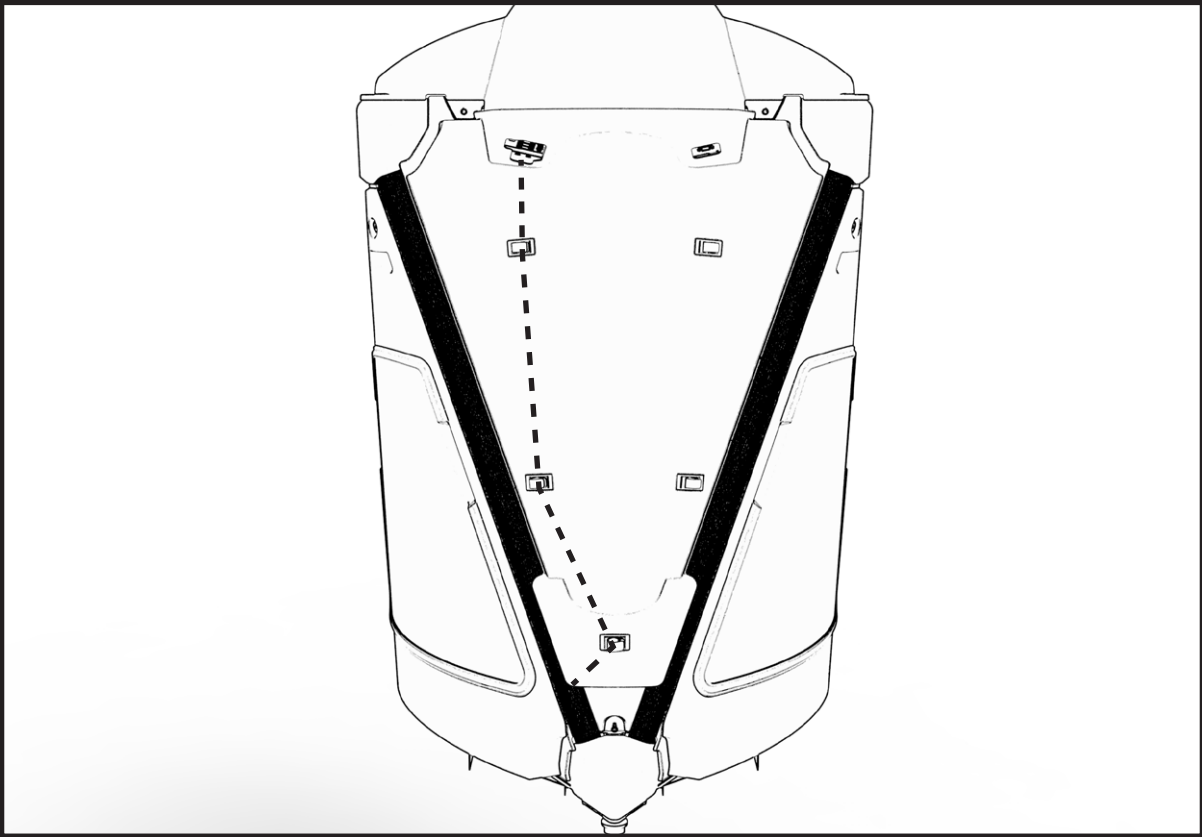

10. Plug interlock cable into machine

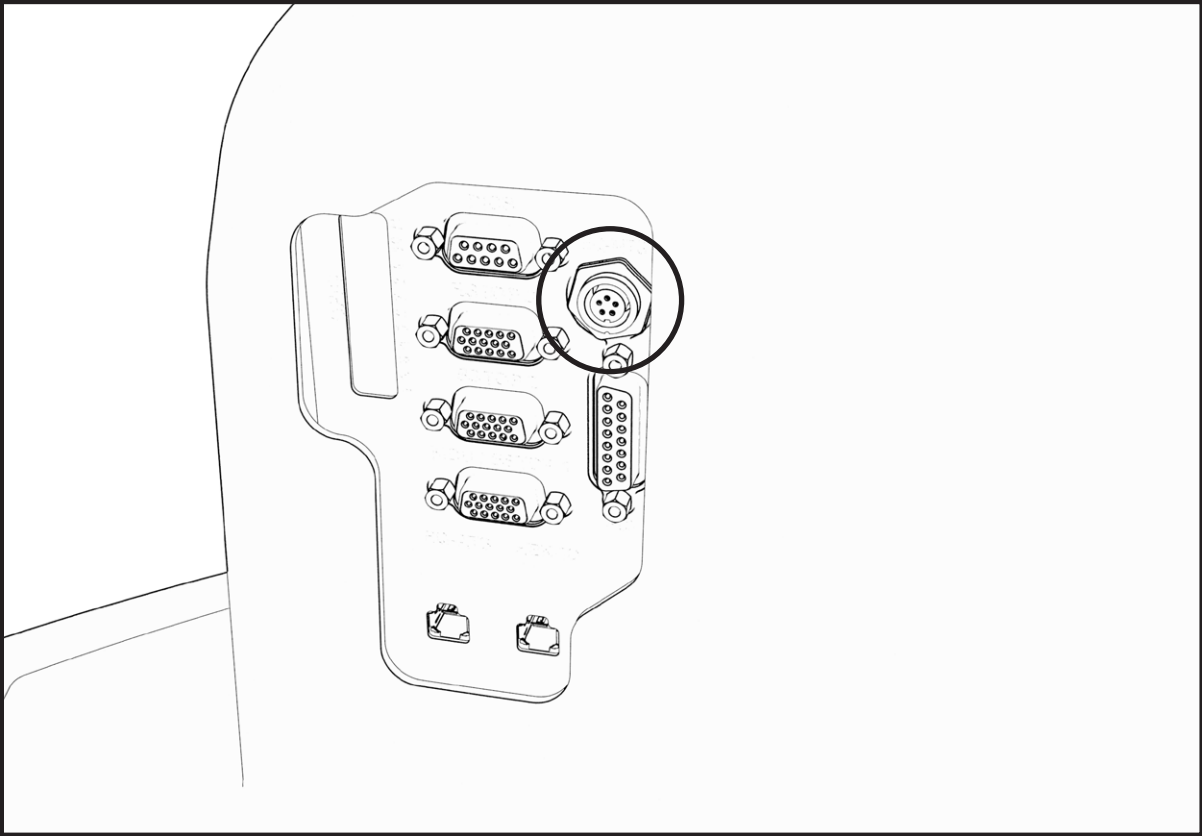

11. Re-install tile

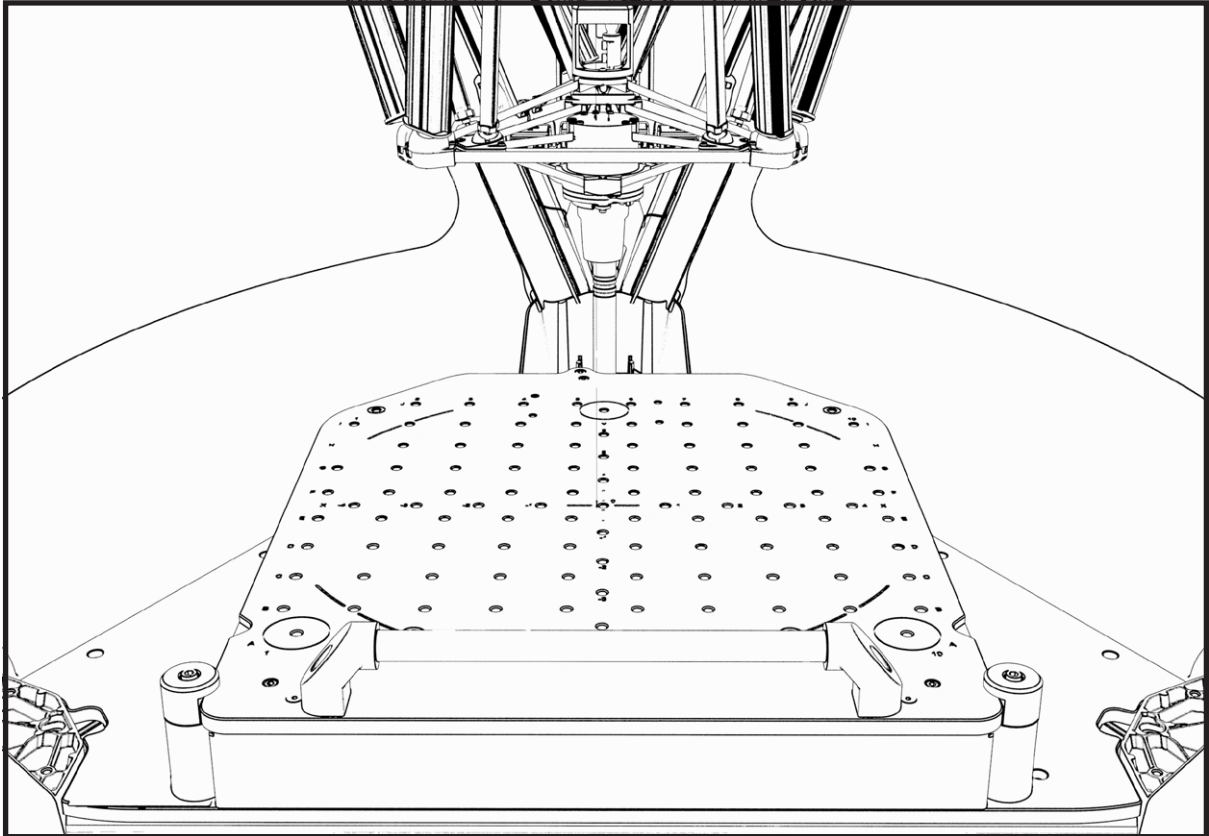

12. Make sure the Tile Restraints are located correctly by gauging an equal distance of 0.3 mm between the Tile Restraints inside face and the edge of the top tile.

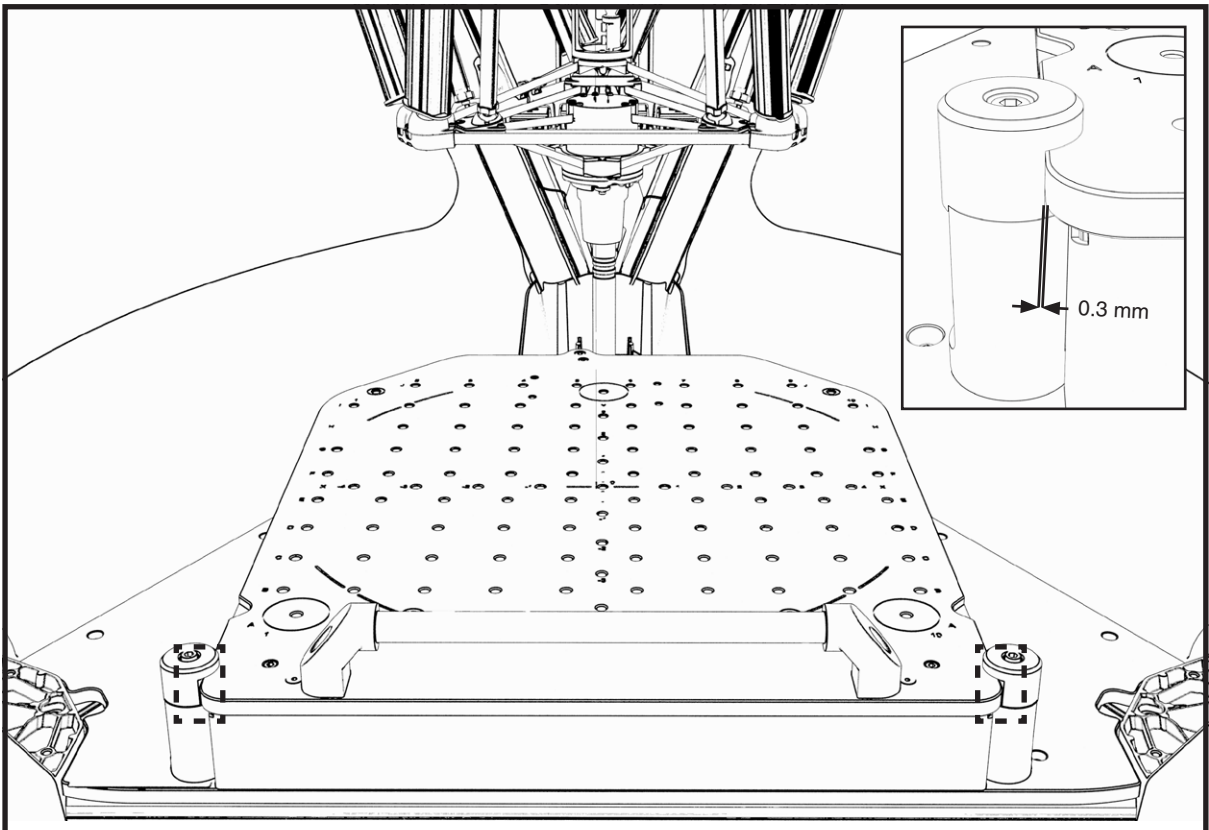

PAGE INTENTIONALLY LEFT BLANK

[www.renishaw.com/gauging](http://www.renishaw.com/gauging)



#renishaw

 +44 (0) 1453 524524

 [uk@renishaw.com](mailto:uk@renishaw.com)

© 2024 Renishaw plc. All rights reserved. This document may not be copied or reproduced in whole or in part, or transferred to any other media or language by any means, without the prior written permission of Renishaw.

RENISHAW® and the probe symbol are registered trade marks of Renishaw plc. Renishaw product names, designations and the mark 'apply innovation' are trade marks of Renishaw plc or its subsidiaries. Other brand, product or company names are trade marks of their respective owners.

WHILE CONSIDERABLE EFFORT WAS MADE TO VERIFY THE ACCURACY OF THIS DOCUMENT AT PUBLICATION, ALL WARRANTIES, CONDITIONS, REPRESENTATIONS AND LIABILITY, HOWSOEVER ARISING, ARE EXCLUDED TO THE EXTENT PERMITTED BY LAW. RENISHAW RESERVES THE RIGHT TO MAKE CHANGES TO THIS DOCUMENT AND TO THE EQUIPMENT, AND/OR SOFTWARE AND THE SPECIFICATION DESCRIBED HEREIN WITHOUT OBLIGATION TO PROVIDE NOTICE OF SUCH CHANGES.

Renishaw plc. Registered in England and Wales. Company no: 1106260. Registered office: New Mills, Wotton-under-Edge, Glos, GL12 8JR, UK.

Part no.: H-6620-8645-01-A

Issued: 04.2024