

XK20 alignment laser





Contents

XK20 hardware	3	XK20 measurements	24
XK20 alignment laser	4	Measurement modes	25
System components	5	Performance specifications	27
XK20 fixturing kit	7	Squareness	29
System specifications	12	XK20 analysis	33
Power supply	14	Data fitting methods	34
Weights and dimensions	14	ISO standards	35
Launch unit	15	ISO standard analysis explained	36
Display unit	16	Renishaw 2012 analysis explained	37
M unit	17	Appendix A	38
Pentaprism optic	18	XK20 filtering	38
Pentaprism translation stage	19	Appendix B	39
XK20 software	20	Parallelism – combined horizontal and vertical	39
Display unit and software overview	21		
Updating the XK20 display unit software	22		
Data transfer	22		
Reference rail and secondary rail	23		

XK20 hardware



XK20 Hardware	XK20 Software	XK20 Measurements
XK20 Analysis	Appendices	Squareness



XK20 alignment laser

XK20 is an alignment laser kit capable of performing various tasks including but not limited to:

- Machine tool alignment to recognised standards during manufacture
- Set up of manufacturing lines
- Service activity, such as machine realignment
- Pre-machining alignment

Measurement capability includes:

- Straightness
- Long range straightness
- Squareness
- Parallelism
- Level
- Flatness





System components

1	Launch unit A laser transmitter with a 360 degree sweeping head and pentaprism optic.
2	S unit The 'Stationary' unit, containing a position sensitive detector (PSD).
3	M unit The 'Motion' unit, containing a position sensitive detector (PSD).
4	Display unit A touch screen tablet containing the measurement software and user guide.
5	Low profile magnetic base A magnetic base used for mounting the S unit, M unit, pentaprism or Launch unit in conjunction with other brackets and accessories.
6	Tripod translation stage The tripod translation stage allows for precise translation of the Launch unit. A fail-safe, quick release mechanism allows mounting to a tripod.
7	Launch L-bracket Upright bracket that enables the user to mount the Launch unit at a 90 degree angle.
8	M6 pillars × 4 150 mm pillars that can be screwed into magnetic bases for mounting the S unit, M unit and pentaprism optic.
9	M6 short pillars × 4 70 mm pillars that can be screwed into magnetic bases for mounting the S unit, M unit and pentaprism optic.
10	Universal power supply kit (not pictured) This includes; 1 × power supply and 3 × kettle leads for UK, EU and USA sockets.
11	DC split cable (not pictured) This cable allows for the charging of three system devices from a single power source (Launch unit, M unit and S unit).



NOTE: To see the parts used in different set-up assemblies, refer to the *XK20* Hardware guide (Renishaw part no. H-9971-9037).



System components continued

1	Pentaprism optic The pentaprism optic can be used to reflect the beam 90 degrees for horizontal parallelism measurements and some squareness measurements.
2	Launch spindle mount The launch spindle mount is used to mount the Launch unit into a spindle or chuck for rotational measurements.
3	Transceiver spindle bracket The transceiver spindle bracket is used to mount either the M unit or the S unit in a spindle or chuck for rotational measurements
4	90 degree transceiver bracket The 90 degree transceiver bracket can be screwed onto either the M unit or the S unit to allow 90 degree mounting when used with the magnetic bases, mounting posts or spindle brackets.
5	Transceiver lowering bracket The transceiver lowering bracket enables the lowering of the M unit when fixtured to the rotary magnetic base.
6	Pentaprism translation stage The pentaprism translation stage is for use with the pentaprism optic to allow lateral adjustment during measurements. The stage is mounted to a low profile magnetic base.
7	Rotary magnetic base The magnetic base has a rotating head so that the M unit can be rotated when taking flatness measurements. The base has an on/off switch. It is used for mounting the M unit or S unit in combination with the M6 pillars.
8	Tripod The tripod provides a stable mounting for the Launch unit and allows the height to be adjusted.
9	Magnetic reference mount The magnetic reference mount enables the M unit to be magnetically mounted against the reference edge of a casting. The M unit can be mounted in a fixed position or on to the rotary head of the magnetic reference mount.
10	USB-DC adapter The USB-DC adapter is used to charge the Launch unit via the display unit.





XK20 fixturing kit

1	Extrusions Aluminium box section extrusions (350 mm, 250 mm and 2 × 200 mm) that can be connected together in numerous variations using the supplied connectors.
2	Extrusion connectors × 12 6 off universal fastenings and 6 off universal butt fastenings that can be used to connect extrusions.
3	Magnets × 6 These magnets are used to fix the extrusion securely to a machine bed or casting.
4	Position discs × 3 These discs are used to position the extrusion on the machine bed and prevent lateral movement.
5	Hex drivers (4 mm, 5 mm) Allen keys to fasten extrusion connectors, position discs and magnets.
6	Launch unit extrusion mount The mount allows the Launch unit to be attached to an extrusion for more versatile mounting. The Launch unit can be fixed to the plate using the built in magnetic feet. The plate is lined with 8 through holes for mounting to an extrusion with the provided connectors.

NOTE: To see the parts used in different set-up assemblies, refer to the *XK20* Hardware guide (Renishaw part no. H-9971-9037).

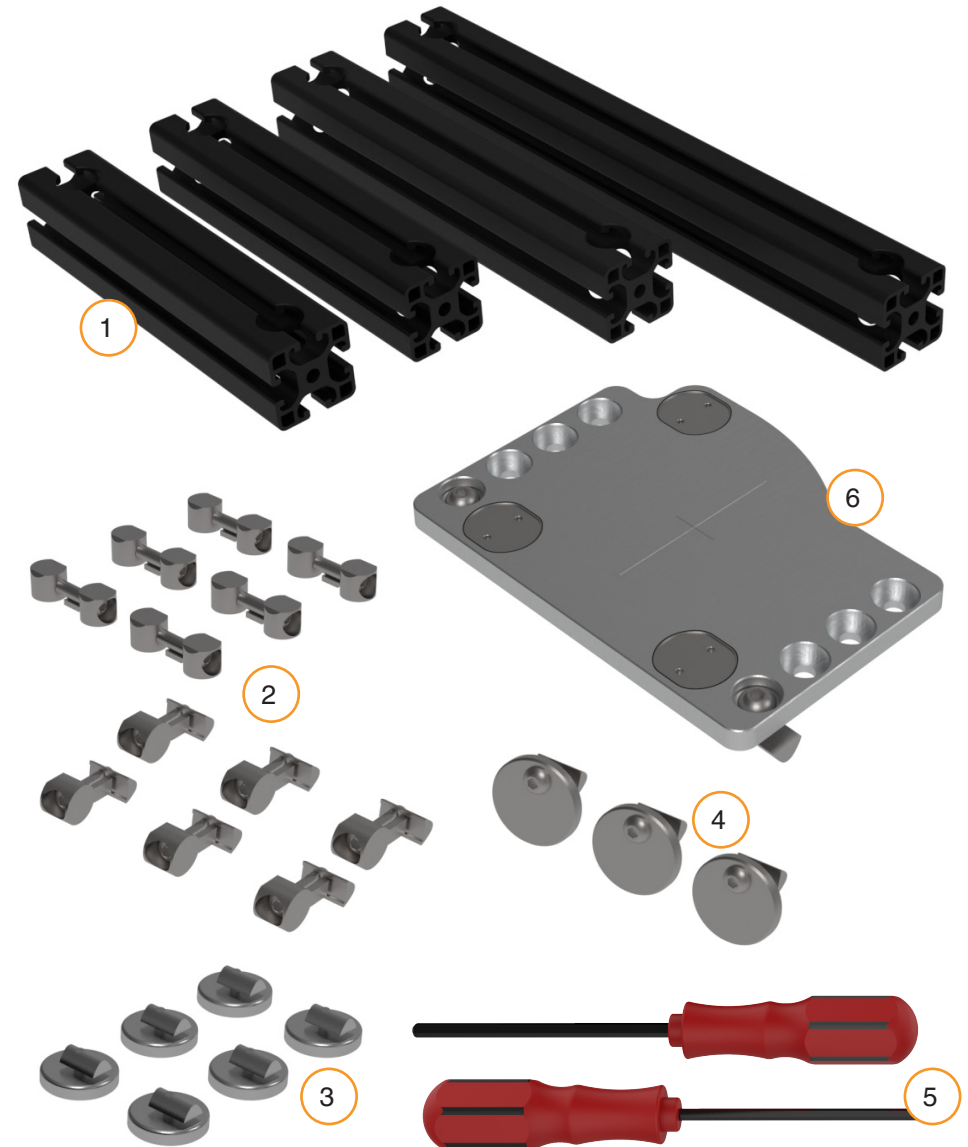



Launch unit

The Launch unit contains a fibre-coupled diode laser, which produces a stable Class 2 output laser beam.

The output beam can be flipped between two orientations using the pentaprism optic in the sweeping head.

Charging

WARNING: Do not conduct a measurement whilst the Launch unit is charging.

The Launch unit contains a rechargeable lithium-ion battery and is charged using the power supply. It can also be charged via the XK20 display unit in conjunction with the USB-DC adaptor and split cable.

Multiple devices can be charged at once using the power supply and the split cable.

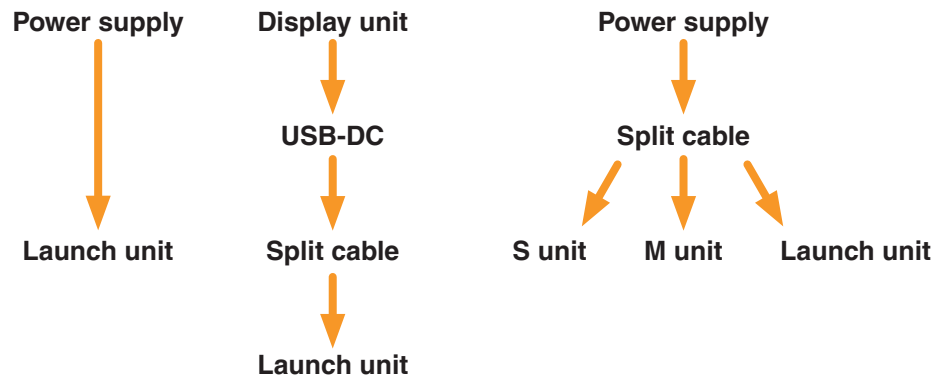

It is recommended that the Launch unit should be charged before or after every use to maintain the battery. Specifications about the power supply can be found on **page 14**.



1	Power on/off, change display view
2	Display
3	Laser head
4	Fine head adjustment dial

5	Pitch/yaw screw
6	Release lever
7	Charging port
8	Launch pentaprism



Launch unit continued

2 Display screen examples

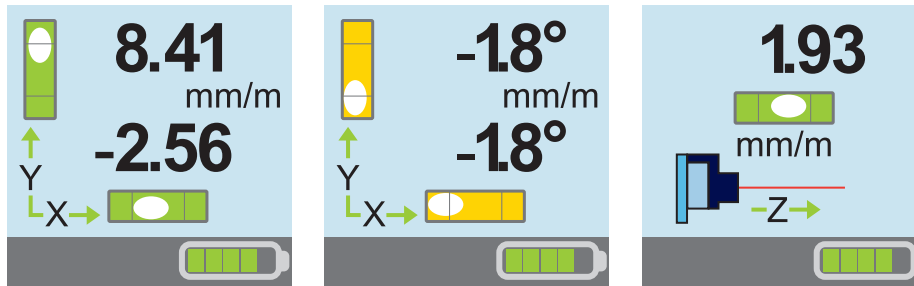

The Z axis is displayed only when the Launch unit is oriented as shown on screen, with the Renishaw label facing upward.

The display will show changes up to 10 mm per 1 m (mm/m) after which the units will appear as degrees.



M unit and S unit

The M unit is a wireless device used as the main detector in all measurements.

The S unit is a wireless device primarily used in rotational alignment applications.

The detection of position is provided by a 2-axis position sensitive diode (PSD). The unit features a Class 2 laser diode output which allows the device to be used with the M unit.

Charging

WARNING: Do not conduct a measurement whilst the M unit and S unit are charging.

The M unit and S unit both contain a rechargeable lithium-ion battery. The M unit and S unit are charged using either the power supply (one unit at a time) or with the power supply and the split cable (multiple units charging).

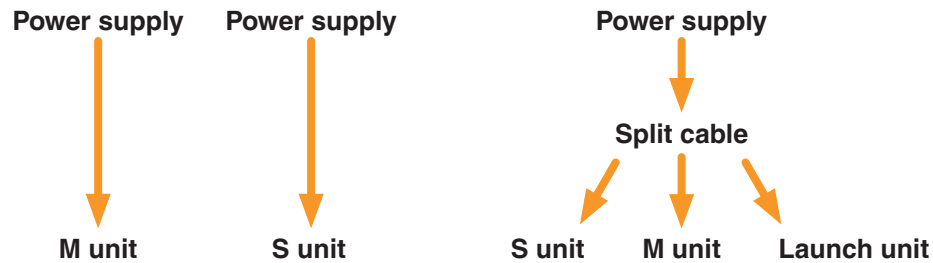

It is recommended that the M unit and S unit should be charged before or after every use to maintain the battery.

Specifications about the power supply can be found on **page 14**.

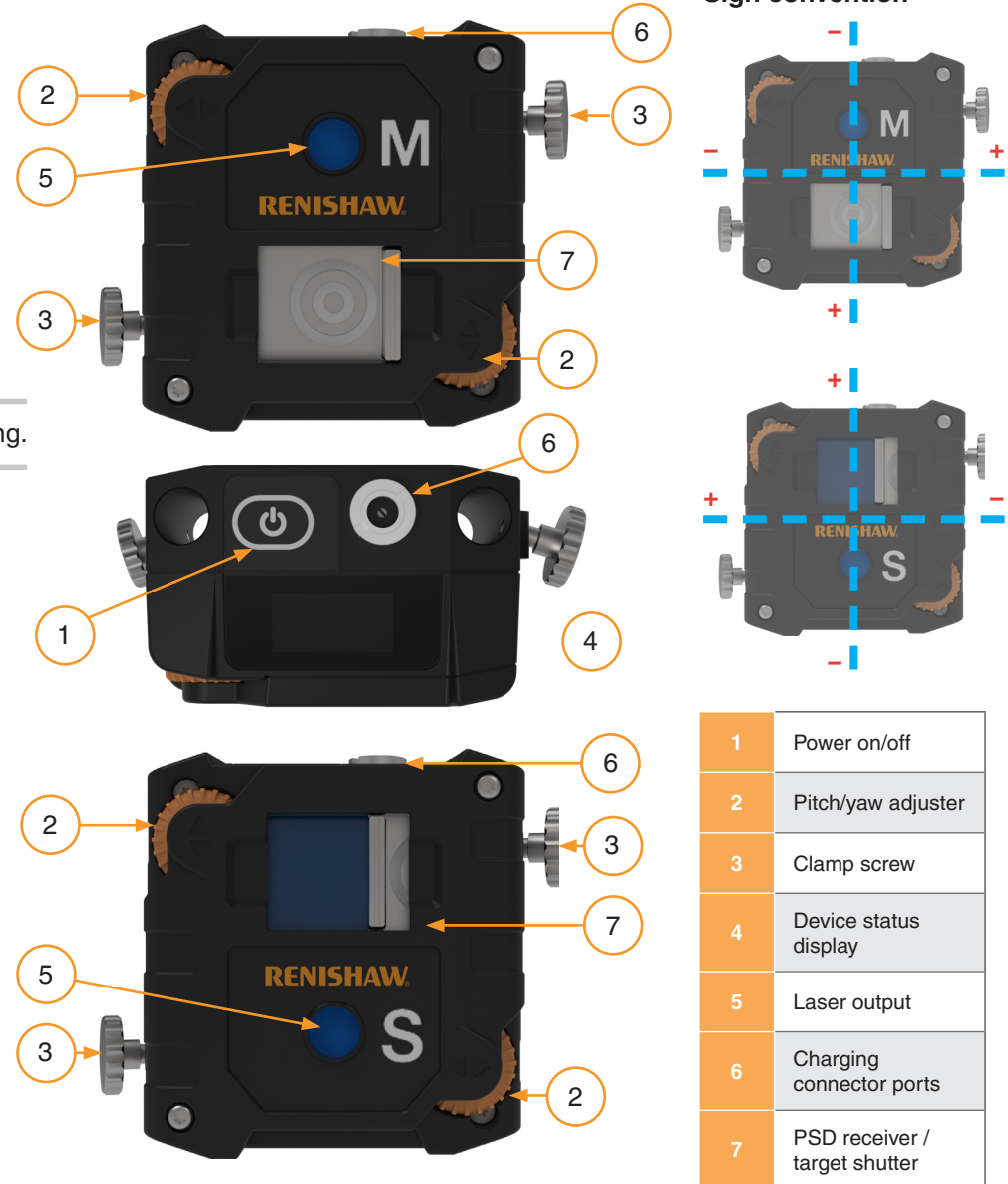

1	Power on/off
2	Pitch/yaw adjuster
3	Clamp screw
4	Device status display
5	Laser output
6	Charging connector ports
7	PSD receiver / target shutter



Display unit

The display unit is used for hardware set up and data capture.

Charging

WARNING: Do not conduct a measurement whilst the display unit is charging.

The display unit contains a rechargeable lithium-ion battery and is charged using the power supply.

NOTE: Only the Launch unit can be charged from the display unit, via the USB-DC and split cable.

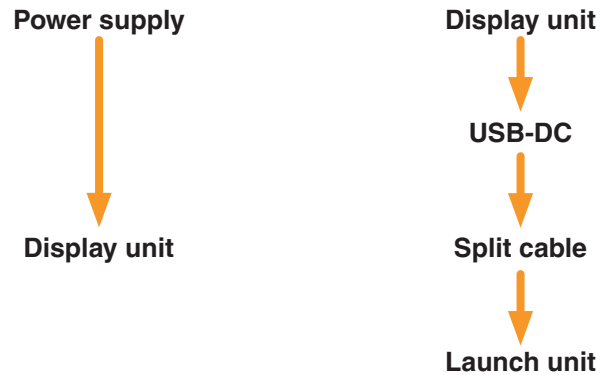

It is recommended that the display unit should be charged before or after every use to maintain the battery.

Specifications about the power supply can be found on **page 14**.



1	Battery status button
2	Power on/off
3	'Capture' button
4	Touch screen
5	Battery status LED's

6	HDMI port
7	USB A port - connection for the USB-DC adapter
8	USB C port - for data transfer (see ' Data transfer ') and charging
9	DC-IN port - for charging with the power supply



System specifications

Launch unit	
Beam measurement range	40 m
Laser output	Class 2
Dimensions	147 mm × 136 mm × 152 mm
Weight	2.26 kg
Power	2 × Lithium-ion (7.4 Wh) internal batteries
Operating time	~30 hours
Warm-up time	15 min <i>Valid when the unit has been stored in room temperature and measurement takes place in the same environment.</i>
Digital spirit level accuracy	20 µm/m +/-1%
Digital spirit level resolution	0.001mm/m
IP rating	Designed for industrial use (pollution degree 3)

M unit and S unit	
Beam measurement range	20 m
Laser output	Class 2
Dimensions	76 mm × 76.4 mm × 45.9 mm
Weight	272 g
Power	Lithium-ion (7.4 Wh) internal battery
Operating time	~24 hours
Warm-up time	~30 minutes
Inclinometer accuracy	±1°
Inclinometer resolution	0.1°
IP rating	IP 66/67 (IEC 60529)

XK20 Hardware	XK20 Software	XK20 Measurements
XK20 Analysis	Appendices	Squareness



Display unit	
Dimensions	269 mm × 190 mm × 49.4 mm
Weight	1.4 kg
Power	Lithium-ion (68.04 Wh) internal battery
Operating time	~16 hours (internal battery only)
Screen size	8 in
Wireless range	30 m
IP rating	IP 66/67 (IEC 60529)

XK20 system	
Specified accuracy range	-10 °C to 50 °C
Recommended recalibration period	2 years <i>To arrange recalibration for your product, contact your local Renishaw office. Further details can be found online.</i>

System storage and transportation environment

Storage and transportation	
Temperature	-20 °C to +50 °C
Pressure	1000 mb – 700 mbar
Humidity	10 % to 95% RH (non-condensing)



Power supply

Power supply	
Input voltage	100 V to 240 V
Input frequency	63Hz
Maximum input current	2.0 A
Output voltage	15 V
Maximum output current	4 A
Safety standard	EN 62368

NOTE: The power supply has been qualified for use with the XK20 system. Do not use an alternative power supply. If the power supply becomes damaged or lost, a new supply can be purchased from **Renishaw's online store** or contact your **local Renishaw office**.

Weights and dimensions

Item	Weight (approximately)
XK20 system	Maximum 25 kg
Launch unit	2.26 kg
Display unit	1.4 kg
M unit	272 g
S unit	272 g

XK20 Hardware	XK20 Software	XK20 Measurements
XK20 Analysis	Appendices	Squareness



Launch unit

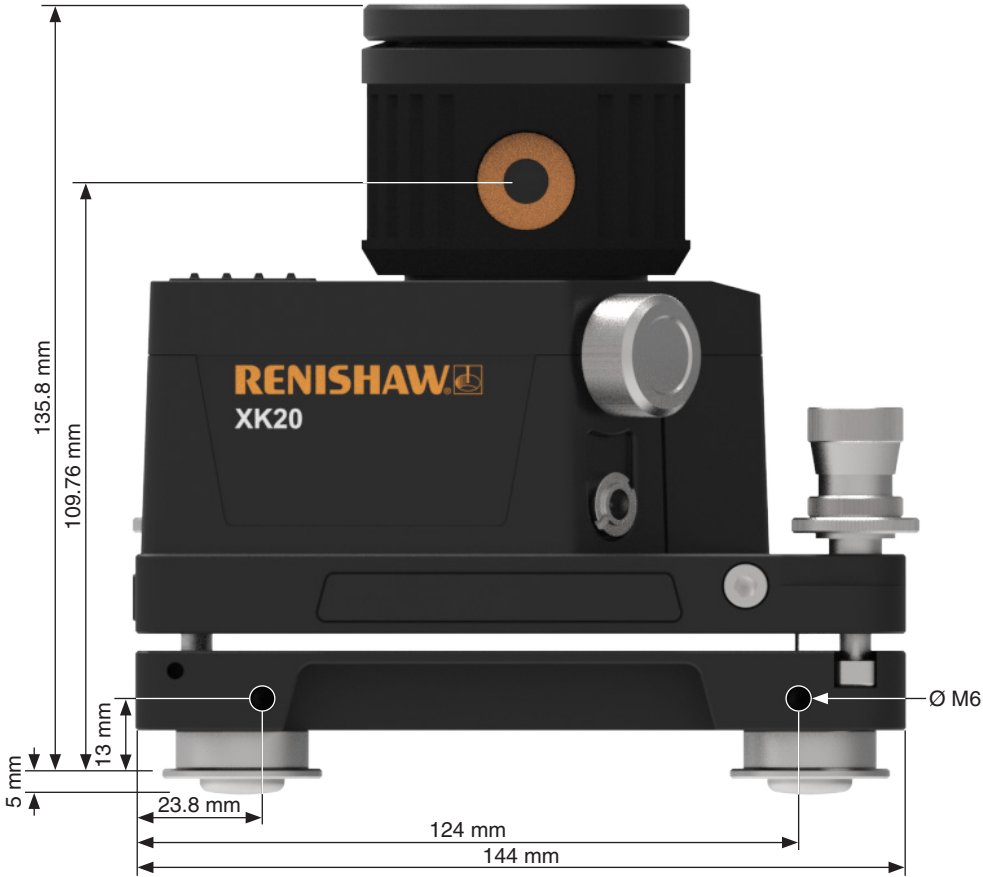
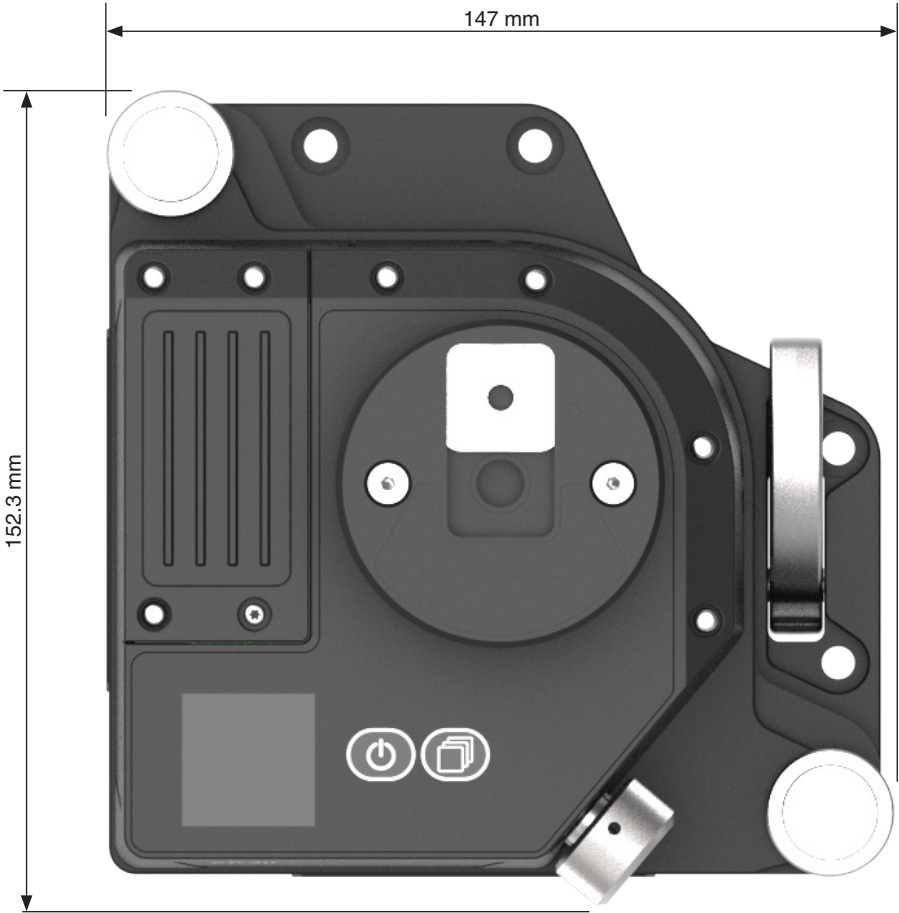

XK20 Hardware	XK20 Software	XK20 Measurements
XK20 Analysis	Appendices	Squareness



Display unit



XK20 Hardware	XK20 Software	XK20 Measurements
XK20 Analysis	Appendices	Squareness



M unit

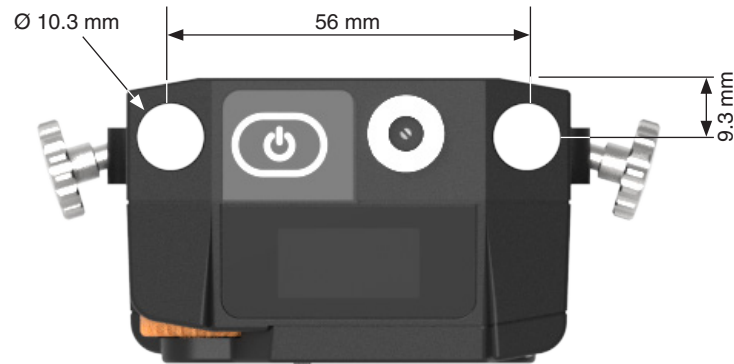

XK20 Hardware	XK20 Software	XK20 Measurements
XK20 Analysis	Appendices	Squareness



Pentaprism optic

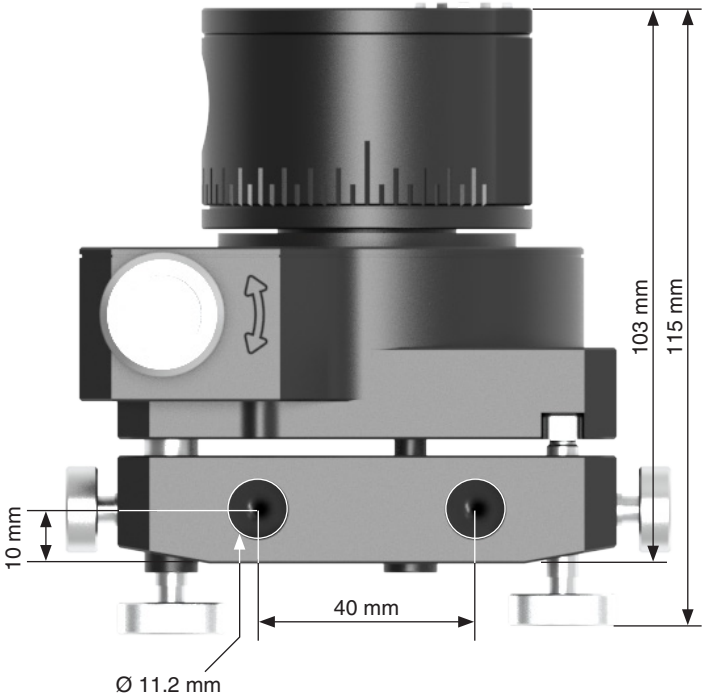
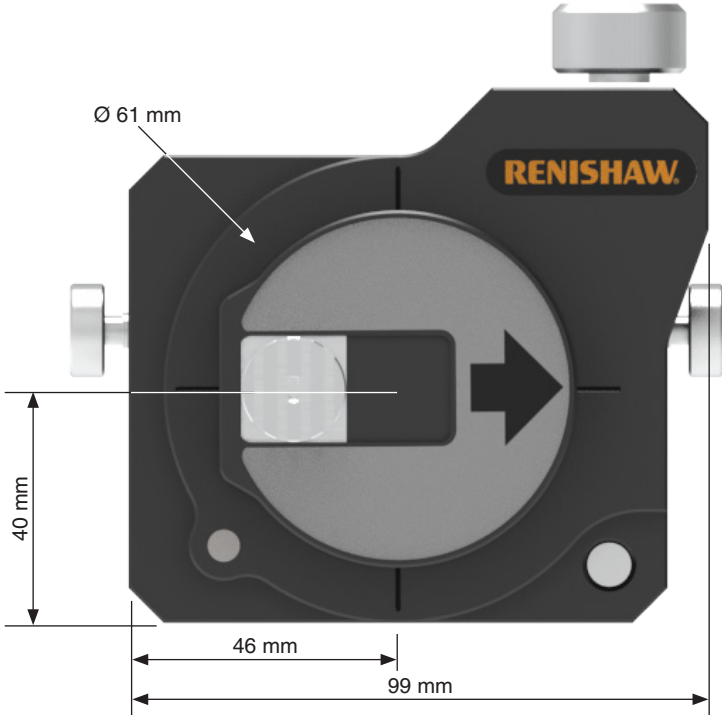



Pentaprism translation stage

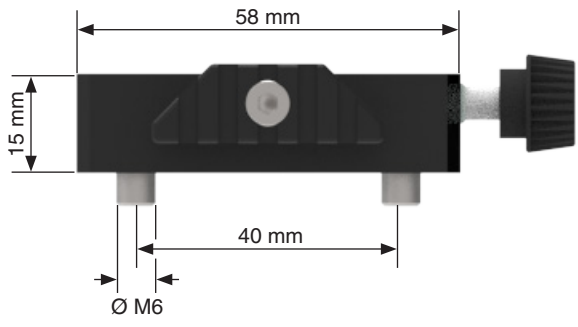
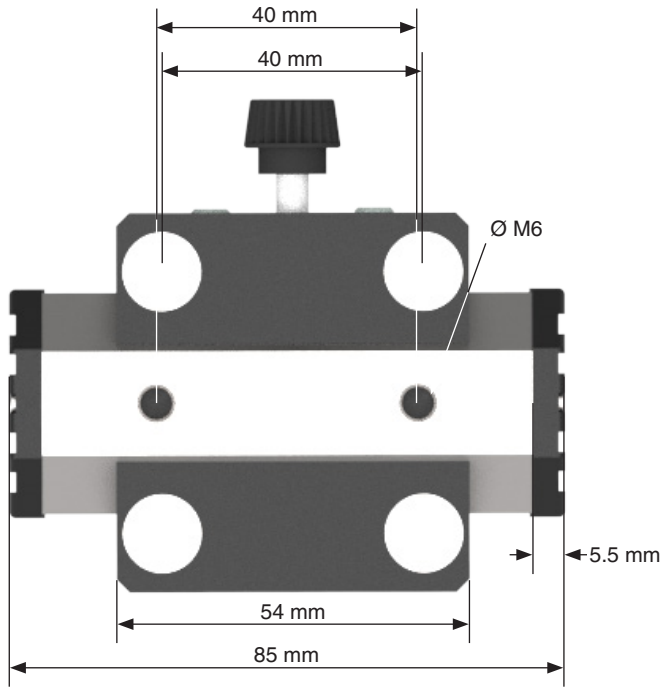

XK20 software





Display unit and software overview

Abbreviations

The software uses a range of abbreviations. Whilst they may be clear in context, the table below shows their long form:

Abbreviation	Long form
Std. Dev.	Standard deviation
Pos	Position
H	Horizontal
V	Vertical
Ref	Reference
Sec	Secondary
M-H	M unit – horizontal
M-V	M unit – vertical
H Ref	Horizontal reference
V Ref	Vertical reference
H Sec	Horizontal secondary
V Sec	Vertical secondary
H Par	Horizontal parallel straightness
V Par	Vertical parallel straightness
Max	Maximum
Min	Minimum



NOTE: If using the XK20 display unit, software updates can be found on the Renishaw website (www.renishaw.com/calsoftware). See '**Updating the XK20 display unit software**' for further information.

If using a third party tablet, software can be installed and updates will be available from the relevant application store. Search for 'CARTO XK20'.



Updating the XK20 display unit software

The display unit software must be updated manually via USB stick*. It is recommended to check the Renishaw website periodically for software updates. Your local Renishaw office may also send out communications.

1. Download the software from the Renishaw website (www.renishaw.com/calsoftware) and transfer it on to an empty USB stick.
2. Ensure the display unit is turned off. Plug in the USB stick.
3. Power on the display unit. The display unit will load to the home screen.
4. Power off the display unit. Once powered off, remove the USB stick.
5. Power on the display unit. Check the version number has updated in settings.

*Renishaw does not provide a USB stick.

Data transfer

The display tablet has the same function as a hard drive. Data can be transferred from the device to a computer via a USB C cable. The files on the display unit can then be accessed via the computer's file explorer system.

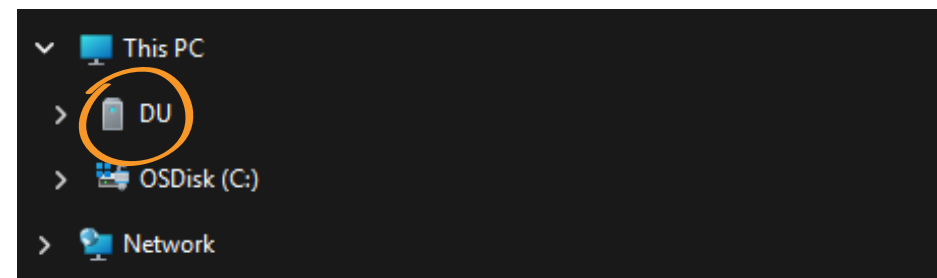
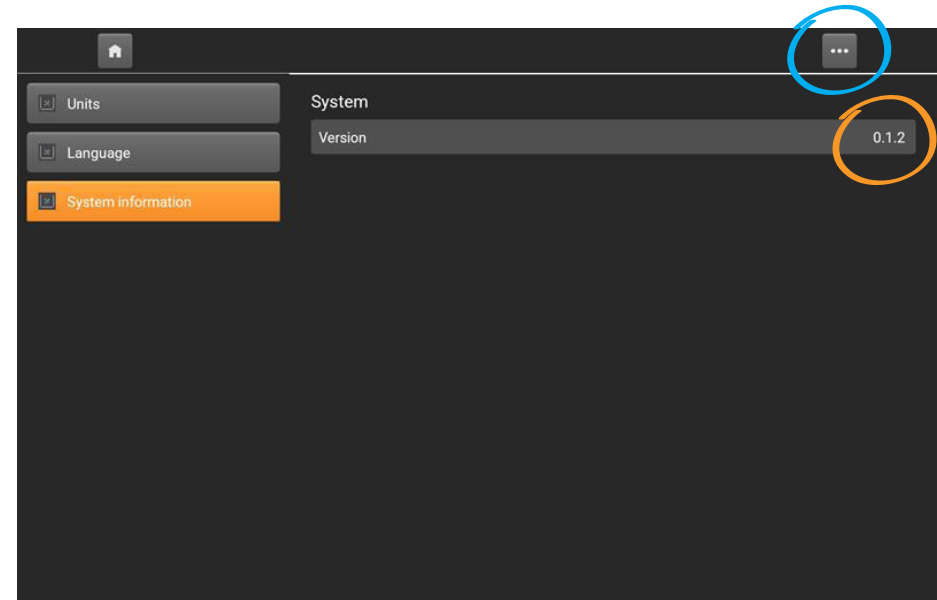



Reference rail and secondary rail

When measuring two rails, the software will refer to a 'reference rail' and a 'secondary rail'. The reference rail is the rail that is measured first. This rail is not adjusted. The secondary rail is measured second and is adjusted as required according to the measurement results.

The difference between the two rails is highlighted visually – an entire rail is orange or is outlined in orange – and sometimes with on-screen descriptions. Some examples of this are as follows:

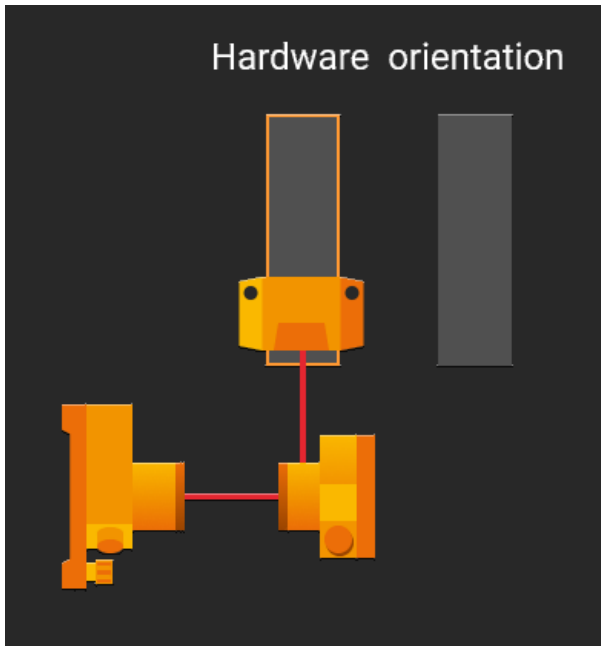

Horizontal parallelism – define screen

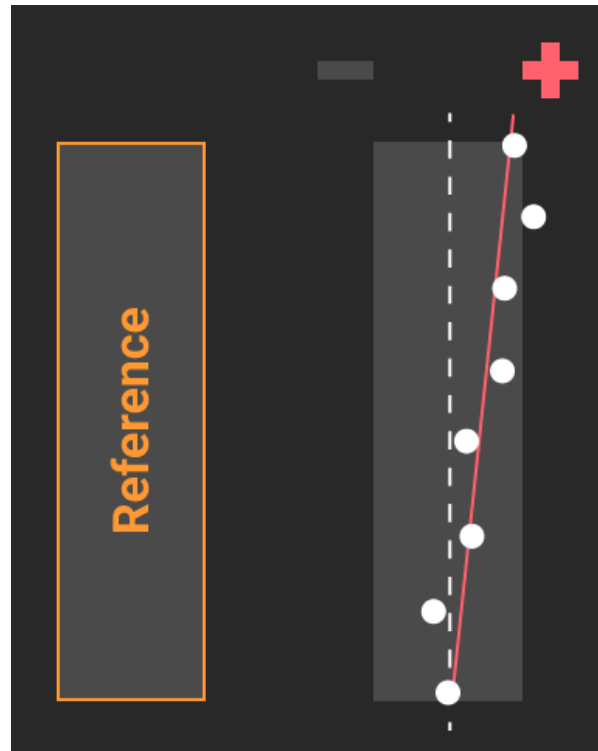

Horizontal parallelism – results screen

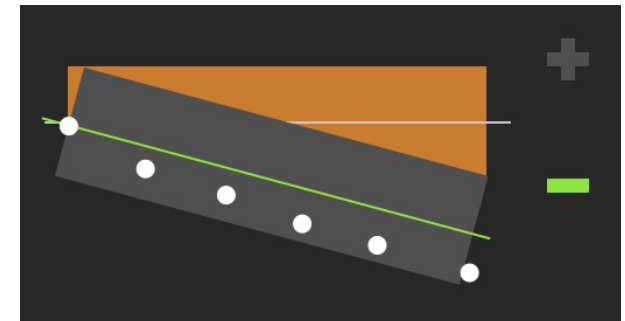





Vertical parallelism – results screen

XK20 measurements



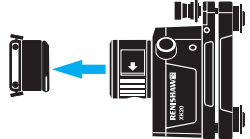

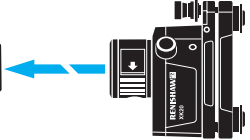

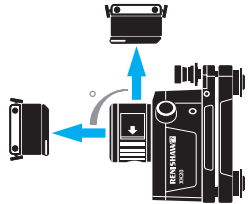

Measurement modes

	<p>Straightness</p> <p>Measures vertical and horizontal straightness along an axis. Used for all machine builds to ensure accuracy when mounting and aligning stages and guideways.</p> <p>This is done by measuring the position of the Launch unit's beam when moving the M unit along the axis under test.</p>	
	<p>Long range straightness</p> <p>Measures vertical and horizontal straightness along an axis. Used for all machine builds to ensure accuracy when mounting and aligning stages and guideways.</p> <p>This is done by measuring the position of the Launch unit's beam when moving the M unit along the axis under test.</p>	
	<p>Squareness</p> <p>Measures the orthogonality of two machine axes. This would typically be used to ensure that machine arms and beds are at right angles, to align machine rails, or when squaring separate machine assemblies.</p> <p>This consists of two straightness measurements done at 90 degrees to one another.</p>	

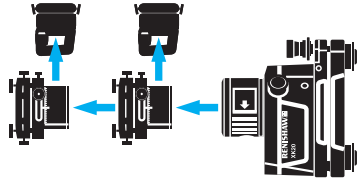

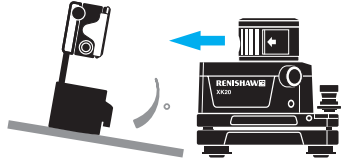
Measurement modes continued

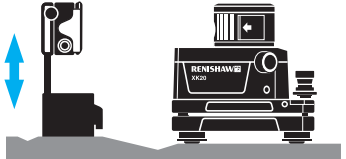
	<p>Parallelism</p> <p>Measures the straightness deviation or overall misalignment angle between two nominally parallel axes. It is typically used during the manufacture of machine tool structures.</p> <p>This is done by using the optional pentaprism optic to direct the beam along the axes, taking measurements with the M unit while keeping the Launch unit as a fixed reference.</p>	
	<p>Level</p> <p>Measures machine level with respect to gravity, or to another machine surface. This is typically used to align machine stages and to check gradual distortion of machine structure over time. It can also be used to level one machine relative to another.</p> <p>This is done by comparing the height of the structure at multiple points to the output of the Launch unit's beam.</p>	
	<p>Flatness</p> <p>Measures vertical deviation along a machine bed, rails, or other machine planes. A versatile mode that can measure continuous or interrupted planes, for example to measure height differences between fixtures or machine sub-assemblies.</p> <p>This is done by measuring the position of the launch beam on the M unit at different points on a plane.</p>	



Performance specifications



Straightness	
Range	±5 mm
Accuracy	±0.008A ±0.8 μm
Resolution	0.1 μm

A = displayed straightness reading (μm)



Squareness	
Range	±5 mm
Accuracy*	±0.008A/M ±1.4/M ±4 μm/m
Resolution	0.1 μm

* with squareness calibration factor

A = straightness reading of the furthest point (μm)
M = length of the (shortest) axis (m)



Parallelism	
Range	±5 mm
Accuracy (i)	±0.008A/M ±1.4/M ±2 μm/m*
Accuracy (ii)	±0.008A ±1.4 ±2M μm*
Resolution	0.1 μm

* laser to pentaprism distance > 0.2 m

A = (largest) straightness reading (μm)

M = length of the axis (m)

- i. To be used when the quantity of interest is the angle between rails.
- ii. To be used when parallelism between rails is:
 - specified as a tolerance zone defined by two parallel lines parallel to a datum axis (for example, reference rail) within where the axis of the feature (for example, measurement rail) must lie.
 - intended as a point by point variation in the separation between the rails, with respect to the separation between the first two points



Flatness		
Range	±5 mm	
Accuracy	±0.01A ±1 ±(1+1.1M) μm	Over a 90° sweep
Resolution	0.1 μm	

A = displayed straightness reading (μm)
M = distance to the furthest point (m)

XK20 Hardware	XK20 Software	XK20 Measurements
XK20 Analysis	Appendices	Squareness



Measurement considerations

Slope error

Slope error is caused by poor alignment. This can be reduced by the following steps:

1. Minimise misalignment of the beam to the axis to reduce PSD scale error by ensuring the software target stays green along the entire rail.
2. End-point fit data to remove residual slope error.

PSD scale error

Large misalignments along the axis increases PSD scale error which is inherent in PSD technology. Aligning the beam within the advised alignment tolerance will minimise this error. Ensuring the beam is aligned as close to the PSD centre as possible will also minimise this error.

Coning

Coning is the process of making the laser beam parallel to the axis of the spindle being measured. This forms a datum from which the spindle direction error can be measured.

Alignment

Alignment is the process of making the laser beam parallel to the axis being measured. This forms a datum from which the straightness deviation along the axis can be measured. Optimal alignment reduces slope error and PSD scale error.

Environment

The environmental conditions during measurements will significantly affect measurement accuracy. The factors listed can introduce noise and drift to measurements. These should be reduced or eliminated where possible before commencing.

- Thermal stability
- Shock and vibration
- Air turbulence

Once minimised, any further noise can be reduced using **filtering or the long range straightness measurement mode (patent pending)**. See **Appendix A for details**.

Alignment tolerances

To minimise slope error and the effects of PSD scale error, aim to align the laser beam to within the following tolerances:

Software tolerance

Ensure the software target stays green along the axis being measured. For numerical values, tap the software target on the screen.

Geometric tolerance

$\pm 100 \mu\text{m}^*$ along the axis being measured.

This is confirmed by the alignment target turning green.

Rotational tolerance

Coning alignment should be $\pm 100 \mu\text{m}^*$ through a 180 degree rotation.

* Environmental conditions permitting



Squareness

When performing a squareness test, the software needs to know the orientation of the M unit on both the reference and secondary axes. This allows the software to re-orientate the sign convention of the data from the PSD and report the correct squareness angle.

Setting up the hardware

Mount the orientation of the XK20 Launch unit so that the fixed beam is pointing along the reference axis. The sweeping beam is used to measure the secondary axis.

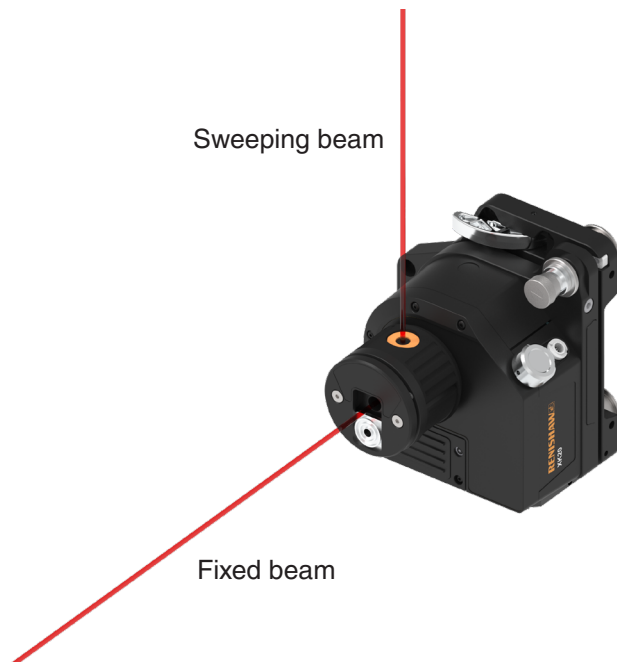

Squareness application builder

During the set up stage of the software, select the corner of the two axis that are being measured. Defining the set-up varies between horizontal squareness and vertical squareness tests.

- Horizontal squareness – the image is based on a plan view of the hardware set-up.
- Vertical squareness – the image is based on a side view of the hardware set-up.

Not set	Reference rail option 1	Reference rail option 2
<p>Hardware orientation</p>	<p>Hardware orientation</p>	<p>Hardware orientation</p>
<p>As default, no selection is made for hardware set-up.</p>	<p>Select the intersection to match the hardware set-up. The software then identifies an axis '1' (reference) and '2' (secondary).</p>	<p>Toggle the reference axis in the software to match the hardware set-up by selecting the XK20 icon.</p>

NOTE: The software will assume the start point of the measurement is located where the two axis intersect.



XK20 squareness options

When carrying out a squareness test, there are two measurement modes to choose from. It is important to use the correct mode as the set up process for horizontal and vertical squareness is not the same.

Horizontal squareness

Use this mode when the reference and secondary rails are both on a horizontal plane relative to the ground.

The software detects the M unit orientation and assigns the correct sign convention when any of the four edges of the M unit are facing ground.

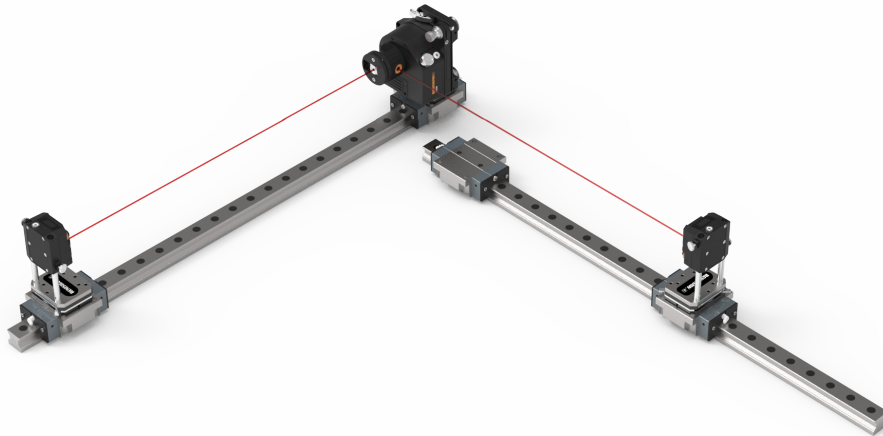

Vertical squareness

Use this mode when one of the rails is vertical relative to the ground.

When capturing the vertical axis, the M unit faces towards, or away from the ground (depending on set-up). The inclinometers cannot read the orientation in this set-up.

During the test set up process, the M unit orientation is set manually.





XK20 squareness using the pentaprism optic

For many applications, the standard horizontal and vertical set-ups offer a suitable solution to measure squareness. There are, however, some applications where alternative solutions or flexibility is required to measure squareness.

For more information, contact your local Renishaw office.

Horizontal set-up

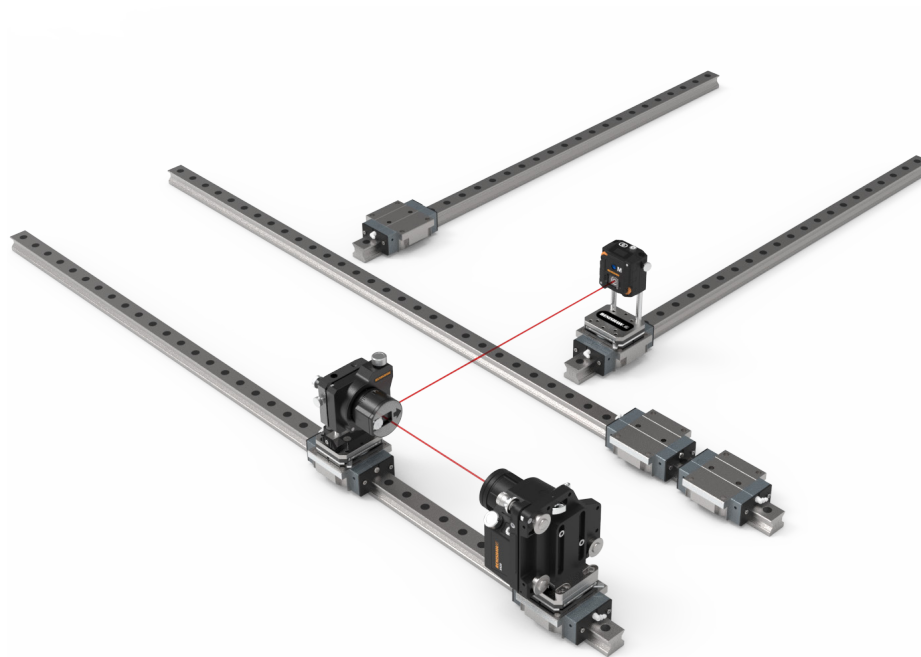

Vertical set-up

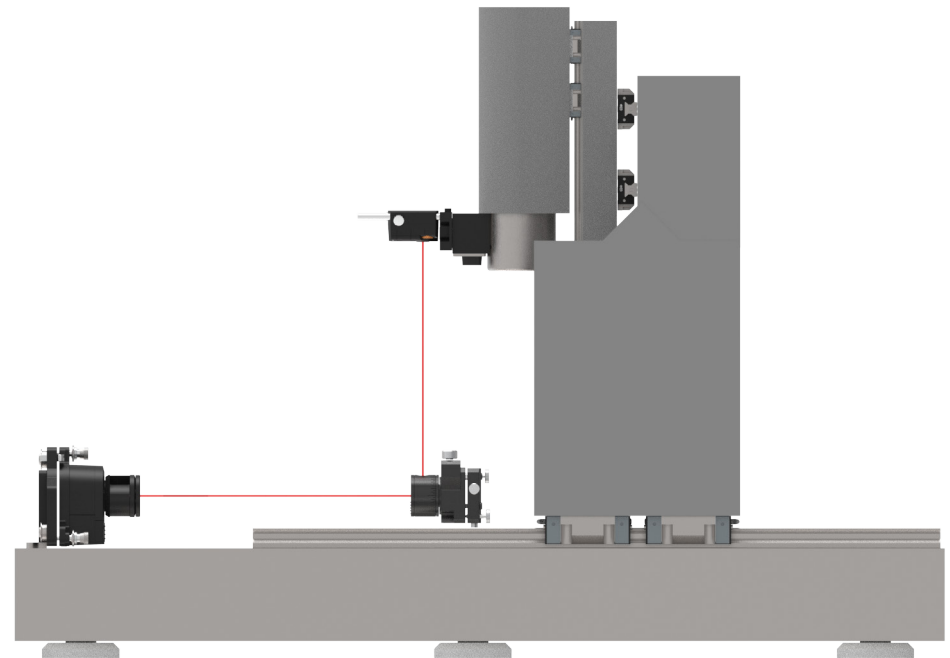



The M unit can be mounted in any orientation. However, the inclination and orientation must be known by the software. The software assigns the relevant straightness deviations of each rail to ensure that the correct squareness angle is calculated.

M unit software inclinometers

XK20 M units have a built-in inclinometer, which allows the software to read its inclination with respect to gravity. Some measurement modes automate the software set up process, ensuring the correct sign convention is assigned to the M unit. For example, if the M unit is rotated 180 degrees (Figure 1), the software counter rotates the sign convention by 180 degrees to the expected default state (Figure 2).

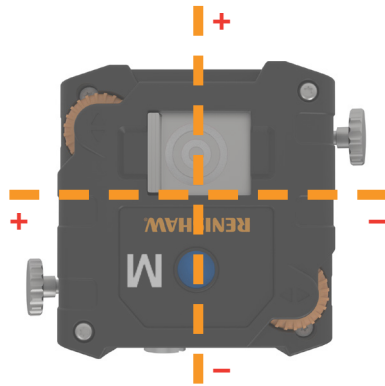

Figure 1: M unit inclination

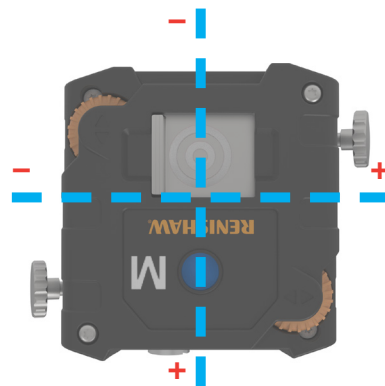

Figure 2: Software corrected sign convention

M unit software orientation

The user must define the orientation of the M unit around the vertical axis on the reference rail. If using the pentaprism, the direction of the laser will change.

Vertical squareness set up

Vertical squareness set up requires the face of the M unit to be parallel to the ground on the vertical axis. This prevents the inclinometers from working and therefore the software cannot detect the orientation automatically.

During the vertical squareness test set up process, set the orientation of the M unit relative to the rail using the rotational toggle buttons in the software.

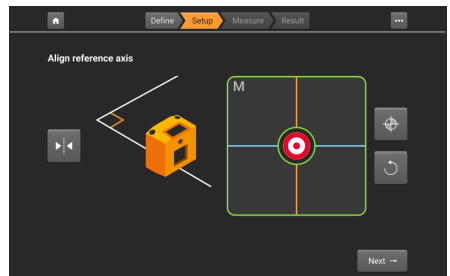
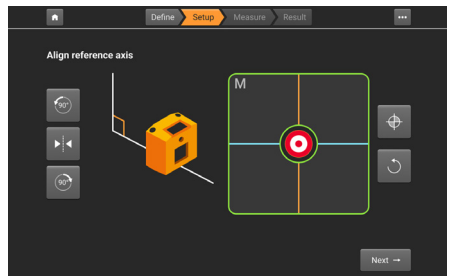
Horizontal squareness	Vertical squareness
In the software, the horizontal squareness measurement mode uses the built-in inclinometers to detect the orientation of the M unit relative to the ground.	In the software, the vertical squareness measurement mode cannot use the built-in inclinometer. Therefore, the M unit orientation is set manually. To set the M unit orientation correctly, based on the plane of the rail you must: Horizontal rail – in the software, set the M unit orientation relative to the ground. Vertical rail – in the software, set the M unit orientation relative to the rail.
	

XK20 analysis





Data fitting methods

End point fit

A straight line is drawn between the first and last end point and subtracts it from the dataset.

Least squares fit

Calculates the best fit straight line through all the data points using the least squares approach, and then removes it.

Zero first

Only the start position is constrained and the deviations are fitted about this point only.

Raw data

No fitting method has been applied and the position value recorded on the PSD is reported at each position.





ISO standards

The International Organisation for Standardisation (ISO) publishes a set of internationally recognised guidelines that ensure a consistent quality of performance. XK20 is compliant to ISO 230 which specifies the use of alignment lasers to measure a range of machine tool geometric features.

Furthermore, XK20 can provide data analysis against the following standards for machine tool building:

- ISO 10791
- ISO 3070

It's important to understand that each ISO standard is specific to a certain kind of machine type. For example ISO 10791:1:2015 is only reference-able against machine tools with Horizontal spindles as their Z axis.

The table below offers further detail:

Standard	Title	Subtitle	Description	Notes
ISO 230-11:2018	Test code for machine tools.	Measuring instruments suitable for machine tool geometry.	This standard documents the characteristics of precision measuring instruments for testing the geometric accuracy of machine tools.	
ISO 10791-1:2015	Test conditions for machining centres.	Part 1: Geometric tests for machines with horizontal spindle (horizontal Z axis).	This standard specifies the geometric tests and tolerances for machining centres with horizontal spindles.	Methods based on measurements of angles (auto-collimators) (ISO 230-1:2012, 12.1.3) shall not be applied as these methods are restricted to measurements of functional surfaces.
BS ISO 10791-2:2023	Test conditions for machining centres.	Geometric tests for machines with vertical spindle (vertical Z-axis).	This standard specifies the geometric tests and tolerances for machining centres with vertical spindles.	Methods based on measurements of angles (auto-collimators) (ISO 230-1:2012, 12.1.3) shall not be applied as these methods are restricted to measurements of functional surfaces.
BS ISO 3070-1:2007	Test conditions for testing the accuracy of boring and milling machines with horizontal spindles.	Machines with fixed column and moveable table.	This standard specifies geometric tests and tolerances for horizontal spindle boring and milling machines that have a fixed column and movable table.	
BS ISO 3070-2:2016	Test conditions for testing the accuracy of boring and milling machines with horizontal spindles.	Machines with moveable column along the X-axis.	This standard specifies geometric tests and tolerances for horizontal spindle boring and milling machines that have a moveable column along the X-axis.	
BS ISO 3070-3:2007	Test conditions for testing the accuracy of boring and milling machines with horizontal spindles.	Machines with moveable column and moveable table.	This standard specifies geometric tests and tolerances for horizontal spindle boring and milling machines that have a moveable column & table.	



ISO standard analysis explained

Global deviation

This is the deviation that occurs across the entire measurement length. Each standard specifies a tolerance for a given measurement length, refer to the relevant ISO standard to find the tolerance that relates to your measurement length for global deviation compliance.

Max / min local deviation

This is the deviation that occurs along a length defined by the specific standard that is selected. For example, in ISO 10791-2 the defined local length is 300 mm. The max / min deviation that is allowed according to ISO 10791-2 is +/- 0.007 mm over any 300 mm section. If the result is outside of the tolerance, it is highlighted in red.

ISO 10791-2 (0.007mm/300mm) ▼		
Deviation	V (mm)	Section (mm)
Global	0.016	0-2000
Max local	0.013	800-1100
Min local	0.003	1600-1900
Deviation	H (mm)	Section (mm)
Global	0.037	0-2000
Max local	0.037	600-1100
Min local	0.002	1600-1900



Renishaw 2012 analysis explained

Once measurements are complete, statistics are displayed in a table.

Max and Min

Max and Min are the maximum and minimum straightness deviations along the measured axes.

Peak-peak

This is the difference between the maximum and minimum straightness values.

Statistic	V	H
Peak-Peak (mm)	0.035	0.016
Standard Deviation (mm)	0.013	0.008
Max (mm)	0.007	0.011
Min (mm)	-0.028	-0.012

These are useful statistics for determining whether an alignment is within assembly tolerances and understanding the size of deviation along an axis.

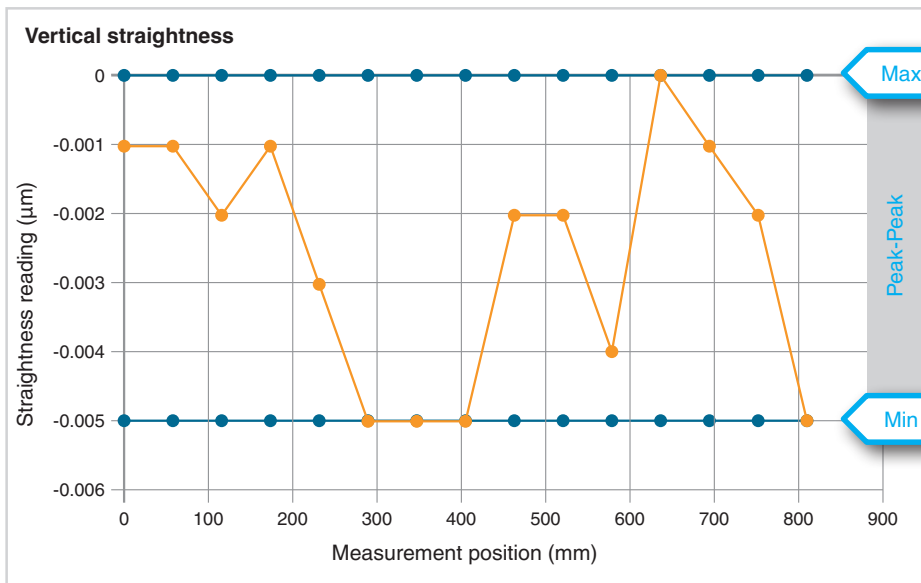

Deviation from the average

Standard deviation (STD)

Standard deviation (STD) represents the amount of deviation/spread from the average. It represents the uniformity of straightness, i.e. the smaller the STD, the better the straightness. Therefore, an axis with a very small STD would be considered very 'straight'.

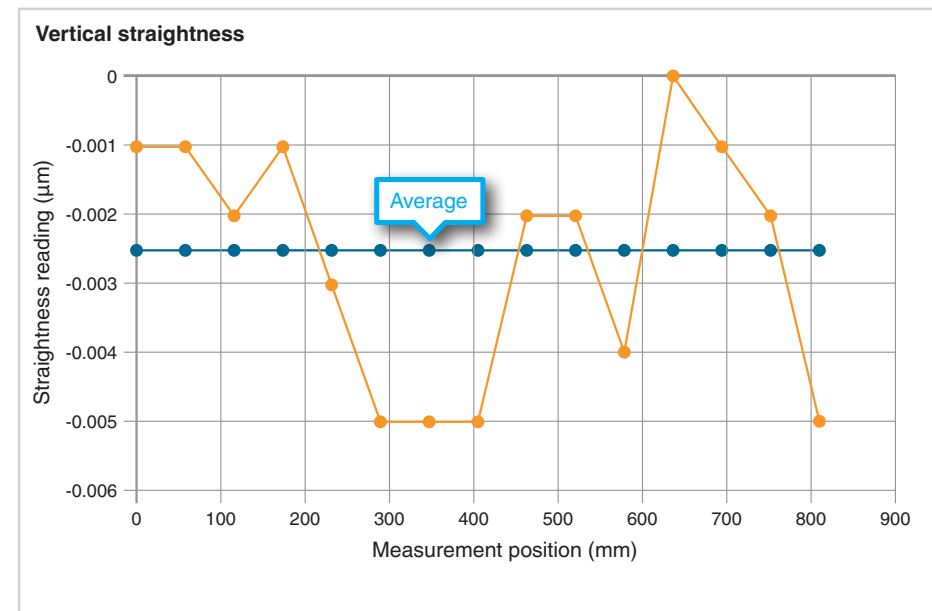



Appendix A

XK20 filtering

Filtering can minimise the effects of small amounts of turbulence across short distances. XK20 filtering uses a median average to smooth sudden fluctuations caused by air turbulence and random vibrations. Ideally, the best solution is to find and minimise the source. Examples of different sources include; doorways, windows or even fans.

This table illustrates the sample period of data:

Filtering level	Sample period
Low	2 seconds
Medium	6 seconds
High	10 seconds

The table illustrates when filtering is recommended:

Distance	Measurement type
Up to 2 m	Short range straightness
2-4 m	Use filtering
4-40 m	Long range straightness

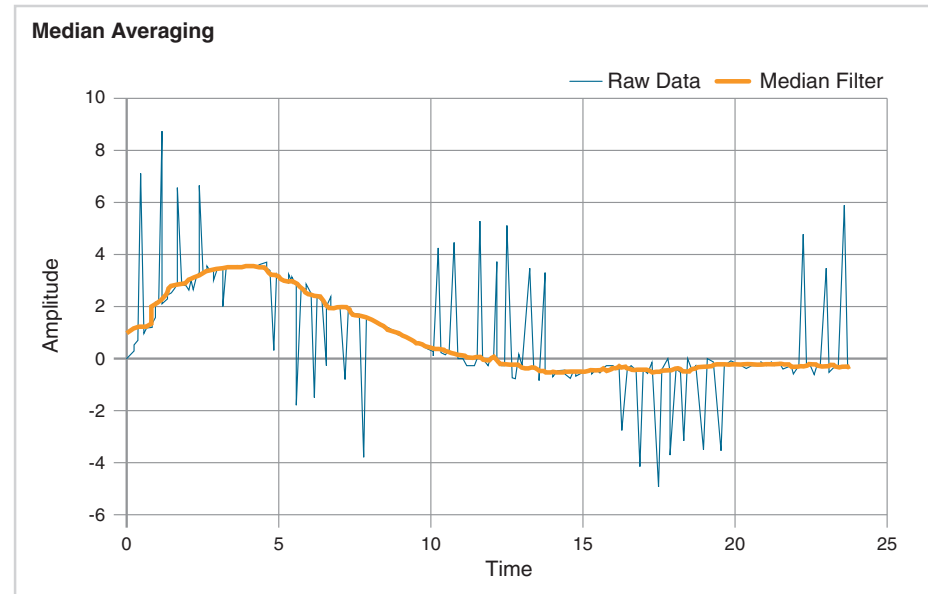

NOTE: Median averaging is part of the reason you may get different straightness results when compared to laser interferometers.



Appendix B

Parallelism – combined horizontal and vertical

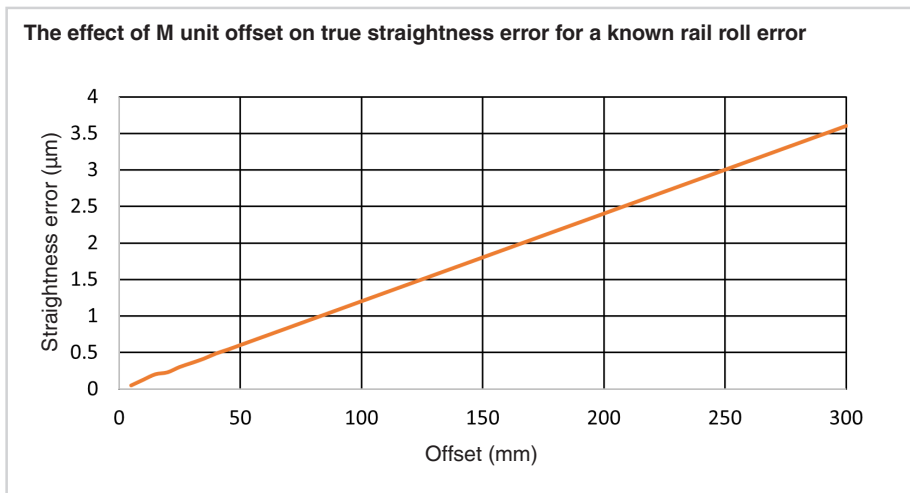

When measuring combined parallelism between two rails, the true straightness error can be affected by the roll of the carriage along the axis of travel. This roll error of the carriage combined with the M unit being offset from the carriage can cause the measured straightness error to appear larger than the true straightness error. This is why it is important to minimise the offset of the M unit from the point of interest.



This is based on an example rail and carriage to have a known roll error of 20Arc seconds.

www.renishaw.com/xk20

 #renishaw

 +44 (0) 1453 524524  uk@renishaw.com

© 2025-2026 Renishaw plc. All rights reserved. This document may not be copied or reproduced in whole or in part, or transferred to any other media or language by any means, without the prior written permission of Renishaw.
RENISHAW® and the probe symbol are registered trade marks of Renishaw plc. Renishaw product names, designations and the mark 'apply innovation' are trade marks of Renishaw plc or its subsidiaries. Other brand, product or company names are trade marks of their respective owners.
Renishaw plc. Registered in England and Wales. Company no: 1106260. Registered office: New Mills, Wotton-under-Edge, Glos, GL12 8JR, UK.

WHILE CONSIDERABLE EFFORT WAS MADE TO VERIFY THE ACCURACY OF THIS DOCUMENT AT PUBLICATION, ALL WARRANTIES, CONDITIONS, REPRESENTATIONS AND LIABILITY, HOWSOEVER ARISING, ARE EXCLUDED TO THE EXTENT PERMITTED BY LAW. RENISHAW RESERVES THE RIGHT TO MAKE CHANGES TO THIS DOCUMENT AND TO THE EQUIPMENT, AND/OR SOFTWARE AND THE SPECIFICATION DESCRIBED HEREIN WITHOUT OBLIGATION TO PROVIDE NOTICE OF SUCH CHANGES.

Part no.: F-9971-9035-03-B
Issued: 04.2026