

MAPS Manual Autojoint Probe Stand

www.renishaw.com

The Renishaw Manual Autojoint Probe Stand (MAPS) is a compact storage rack for up to six autojointed probe combinations.

Mounting can be either direct to the CMM table or work bench using a pillar and base assembly, or to a vertical surface by means of a mounting bracket.

The pillar and base mounting will allow rotational alignment of the stand without marking the mounting surface.

Additional clearance for longer probing combinations (up to 440 mm) can be achieved using pillar extensions. These can be ordered separately.

100 mm pillar extension - Part number M-1051-0147

200 mm pillar extension - Part number M-1051-0148



Maximum length probing combinations		
Standard pillar	100 mm pillar	200 mm pillar
240 mm	340 mm	440 mm

The Renishaw autojoint

The Renishaw autojoint is a system designed for exchanging probe combinations. This is a highly repeatable kinematic joint, one half of which is attached to the probe head, the other half of which is attached to an adaptor, extension bar or probe. The Autojoint is locked or unlocked using a joint key and the connection repeatability eliminates the need for probe redatuming after a change.

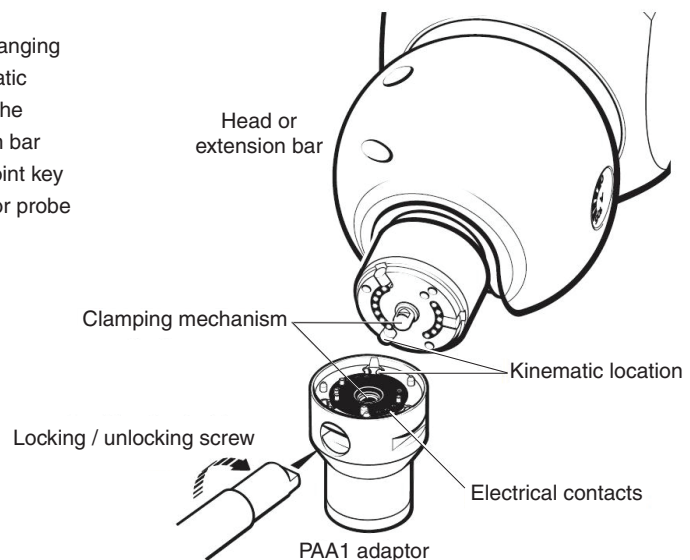

Assembly instructions

Surface mounting the MAPS to the CMM table, or any other suitable surface is achieved by using the mounting pillar and base and by carrying out the following procedure;

1. Secure the base to the mounting surface using a suitable bolt (not supplied)
2. Locate and screw the threaded end of the mounting pillar securely into the sliding nut located on the underside of the storage rack
3. Locate the assembly into the base, adjust the position to suit and secure with the three grub screws using the key supplied

Wall mounting the MAPS is achieved using the mounting bracket and by carrying out the following procedure;

1. Secure the mounting bracket to the wall or any other suitable vertical surface via the two bolt holes
2. Fit the storage rack onto the mounting bracket with the mounting bolt supplied

Loading the storage ports

Each storage port is numbered (1 to 6) so that the probe tip data for each probing combination can be easily selected.

To load each port, simply rotate the autojoint until the key slot faces the back of the port then locate the top face of the autojoint under the storage rack lid and insert.

NOTE: Do not use excessive force as this may cause damage to the autojoint mounting.

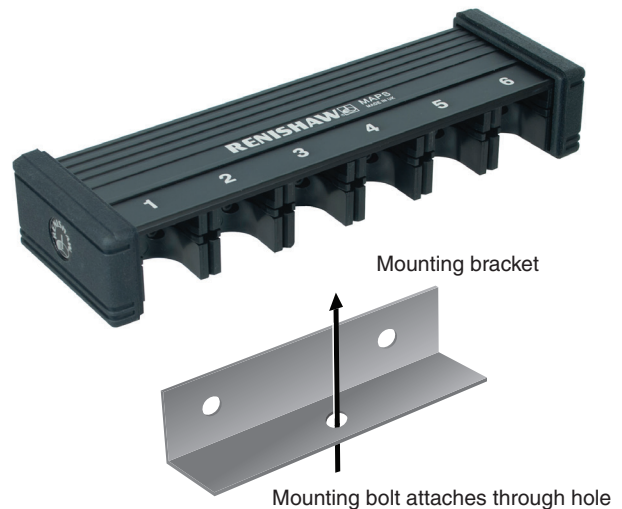

For worldwide contact details, please visit our
main web site at www.renishaw.com/contact

RENISHAW HAS MADE CONSIDERABLE EFFORTS TO ENSURE THE CONTENT OF THIS DOCUMENT IS CORRECT AT THE DATE OF PUBLICATION BUT MAKES NO WARRANTIES OR REPRESENTATIONS REGARDING THE CONTENT. RENISHAW EXCLUDES LIABILITY, HOWSOEVER ARISING, FOR ANY INACCURACIES IN THIS DOCUMENT.



H - 1000 - 5300 - 03