

# SFM-E1

## Surface finish probe module

### Enhanced access and inspection capability for integrated surface finish measurement

The SFP2 system consists of a probe and a range of SFM modules which have been designed to suit the demands of specific parts and features encountered in a precision manufacturing environment. The probe and modules can be automatically interchanged with all other REVO® probe options, providing the flexibility to easily select the optimum tool to inspect a wide range of features.

Each SFM module is its own miniature measuring device, incorporating Renishaw's proprietary encoder system to transduce the motion of the stylus tip.



### Features

The E-series of modules use dual skids with a central stylus. This makes them ideal for short scans on small to medium sized bores which may be deep within the workpiece.

### Typical applications

Automatic transmission valve bodies, valve seats, minimum feature access (mm): Ø9 × 52 (max. depth).

### Specification

Diamond tip radius (µm)		2 or 5
Surface finish measurement range (µm)	2 µm modules	6.3 to 0.05 Ra
	5 µm modules	6.3 to 0.10 Ra
Typical surface finish accuracy (of nominal Ra) *		±(10% + 20 nm)
Skid / stylus arrangement		Stylus central to dual skids
Skid material		DLC coated stainless steel
Nominal stylus tip protrusion beyond skid (mm)		0.6
Minimum feature access (mm)		Ø9 × 52 (maximum depth)
Skid length / radius (mm)		4.6 / 40
Skid width / radius (mm)		5.0 (total) / n/a
Skid contact force (N)		0.15
Stylus contact force (N)		0.003
SFM / SFH knuckle adjustment range		±90°
Weight (g)		12
Resolution (nm)		1
Measurement speed (mm/s)		Up to 1
Stylus holder compatibility		SFH-1 only
Lateral scanning capability		No

\* Accuracy values are dependent upon a number of system variables. These include the machine size and configuration, scan orientation, condition of stylus tip, part fixturing system and environmental noise.

All dimensions in mm.

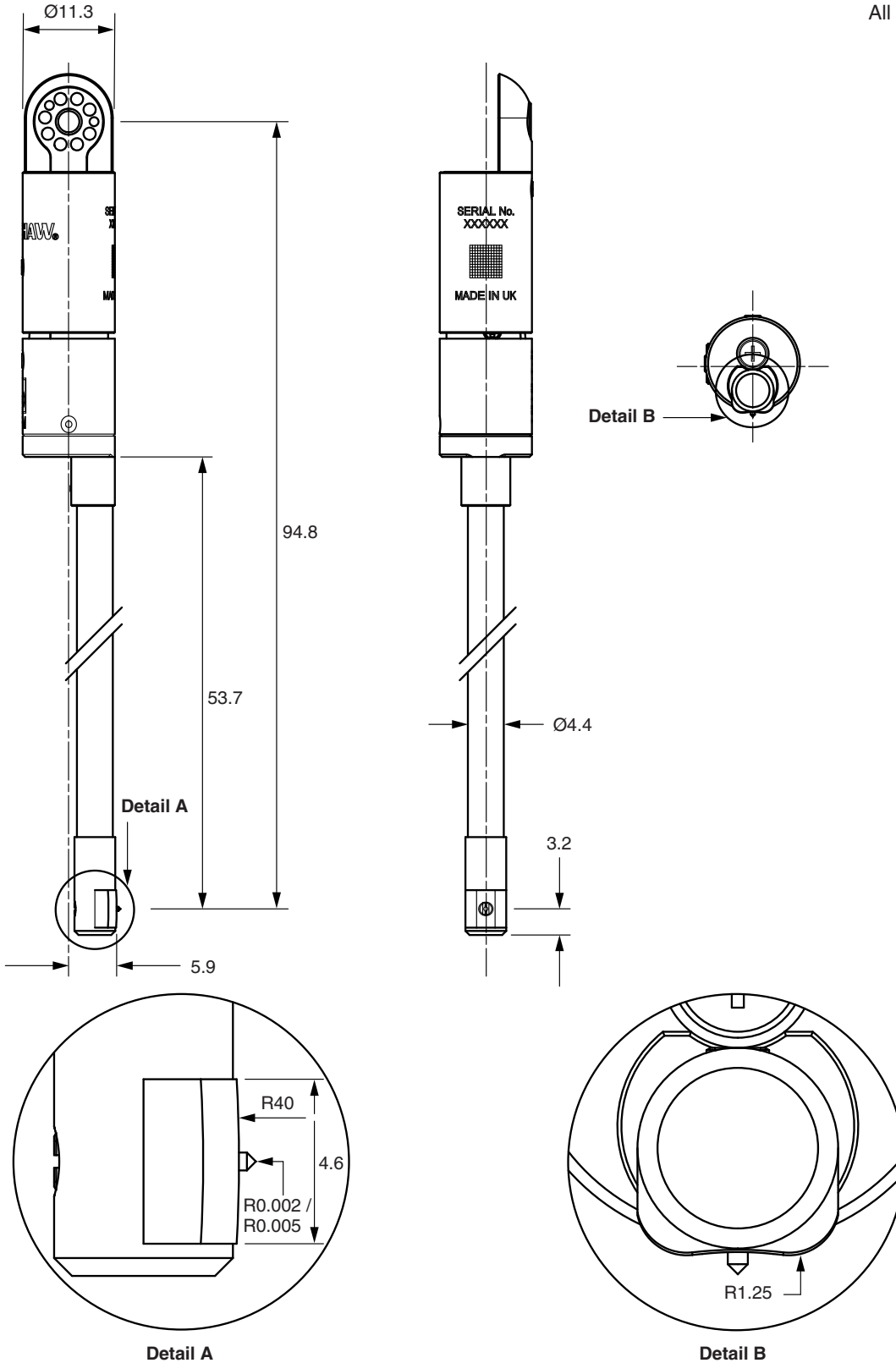

[www.renishaw.com/SFP2](http://www.renishaw.com/SFP2)

 #renishaw

+44 (0) 1453 524524

 [uk@renishaw.com](mailto:uk@renishaw.com)

© 2018–2021 Renishaw plc. All rights reserved. RENISHAW® and the probe symbol are registered trade marks of Renishaw plc. Renishaw product names, designations and the mark 'apply innovation' are trade marks of Renishaw plc or its subsidiaries. Other brand, product or company names are trade marks of their respective owners. Renishaw plc. Registered in England and Wales. Company no: 1106260. Registered office: New Mills, Wotton-under-Edge, Glos, GL12 8JR, UK. WHILE CONSIDERABLE EFFORT WAS MADE TO VERIFY THE ACCURACY OF THIS DOCUMENT AT PUBLICATION, ALL WARRANTIES, CONDITIONS, REPRESENTATIONS AND LIABILITY, HOWSOEVER ARISING, ARE EXCLUDED TO THE EXTENT PERMITTED BY LAW.

Part no.: H-1000-2310-05-A  
 Issued: 10.2021