

# Basic command set for indexing heads



© 2002 Renishaw. All rights reserved.

Renishaw® is a registered trademark of Renishaw plc.

This document may not be copied or reproduced in whole or in part, or transferred to any other media or language, by any means, without the prior written permission of Renishaw.

The publication of material within this document does not imply freedom from the patent rights of Renishaw plc.

### **Disclaimer**

Considerable effort has been made to ensure that the contents of this document are free from inaccuracies and omissions. However, Renishaw makes no warranties with respect to the contents of this document and specifically disclaims any implied warranties. Renishaw reserves the right to make changes to this document and to the product described herein without obligation to notify any person of such changes.

### **Trademarks**

All brand names and product names used in this document are trade names, service marks, trademarks, or registered trademarks of their respective owners.

### **Care of equipment**

Renishaw probes and associated systems are precision tools used for obtaining precise measurements and must therefore be treated with care.

### **Changes to equipment**

Renishaw reserves the right to improve, change or modify its hardware or software without incurring any obligations to make changes to Renishaw equipment previously sold.

### **Warranty**

Renishaw plc warrants its equipment for a limited period (as set out in our Standard terms and conditions of sale) provided that it is installed exactly as defined in associated Renishaw documentation.

Prior consent must be obtained from Renishaw if non-Renishaw equipment (e.g. interfaces and/or cabling) is to be used or substituted for Renishaw equipment.

Failure to comply with this will invalidate the Renishaw warranty. Claims under warranty must be made from authorised Service Centres only, which may be advised by the supplier or distributor.

### **Patents**

Features of the various products shown in this programmer's guide, and features of similar products, are the subject of the following patents and patent applications:

EP 0068899	JP 1556462	US 4462162	JP 2,647,881	TW UM-099300
EP 0142373	JP 2,098,080	US 4651405	JP 501,776/1994	
EP 0243766	JP 2,510,804	US 4813151	JP 503,652/1994	
EP 0293036	JP 2,545,082	US 4916339	JP 507,918/1997	
EP 0388993		US 5,323,540	JP 508,476/1993	
EP 0501710		US 5,327,657		
EP 0544854		US 5,339,535		
EP 0740768		US 5,345,689		
EP 0750171		US 5,404,649		
EP 279828 B		US 5,505,005		
EP 548328 B		US 5,755,038		
EP 566719 B				

Renishaw part no: H-1000-5075-04-B

Issued: 02 2002

**Renishaw plc**

**Basic command set  
for indexing heads**

**Programmer's guide**



<b>Contents</b>		<b>Page</b>
1.0	Introduction	3
<b>RS232-C</b>		
2.0	Definition of terms	4
3.0	Serial data transmission	5
4.0	Transmission from MMC to PHC10-2	6
5.0	Transmission from PHC10-2 to MMC	8
6.0	Flowchart descriptions	11
	Table 1 - RS232 communication codes	13
	Flowcharts 1 - 10	14 - 24
<b>IEEE488</b>		
7.0	Definition of terms	25
8.0	Parallel data transmission	27
9.0	Transmission from MMC to PHC10-2	28
10.0	Transmission from PHC10-2 to MMC	30
11.0	Flowchart descriptions	33
	Table 2 - IEEE488 communication codes	35
	Flowcharts 11 - 18	37 - 45
<b>Appendix</b>		
	Obstruct error codes	46

## 1.0 Introduction

This guide provides programming information for the RS232 and IEEE488 versions of the PHC10-2 controller (note that the appropriate version of the controller must be ordered for each type of system). The programming flowcharts given are suitable for all the PH10 series of motorised probe heads.

- 1.1 The PHC10-2 system is designed for interactive communication with a computer, using standard ASCII code. This document describes the codes and techniques used to control a PH10 probe head from a measuring machine's control computer, using an RS232 serial data link or an IEEE488 parallel instrumentation bus.
- 1.2 In addition to the list of control codes and their uses, two sets of flowcharts have been included for each type of communications system. One set describes the action of the PH10 in response to various stimuli as far as communication with the computer is concerned; the other set of charts is intended to aid the computer programmer in building a program to operate the PH10 system. The latter set of flowcharts is given as a guide only to allow a simple system to be designed. It is anticipated that the system will subsequently be customised to the user's own requirements.
- 1.3 Included in the flowcharts is an outline program for using the HCU1 hand control unit to "teach" the measuring machine computer a sequence of movements for use in future automatic measurement cycles.

## RS232-C

### 2.0 Definition of terms

- 2.1 "PH10" is the probe head which orientates the probe itself in two axes.
- 2.2 "PHC10-2" is the electronic controller which controls the PH10 head and communicates with the measuring machine control computer.
- 2.3 "HCU1" is the optional hand-held control/display module used by an operator for controlling the PH10 when the PHC10-2 system is in manual mode. It also has a means of transmitting to the measuring machine control computer.
- 2.4 "MMC" is the measuring machine computer used for controlling the PHC10-2 system and the measuring machine itself.
- 2.5 "STATUS" is the status word transmitted by the PHC10-2 to define the current state of the PHC10-2 system. It includes HCU1 status (code H); PH10 error codes, if any (F, O and D); PHC10-2 status (M); PH10 position (A(POSITION)B(POSITION)(CR)). In the absence of a PH10 the status word will consist only of J(CR).
- 2.6 "(POSITION)" refers to the angular axis data transmitted between the PHC10-2 and the MMC. The positions are composed of ASCII numerals, + and - signs and "decimal point" ("period" or "full-stop"; ASCII code 2E hexadecimal, 056 octal).
- 2.7 "XON State" is the period during which data may be sent from the MMC to the PHC10-2 (see section 5.2.1).
- 2.8 "XOFF State" is the period during which data must not be sent to the PHC10-2 (see section 5.2.2).
- 2.9 "START" is the electrical power-up of the PHC10-2 system. Either full status or J(CR) will be transmitted to the MMC at the end of the power-up routine.
- 2.10 "RESTART" refers to the PH10 being refitted to the system whilst the PHC10-2 is powered up. STATUS will be transmitted to the MMC when the system becomes active.
- 2.11 "MOVE COMPLETE" state is the condition in which the PHC10-2 is in stand-by mode, not updating the PH10 position. The MOVE COMPLETE state is ended by the start of repositioning the PH10, either in auto or manual mode, or whilst unlocking the PH10 in an emergency. The PH10 probe is enabled during the MOVE COMPLETE state, but not while the PH10 position is being updated.
- 2.12 "PICS" refers to the Product inter-connection system incorporated into the PHC10-2 and other Renishaw interfaces and controls. The PICS signals are detailed in the PH10 Series Installation Guide (Part Number H-1000-5071) and only the "STOP" (system problem) is referred to in this document.

### 3.0 Serial data transmission

- 3.1 Data is transmitted between the PHC10-2 and the MMC by means of an RS232-C serial link, using standard ASCII code. Data from the PHC10-2 to the MMC has bit 8 set to zero; for data to the PHC10-2 from the MMC, bit 8 is "don't care". The transmission link should be Full Duplex.
- 3.2 Data transmission is in the format 1 START BIT, 8 DATA BITS, 2 STOP BITS, from the PHC10-2; 1 START BIT, 8 DATA BITS, 1 or 2 STOP BITS to the PHC10-2. No parity is transmitted or accepted by the PHC10-2.
- 3.3 The letter codes used are all upper case (capitals). The codes are detailed in section 4, but are summarised in Table 1 for convenience.
- 3.4 When the PHC10-2 is powered up, it is possible that one or two spurious characters will be sent to the computer. These unpredictable characters will be followed by STATUS, from half to several seconds later. Spurious characters may also be transmitted on power down. They will not occur on RESTART.
- 3.5 The "request to send" line is set active HI after the PHC10-2 has completed its initialisation routine following START or RESTART. It will then stay HI until a RESTART or power down.
- 3.6 The "clear to send" line must be set active by the MMC to allow transmission from the PHC10-2.

#### 4.0 Transmission from MMC to PHC10-2

- 4.1 All transmissions from the MMC to the PHC10-2 must be terminated by a carriage return character (CR). If a line feed (LF) is sent, it will be ignored by the PHC10-2.
- 4.2 No transmission may take place from the MMC to the PHC10-2 during the XOFF State.
- 4.3 Data to the PHC10-2 falls into two categories; control data and positional data. The PHC10-2 will acknowledge all complete transmissions to it directly or indirectly.
- 4.4 Control characters to the PHC10-2 consist of a single character followed by (CR). Where the response from the PHC10-2 is expected to consist of STATUS, the MMC must wait for the terminating (CR) before sending any other data to the PHC10-2. Failure to wait for end of STATUS may result in confusion, as the response from the PHC10-2 to some further communication from the MMC will interrupt the STATUS transmission and thus abort it.
- 4.4.1 **M (CR)** sets the PHC10-2 to manual mode. This code is only valid in auto mode, when it will be acknowledged by the PHC10-2 sending STATUS to the MMC. If M is received in manual mode, then the PHC10-2 will transmit C (see section 5.3.2).
- 4.4.2 **N (CR)** sets the PHC10-2 to auto mode. This code is only valid in manual mode, when it will be acknowledged by the PHC10-2 sending STATUS to the MMC. If N is received in auto mode then the PHC10-2 will transmit C (see section 5.3.2).
- 4.4.3 **S (CR)** requests the PHC10-2 to send STATUS to the MMC. It will be acknowledged by the PHC10-2 sending STATUS. S is valid during all XON states.
- 4.4.4 **U (CR)** will cause the PHC10-2 to update the PH10 position. This code is only valid in auto mode, when the position of the PH10 will be set up from the last A and B positions sent by the MMC. The last known manual position is ignored and lost by the use of U. XOFF will be transmitted before the start of the PH10 move. Following update of the PH10, the PHC10-2 will transmit STATUS. If U is received in manual mode then the PHC10-2 will transmit C (see section 5.3.2).
- 4.5 Positional data may be sent to the PHC10-2 during any XON state, although it is pointless when the PH10 is disconnected.
- 4.5.1 All angles must be precise multiples of 7.5°, with no rounding of data. The decimal place (either .0 or .5) must always be included. Angle 0.0 is always positive, and only B axis may contain negative data. In the absence of a sign character the PHC10-2 assumes positive data is intended.
- 4.5.2 Valid angles are as follows:
- A axis: +0.0 to +105.0° in 7.5° increments.  
B axis: -180.0 to +180.0° in 7.5° increments.
- 4.5.3 (POSITION) from the MMC to the PHC10-2 may be leading zero suppressed or non-suppressed; 0.0, 00.0 and 000.0 are equally correct.
- 4.5.4 The format for A axis data is A(POSITION)(CR); B axis format is B(POSITION)(CR). After the initial transmission of A and B axis data to the PHC10-2, A(CR) and B(CR) are also valid as the PHC10-2 stores the last A and B positions it received. However, A(CR) and B(CR) serve no real purpose.



- 4.5.5 If one axis position is to be repeated during the next PH10 move, that axis does not have to be sent to the PHC10-2 again, although it may be advisable to do so. For example, if the last auto mode position was A0.0, B7.5 and the next is A15.0, B7.5, then only A15.0(CR) need be transmitted.
- 4.5.6 During START or RESTART, all PH10 data (including the auto mode positions previously set) are lost.
- 4.5.7 If the PHC10-2 receives a valid angle from the MMC, it will transmit V to acknowledge valid data. If the angle is invalid then I will be transmitted (see sections 5.3.3 and 5.3.4).
- 4.5.8 Examples of valid angular data are A+0.0(CR), B0.0(CR), B-7.5(CR), A90.0(CR), B+007.5(CR).
- 4.5.9 Examples of invalid angular data are A-7.5(CR), B-0.0(CR), A+150.0(CR), B-187.5(CR), A5.0(CR), B7.2(CR)
- 4.5.10 The PHC10-2 sets no limit on the number of times each axis position is transmitted to it. The only proviso is that nothing may be sent to the PCH10-2 until either I or V has been transmitted to the MMC.

## 5.0 Transmission from PHC10-2 to MMC

5.1 Transmission from the PHC10-2 is of three main types; control characters, transmission acknowledgement and system status. A code is also generated by the HCU1 under certain conditions.

5.2 Control codes from the PHC10-2 are not followed by (CR). They are used to control communication from the MMC to the PHC10-2.

5.2.1 **(XON)** is the ASCII code DC1 (hexadecimal code 11, octal code 021). (XON) is transmitted to the MMC to indicate that the PHC10-2 is able to receive and act upon data from the MMC. The system condition is referred to as the XON state, and is terminated by the transmission of (XOFF) to the MMC. The XON state can only occur when the PHC10-2 system is in a MOVE COMPLETE state (i.e. the PH10 position is not being changed).

5.2.2 **(XOFF)** is the ASCII code DC3 (hexadecimal code 13, octal code 023). It is transmitted to the MMC to indicate that the PHC10-2 system cannot accept or act upon any transmission from the MMC. The system condition is referred to as the XOFF state and is terminated by (XON). Any data transmitted to the PHC10-2 during this period of "deafness" is lost. (XOFF) is sent:

- a) in conjunction with various error codes when the PHC10-2 serial receiver is turned off immediately upon transmission of (XOFF):
- b) preceding any movement of the PH10, either in auto or manual mode, when a delay is incorporated following the actual transmission of (XOFF). This delay allows any data already in transmission to be received and, if required, acted upon by the PHC10-2. The delay is sufficient to allow one character to reach the PHC10-2 after it has sent (XOFF), assuming the slowest transmission rate.

An (XOFF) state is in force during START/RESTART, although (XOFF) is not actually transmitted. If a string of data transmitted from the MMC is interrupted by (XOFF), that data is not corrupted or lost provided that the data is not actually transmitted during an (XOFF) state. Transmission of the string may be resumed as soon as (XON) is received.

5.3 Certain characters are sent to the MMC to indicate the validity, or otherwise, of data received. Each error code is preceded by (XOFF), but the "valid" acknowledgements are not. All codes are followed by (CR) and by (LF) if LF protocol has been selected on the PHC10-2 rear switches. Where an (XOFF) state is generated, the MMC will backtrack to the last known transmission, as no delay is incorporated before turning off the serial interface.

5.3.1 **E** is transmitted by the PHC10-2 to indicate that the format of serial data transmission is incorrect. The format transmitted to the MMC is (XOFF)E(CR), followed after an interval by (XON). Transmission errors include overrun, framing errors and break characters. The most probable reason for E being transmitted is response to the MMC sending data whilst the PHC10-2 is checking the last axis data received. Always wait for V or I before sending further data.

5.3.2 **C** is transmitted to the MMC in response to an invalid control code followed by (CR), or (CR) without a control code being received by the PHC10-2. "Invalid code" is defined as being either a totally unused ASCII code, e.g. "Z", or a code which is not applicable to the current PHC10-2 mode, e.g. the MMC sends U(CR) in manual mode. The transmitted format is (XOFF)C(CR), followed after an interval by (XON). The control code buffer is reset in the PHC10-2 in readiness for the next control code.

- 
- 5.3.3 **I** is transmitted to the MMC to show that the axis data received by the PHC10-2 is not a valid angle, or that the format is wrong (e.g. too many characters). The format transmitted is (XOFF) I (CR) followed by (XON) after an interval.
- 5.3.4 **V** is transmitted to the MMC to indicate that the A or B axis data received by the PHC10-2 was valid. The format transmitted is V(CR); (XOFF) is not associated with this code.
- 5.4 STATUS from the PHC10-2 to the MMC can be of two types: full status, used under normal error and non-error conditions; and abbreviated status, used for emergency-action errors. STATUS is terminated by (CR) and also by (LF) if LF protocol has been selected on the PHC10-2 rear switches. Full status is transmitted after START/RESTART, in response to a status request from the MMC (code S), on successful change from manual to auto mode and vice versa (including removal of the HCU1 in manual mode) and on completion of an auto mode move of the PH10. It is transmitted in the form HOFDMA(POSITION) B(POSITION)(CR), where any or all of HOFDM may be absent. The sequential order of HOFDM may not always be consistent. The error status of the PHC10-2 is reset at the start of either an auto or manual PH10 move, but is never carried over to the next move.
- 5.4.1 **H** is the code prefixed to the PH10 positional data to indicate that the HCU1 is not connected. Absence of H in the status word implies that the HCU1 is connected. Manual mode cannot be selected if H is present. The system reverts to auto mode if the HCU1 is removed while the system is in manual mode, and STATUS is automatically transmitted to the MMC when this occurs. Presence of the HCU1 is checked during (XON) states, except when the PH10 is not fitted. H and M are mutually exclusive.
- 5.4.2 **M** is used to indicate that the PHC10-2 system is in manual mode. Absence of M implies that the system is auto mode. The system powers up in manual mode if the HCU1 is connected, otherwise auto mode is selected. Manual mode cannot be selected in the absence of the HCU1, so that M and H are mutually exclusive. Auto/manual condition of the PHC10-2 is monitored during (XON) states except when the PH10 is disconnected. Change of mode results in STATUS being transmitted to the MMC.
- 5.4.3 **D** indicates that the PH10 has a datum error due to not being seated correctly. Accuracy of PH10 positioning is not guaranteed when this error code is present. Absence of the code implies no datum error. A datum error arising during a MOVE COMPLETE state is translated as an emergency overload error and results in code X being transmitted (see section 5.6).
- 5.4.4 **O** indicates that the PH10 has an obstruction error. This implies that the PH10 failed to complete a move in a predetermined time, and is checked at appropriate points during PH10 move sequences. Absence of the code implies no obstruction error. The error condition is caused by the PH10 encountering an external obstruction during a move, or by an obstruction within the PH10 itself (e.g. locking motor jammed). The PH10 position is not guaranteed in this error state. To prevent potential damage to the PH10 it is recommended that the measuring machine is not moved while the PH10 position is being updated. The probe fitted to the PH10 is not enabled during a PH10 move.
- 5.4.5 **F** indicates that the PH10 was unlocked in a MOVE COMPLETE state due to excessive force applied to the PH10, resulting in an overload error. An example of this error is if the PH10 collides with a workpiece while the PH10 is locked up. F is the code used in STATUS to indicate that X has been transmitted to the MMC (see section 5.6). Absence of code F implies that the PH10 is locked up.

- 5.4.6 The main part of STATUS comprises the A and B axis positions. They are transmitted in the form A(POSITION)B(POSITION)(CR), and this expression is the minimum full status word which will be transmitted. It implies auto mode with the HCU1 connected and no PH10 errors. (POSITION) as defined in sections 4.5.1 to 4.5.3. Angles are always leading zero suppressed and no positive sign is transmitted to the MMC.
- 5.5 **J** is an abbreviated status code sent to the MMC to show that the PH10 is not connected to the system. The full format is J(CR). It is first transmitted when the PH10 is removed, and in response to a status request from the MMC (code S). Full status will not be sent if the PH10 is not fitted. If full status is being transmitted when the PH10 is removed, it will be aborted, resulting in, for example, A90.0B3J(CR). Presence of the PH10 is checked periodically during (XON) states including when the PH10 is not fitted. Refitting the PH10 will result in the PHC10-2 system restarting as if from power-up. The MMC should check for J continually, preferably on an "interrupt" basis, and shut down the measuring machine immediately J is detected. Do not wait for (CR). The PICS STOP signal is activated by the PHC10-2 and is held active until the PH10 is reconnected.
- 5.6 **X** is an abbreviated status code sent to the MMC to show that the PH10 has lost its datum while in a MOVE COMPLETE state and has subsequently been unlocked. X is classed as an excess force or overload error, and is transmitted in the format X(CR)(XOFF) followed after an interval by (XON). If the full status is being transmitted at the time it will be aborted, resulting in, for example A90.0B3X(CR)(XOFF). Although (XOFF) is sent after (CR), the serial interface is actually disabled when X is transmitted. The overload condition is checked for in the locked up state of the PH10, provided that no datum error is present already. If the system has a datum error, the overload facility is disabled. The probable cause of an overload is the PH10 colliding with the workpiece, etc. The MMC should continually check for X, preferably on an "interrupt" basis, and inhibit movement of the measuring machine immediately. Do not wait for (CR). It is recommended not to move the measuring machine if the PHC10-2 system has an error, as the overload monitor is disabled and cannot protect the PH10. X is not sent in response to a status request; F is used in full STATUS transmission instead (see section 5.4.5). The probe fitted to the PH10 is enabled in this condition, except during the unlock sequence. The PH10 may be locked up again in auto by transmitting U to the PHC10-2 or by pressing A or B position keys on the HCU1 in manual. The PICS STOP signal is activated by the PHC10-2 and is held until the start of the recovery move.
- 5.7 **T** is transmitted from the PHC10-2 to the MMC when the operator pushes the "T" key on the HCU1. The "T" key can only be operated when the PHC10-2 is in manual mode and MOVE COMPETE state, otherwise it is disabled. The format transmitted is T(CR). It has no significance other than that attributed to it by the MMC program.

---

## 6.0 Flowchart descriptions

- 6.1 Flowcharts 1 to 4 describe the action of the PHC10-2 in response to various stimuli as far as communication to and from the MMC is concerned.
- 6.1.1 Flowchart 1 indicates that a status request from the MMC is valid (code S), resulting in a response from the PHC10-2 of J(CR). The MMC may also send A(POSITION)(CR) and B(POSITION)(CR), but these serve no useful purpose, since all data is lost as soon as the PH10 is refitted. A and B data to the PHC10-2 are acknowledged with I or V in the usual way. All other communications from the MMC elicit the response C(CR).
- 6.1.2 Flowchart 2 shows that the PHC10-2 reacts to the emergency condition of the PH10 colliding with an obstruction that causes it to unlock. The emergency should be acted on by the MMC immediately the code X is received by it, without waiting for the (CR). The MMC may switch the PHC10-2 to either auto or manual as desired.
- 6.1.3 Flowchart 3 describes the system status checks when the PHC10-2 is idling in the MOVE COMPLETE state. The probe fitted to the PH10 is enabled during this period and disabled during a PH10 move. If the PHC10-2 system is in an XOFF state then XON will be sent immediately following the status report check. Auto/manual mode can be changed either by the HCU1 being removed (but not when it is replaced) or by MMC command. Either results in STATUS being transmitted. Response to the "T" is entirely in the hands of the MMC program; for an example see flowchart 6.
- 6.1.4 Flowchart 4 shows the response of the PHC10-2 system to each character transmitted by the MMC. The overrun/framing error check deals also with break conditions of the serial link and with uncontrolled bursts of characters. Each new control code from the MMC is held in the buffer until receipt of (CR), or a second character when the validity, or otherwise, of the control character is checked. The only codes which can be followed by anything other than (CR) are the A and B axis codes; these are checked for too many characters being received by the PHC10-2. The validity of the characters being received after A or B is not checked until after (CR), when the angle is verified. Where flags are set for later action, that action is checked for during the stand-by routine and dealt with accordingly. If (XOFF) is transmitted during the response shown in flowchart 4, (XON) will be transmitted during stand-by. The (LF) character is always ignored by the PHC10-2.
- 6.2 Flowcharts 5 to 10 are provided to give help in producing a simple computer program, suitable for operating the PHC10-2 system. It is anticipated that this program will be used only as a guide, useful in familiarising the programmer with the PHC10-2 system before customising the system to his own requirements. The flowcharts refer to a "data file". This is a hypothetical file containing positional data used for moving the measuring machine and PH10 combination during automatic measuring cycles. The programs are shown on flowcharts 5 and 6. Subroutines connected with the programs are shown on flowcharts 7 to 10.

- 6.2.1 Flowchart 5 shows the START/RESTART and auto mode programs. It is advisable to have the MMC switched on and running before powering up the PHC10-2 system or refitting the PH10. Immediately after START/RESTART begins, the PHC10-2 system is in an XOFF state and the "request-to-send" line will be "off" (LO). (XON) is transmitted following the first STATUS transmission. Various system conditions are assumed to be of interest to the machine operator and these are suggested on the flowchart as ALERT and NOTIFY, distinguishing between error and non-error conditions. Relevant data will be displayed on the MMC console. Auto mode shows the system being used in an automatic measuring "sequence" using the hypothetical "data file" to provide various movement coordinates. Because the methods of performing the measurement will vary between types of machine, no program outline is given for this function.
- 6.2.2 Flowchart 6 gives an example of the use of the manual mode of the PHC10-2 system in operation. It is assumed that the MMC has to somehow learn where to drive the PH10/measuring machine combination in order to perform certain measurements in automatic sequence. This flowchart shows a method for implementing this "teaching" mode, the principle being that the operator moves the probe into a suitable position using the HCU1 and machine control, and then uses the "T" key on the HCU1 to induce the MMC to remember the coordinates of the machine and probe. As the time available for acquisition of PH10 status, and for the MMC to perform calculations on it, is approximately 900ms after receipt of T(CR) by the MMC, it may be desirable to set the HCU1 system into auto mode for a while to prevent the operator from performing further moves. The HCU1 has an indicator to show the operator whether auto or manual mode is selected. Where slow baud rates are anticipated it is also advisable to make use of the auto mode to allow a breathing space for the MMC. The PHC10-2 does not check for HCU1 keys while it is sending STATUS.
- 6.2.3 Flowchart 7 shows a subroutine for dealing with data from the PHC10-2. This input routine should be run under interrupt in order to deal with unsolicited data from the PHC10-2, such as X and J. X and J should be dealt with immediately, without waiting for the following (CR). (XON) and (XOFF) should merely set a flag which may be used in the output routine (see Flowchart 8) to indicate whether data may or may not be sent to the PHC10-2. Although no method of dealing with error codes E and C is given, these should ideally be dealt with in this subroutine or, failing this, in the calling program.
- 6.2.4 Flowchart 8 is an illustration of the use of the XON/XOFF flag in deciding when data may be sent to the PHC10-2. It assumes that data is transmitted as a string, although the string may only consist of two characters.
- 6.2.5 Flowchart 9 shows a way of sending each new axis position to the PHC10-2. Although the flowchart suggests sending the position only once more if an "invalid" code I is returned, the data may be sent as often as desired. More than one or two repeats will, however, indicate a serious failure in the serial transmission system.
- 6.2.6 Flowchart 10 shows a basic subroutine for receiving STATUS from the PHC10-2. Positional data is saved in buffers for use in the calling programs. As with the other subroutines and programs, no specific action is recommended to deal with error codes, as the outlines given are for simple programs only.

<b>TABLE 1 - RS232 COMMUNICATION CODES</b>			
<b>CODE</b>	<b>FUNCTION</b>	<b>FROM - TO</b>	<b>FORMAT</b>
A	Prefix for AXIS-A data	MMC - PHC10-2 PHC10-2 - MMC	A(POSITION)(CR) OR A(CR) A(POSITION)B(POSITION) (CR)
B	Prefix for AXIS-B data	MMC - PHC10-2	B(POSITION)(CR) OR B(CR)
C	Invalid control character	PHC10-2 - MMC	(XOFF)C(CR) ... (XON)
D	PH10 datum error	PHC10-2 - MMC	DA(POSITION)B(POSITION)(CR)
E	Transmission error	PHC10-2 - MMC	(XOFF)E(CR) ... (XON)
F	PH10 Overload error	PHC10-2 - MMC	FDA(POSITION)B(POSITION)(CR)
G	Reserved		
H	HCU1 disconnected	PHC10-2 - MMC	HA(POSITION)B(POSITION)(CR)
I	Invalid A or B AXIS data	PHC10-2 - MMC	(XOFF)I(CR) ... (XON)
J	PH10 disconnected	PHC10-2 - MMC	J(CR)
K	Reserved		
L	Reserved		
M	PHC10-2 manual mode	PHC10-2 - MMC MMC - PHC10-2	MA(POSITION)B(POSITION)(CR) M(CR)
N	PHC10-2 auto mode	MMC - PHC10-2	N(CR)
O	PH10 Obstruct error	PHC10-2 - MMC	ODA(POSITION)B(POSITION)(CR)
P	Reserved		
Q	Reserved		
R	Reserved		
S	Status request	MMC - PHC10-2	S(CR)
T	HCU1 'T' key	PHC10-2 - MMC	T(CR)
U	Update PH10 position	MMC - PHC10-2	U(CR)
V	Valid A or B AXIS data	PHC10-2 - MMC	V(CR)
W	Reserved		
X	Excess force/Overload error	PHC10-2 - MMC	X(CR)(XOFF) ... (XON)
Y	Reserved		
Z	Reserved		
CR	Terminates data transfer	MMC - PHC10-2 PHC10-2 - MMC	Carriage return: HEX 0D, OCTAL 015
XON	Enable MMC to send data	PHC10-2 - MMC	ASCII code DC1: HEX 11, OCTAL 021
XOFF	Inhibit MMC from sending data	PHC10-2 - MMC	ASCII code DC3: HEX 13, OCTAL 023

FLOWCHART 1 - OPERATION OF PHC10-2 SYSTEM WITH PH10 DISCONNECTED

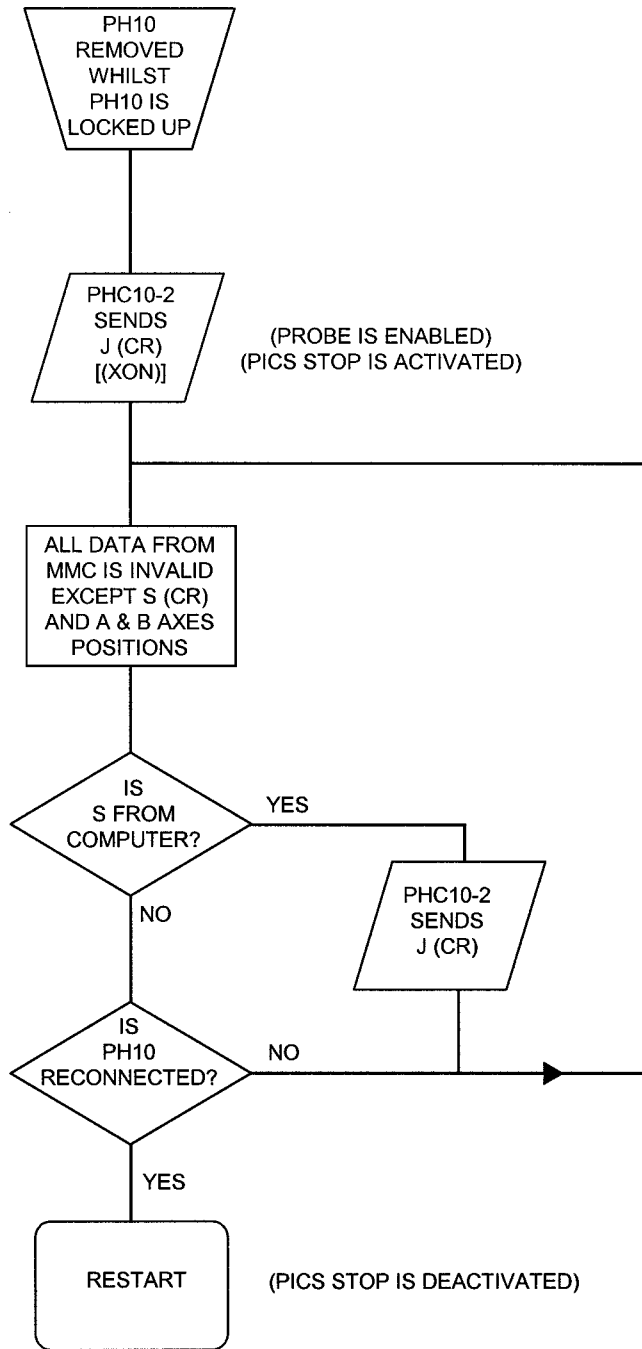



FLOWCHART 2 - EXCESS FORCE APPLIED TO PH10

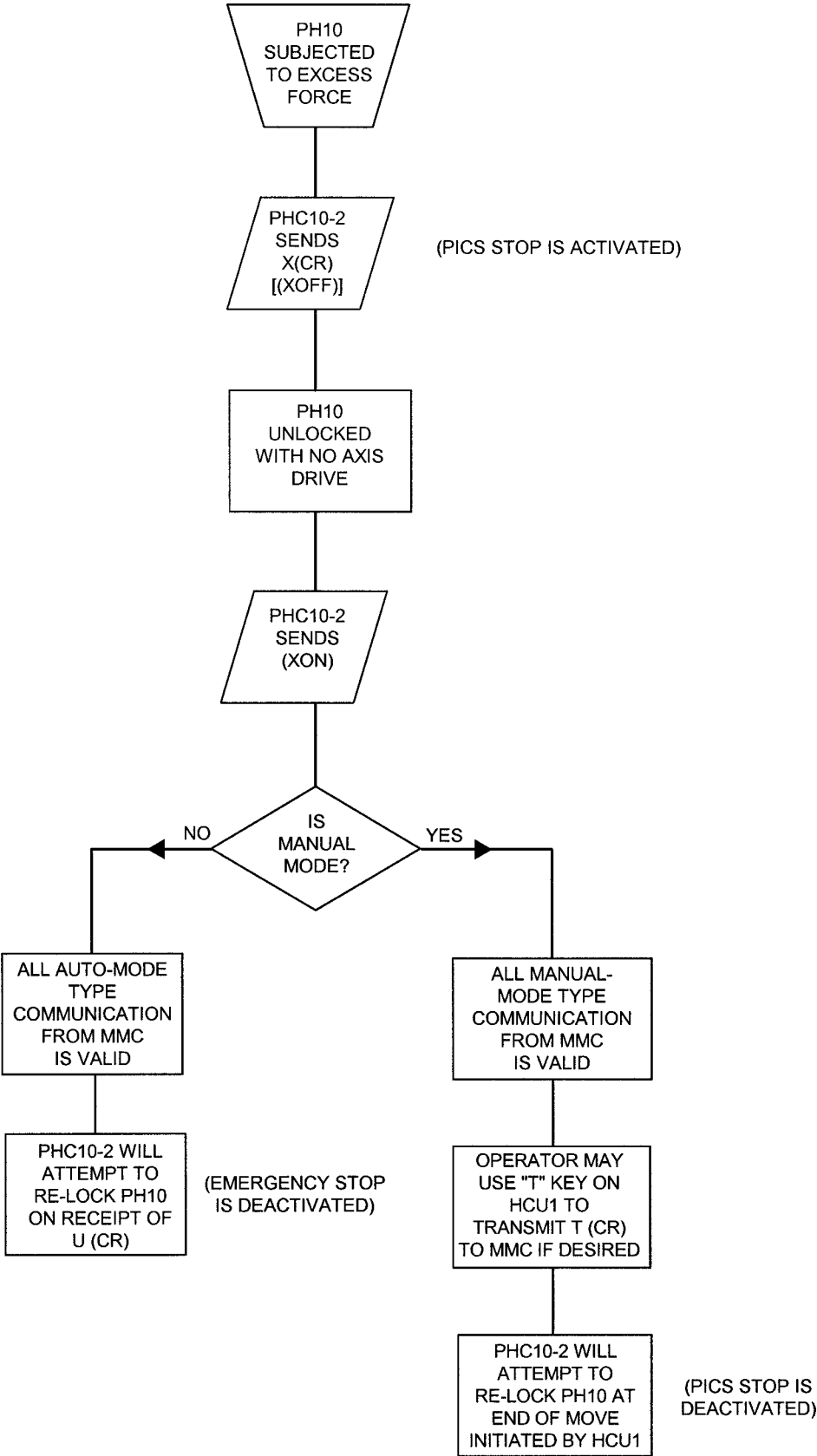

FLOWCHART 3 - OPERATION OF PHC10-2 IN STANDBY LOOP

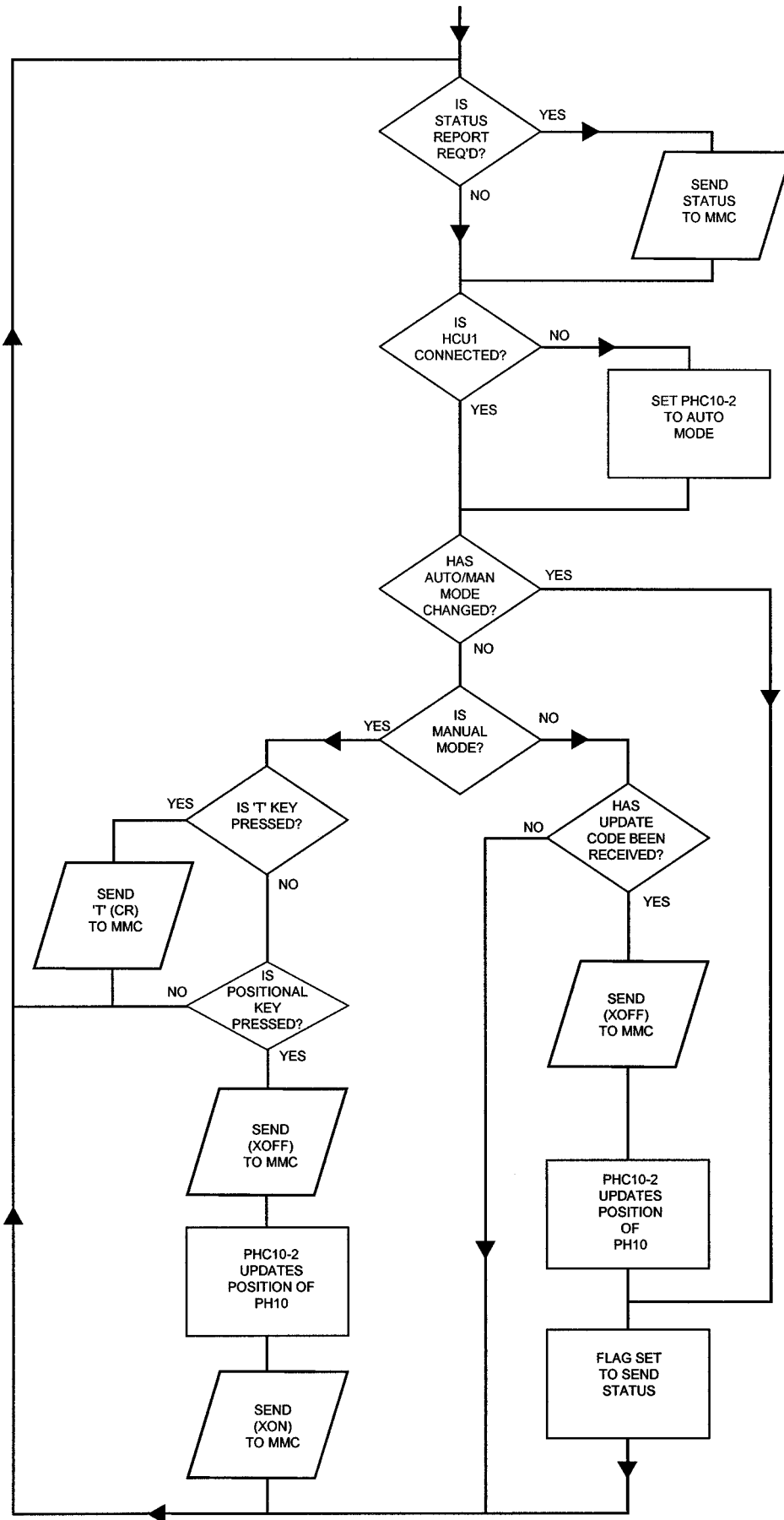

FLOWCHART 4 - RESPONSE OF PHC10-2 TO CHARACTERS TRANSMITTED BY MMC

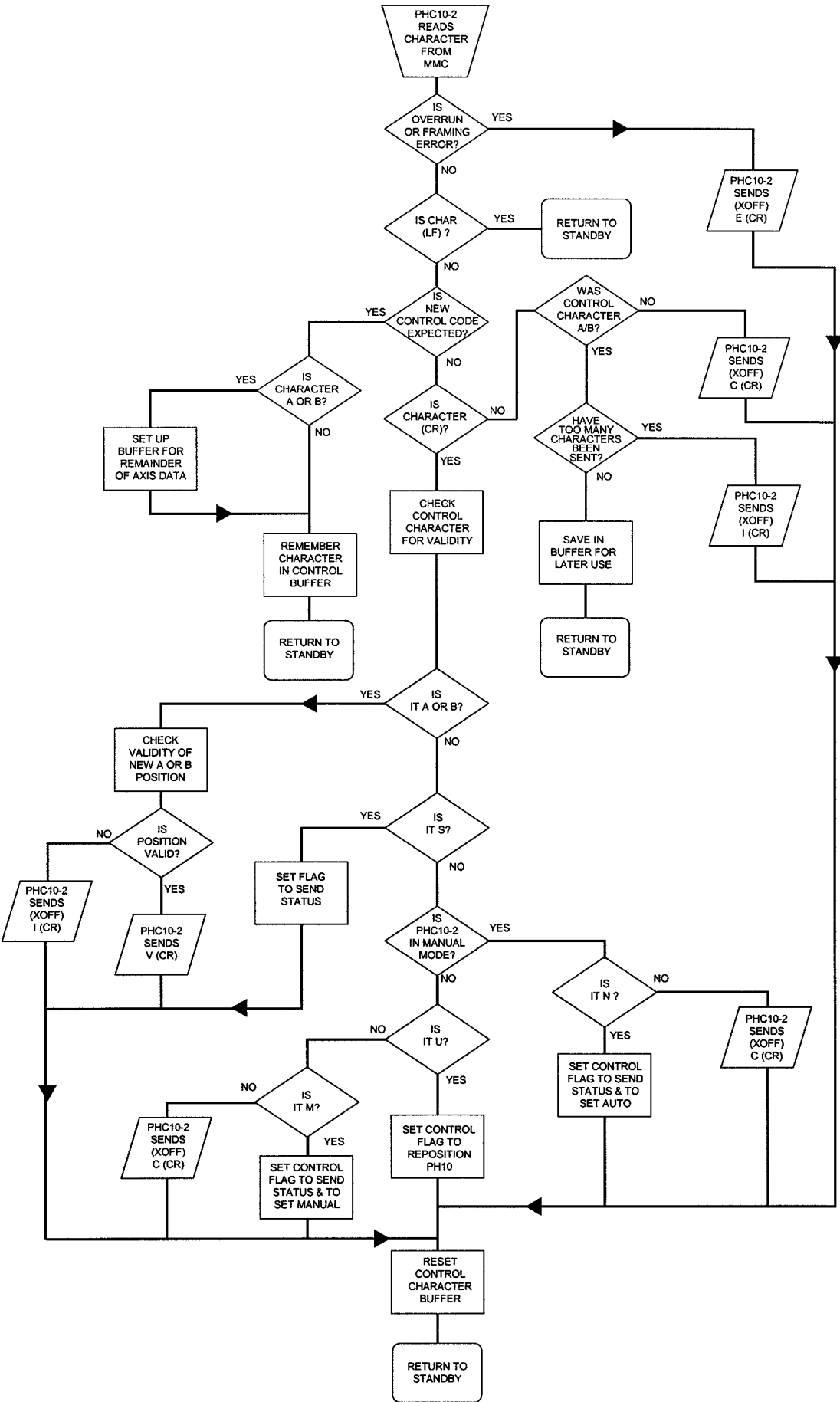









FLOWCHART 8 - OUTPUT SUBROUTINE TO SEND DATA TO PHC10-2

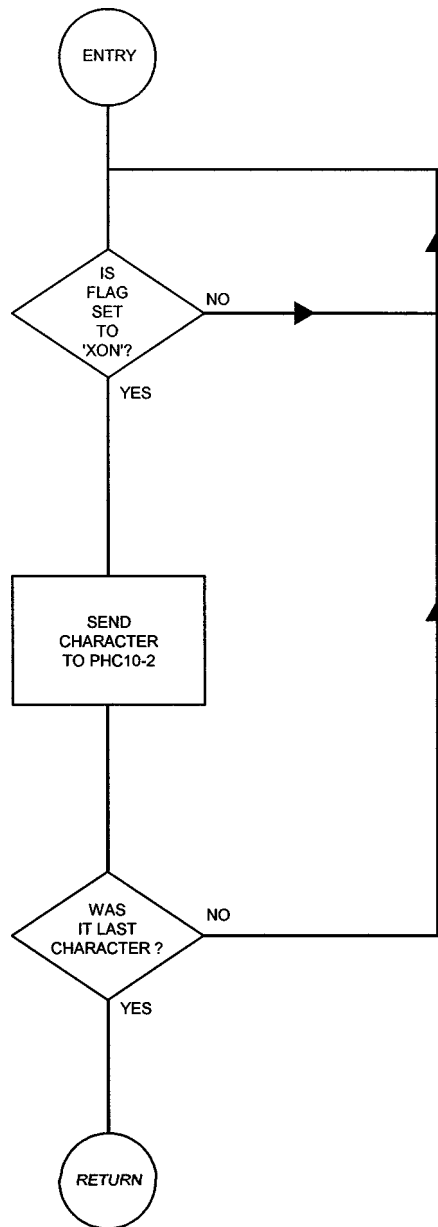



FLOWCHART 9 - SUBROUTINE TO SEND NEW AXIS POSITION TO PHC10-2

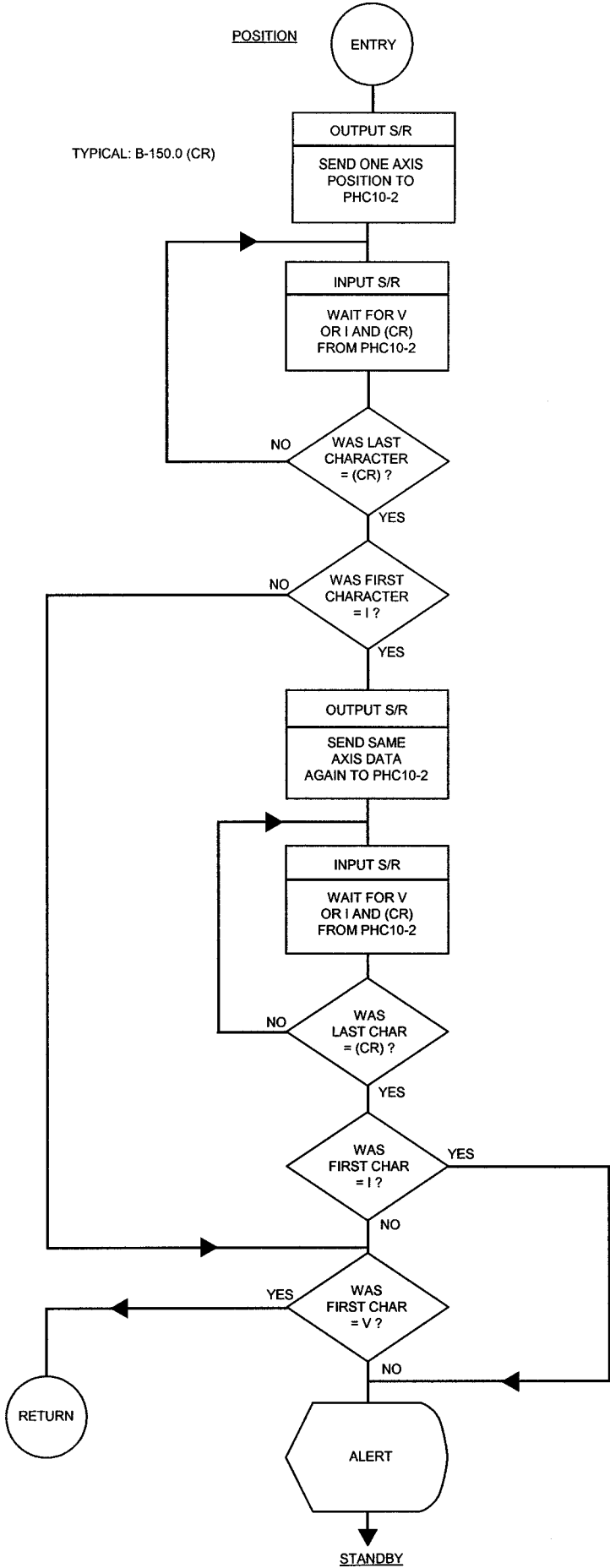

**FLOWCHART 10 - SUBROUTINE TO WAIT FOR AND CHECK STATUS TRANSMISSION FROM PHC10-2**

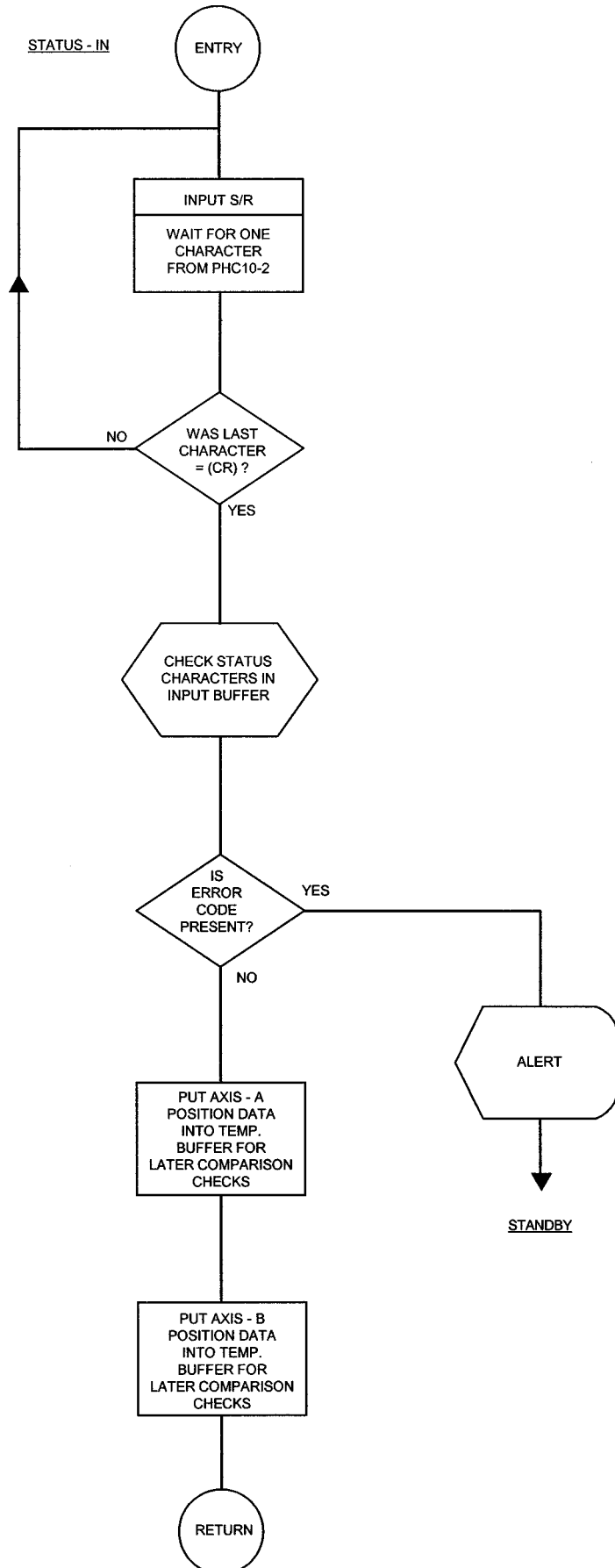

---

## IEEE488

### 7.0 Definition of terms

- 7.1 "PH10" is the probe head which orientates the probe itself in two axes.
- 7.2 "PHC10-2" is the electronic controller which controls the PH10 head and communicates with the measuring machine control computer.
- 7.3 "HCU1" is the optional hand-held control/display module used by the operator for controlling the PH10 when the PHC10-2 system is in manual mode. It also has a means of transmitting to the measuring machine controller computer.
- 7.4 "MMC" is the measuring machine computer used for controlling the PHC10-2 system and the measuring machine itself.
- 7.5 "STATUS" is the status word transmitted by the PHC10-2 to define the current state of the PHC10-2 system. It includes HCU1 status (code H); PH10 error codes if any (F, O and D); PHC10-2 status (M); PH10 position (A(POSITION)B(POSITION)(CR)(LF)). In the absence of a PH10 the status word will consist only of J (CR) (LF).
- 7.6 "(POSITION)" refers to the angular axis data transmitted between the PHC10-2 and the MMC. The positions are composed of ASCII numerals, + and - signs and "decimal point" ("period" or "full-stop"; ASCII code 2E hexadecimal, 056 octal).
- 7.7 "GPIB" refers to the IEEE General Purpose Instrument Bus.
- 7.8 GPIB terms are defined as follows:
- |       |         |  |
|-------|---------|--|
| 7.8.1 | TALK    | The MMC addresses the PHC10-2 as TALKER.                         |
| 7.8.2 | LISTEN  | The MMC addresses the PHC10-2 as a LISTENER.                     |
| 7.8.3 | REN     | This refers to the REMOTE ENABLE function of the GPIB.           |
| 7.8.4 | GET     | This refers to the GROUP EXECUTIVE TRIGGER function of the GPIB. |
| 7.8.5 | DCL/SDC | These refer to the DEVICE CLEAR function of the GPIB.            |
| 7.8.6 | SRQ     | This refers to the SERVICE REQUEST function of the GPIB.         |
| 7.8.7 | SPOLL   | This refers to the SERIAL POLL function of GPIB.                 |
| 7.8.8 | PPOLL   | This refers to the PARALLEL POLL function of the GPIB.           |
| 7.8.9 | IFC     | This is the INTERFACE CLEAR function of the GPIB.                |
- 7.9 "START" is the electrical power-up of the PHC10-2 system. An SRQ will be called by the PHC10-2 at the end of the power-up routine, with either code R or code J.
- 7.10 "RESTART" refers to the PH10 being refitted to the system whilst the PHC10-2 is powered-up. The GPIB is not, however, re-initialised, and the address and parallel poll bit are unchanged. An SRQ will be called as in section 7.9. All data, including auto and manual positions, is lost. The PH10 is not moved in position, although if unlocked it will be locked.

- 7.11 "MOVE COMPLETE" state is a condition in which the PHC10-2 is in stand-by mode, not updating the PH10 position. The MOVE COMPLETE state is ended by the start of repositioning the PH10, either in auto or manual mode, or during unlocking the PH10 in an emergency. The PH10 probe is enabled during the MOVE COMPLETED state, but not while the PH10 position is being updated.
- 7.12 "PICS" refers to the Product inter-connection system incorporated into the PHC10-2 and other Renishaw interfaces and controllers. The PICS signals are detailed in the PH10 Series Installation Guide (Part Number H-1000-5071) and only the "STOP" (system problem) is referred to in this document.

---

## 8.0 Parallel data transmission

- 8.1 Data is transmitted between the PHC10-2 and the MMC by means of an IEEE488 GPIB link using standard ASCII code. Data from the PHC10-2 to the MMC has bit 8 set to zero; for data to the PHC10-2 from the MMC, bit 8 is "don't care".
- 8.2 Control of the PHC10-2 is by means of the GPIB control bus.
- 8.3 The PHC10-2 transmits error and status by means of serial and parallel polls.
- 8.4 The letter codes used are all upper case (capitals). The codes are detailed in section 9, but are summarised in Table 2 for convenience.
- 8.5 The address of the PHC10-2 can be set up to any code from 0 to 31 by means of ADDRESS switches on the PHC10-2 (see PH10 Series Installation Guide, Part Number H-1000-5071). Address 31 is not, however, permitted by GPIB.
- 8.6 The parallel poll register bit can be selected by means of the PPOLL switches on the PHC10-2 (see PH10 Series Installation Guide, Part Number H-1000-5071). The bit selected is the binary code of PPOLL switches 3, 2, 1 plus one (e.g. switch code 010 is bit 3, decimal 4).
- 8.7 The PHC10-2 defines its address and parallel poll bit (sections 8.5, 8.6) on START, RESTART or receipt of SDC or DCL.
- 8.8 During a MOVE state the PHC10-2 will not respond to any communication from the MMC. Any communication initiated during this time is held in abeyance until the MOVE COMPLETE state is entered. It is recommended that no communication be attempted during a move as it may cause a delay in servicing SRQs, with the possible result that of two consecutive SRQs only the last one may be received by the MMC. This applies particularly to high level language machines.
- 8.9 It may be necessary for faster computers to wait for the PPOLL bit to indicate MOVE before waiting for MOVE COMPLETED after using the GET command.
- 8.10 The PHC10-2 should be Untalked and Unlistened (UNT, UNL) after relevant addressed commands to it. It should not be left in a TALK or LISTEN state.

## 9.0 Transmission from MMC to PHC10-2

- 9.1 Transmission may take place from the MMC to the PHC10-2 only when the PHC10-2 is in the MOVE COMPLETED state, as defined by the parallel poll bit (see section 9.3.2).
- 9.2 Control to the PHC10-2 is by means of the GPIB control bus. Where the response from the PHC10-2 is expected to consist of STATUS, the MMC must wait for the terminating (LF) before sending any other data to the PHC10-2. Failure to wait for end of STATUS may result in confusion, as further communication may interrupt STATUS transmission and abort it.
- 9.2.1 REN This control line sets an addressed PHC10-2 to AUTO (REMOTE) or MANUAL (LOCAL) mode.
- 9.2.2 IFC This command resets the PHC10-2 GPIB interface.
- 9.2.3 DCL/SDC These commands reset the PHC10-2 GPIB and redefine the device address and parallel poll bit.
- 9.2.4 GET This command will cause the PHC10-2 to update the PH10 position. This command is only valid in auto mode, when the position of PH10 will set up from the last A and B positions sent by the MMC. The last known manual position is ignored and lost by the use of GET. No further commands or data may be sent by the MMC until the MOVE COMPLETE state is resumed, as indicated by PPOLL.
- 9.3 The MMC may use parallel and serial polling methods to acquire data from the PHC10-2.
- 9.3.1 SPOLL The MMC may conduct a serial poll at any time that the PHC10-2 is in a MOVE COMPLETE state, but MUST conduct a serial poll if the PHC10-2 calls a SRQ (see section 10.2).
- 9.3.2 PPOLL The MMC may conduct a parallel poll at any time. The parallel poll bit is set if the PHC10-2 is in a MOVE COMPLETE state, otherwise it is reset (see section 8.6).
- 9.4 Positional data may be sent to the PHC10-2 during any MOVE COMPLETE state, although it is pointless when the PH10 is disconnected. Data is transmitted to the PHC10-2 via the GPIB data bus by addressing the PHC10-2 as a LISTENER. At each end of transmission the MMC should send UNL (Unlisten) to the PHC10-2. Each character transfer handshake is held off until acceptance of that character by the PHC10-2. Validation of the angle is carried out before release of the handshake of the first (CR) or (LF).
- 9.4.1 All data transmissions from the MMC to the PHC10-2 must be terminated by (TERM). This comprises a Carriage Return Character (CR) and/or a Line Feed Character (LF). AO (CR) (LF), AO (LF) (CR), AO (CR) and AO (LF) are all valid.
- 9.4.2 Unrecognised characters received by the PHC10-2 will be ignored, but are undesirable. Some computers running high level languages (e.g. HP85 BASIC) transmit a high number of spaces or nulls after a data string. Where possible this should be suppressed to allow the PHC10-2 to spend more time on internal status checks, and to increase the speed of response of the system to SRQs.
- 9.4.3 All angles must be precise multiples of 7.5°. If the decimal place digit is zero (.0) it may be excluded or included. A decimal point without a following 0 or 5 is invalid.

9.4.4 Valid angles are as follows:

A axis: +0.0 to +105.0° in 7.5° increments.  
B axis: -180.0 to +180.0° in 7.5° increments.

9.4.5 Angle 0.0 is always positive; only B axis may contain negative data. In the absence of a sign character the PHC10-2 assumes that positive data is intended. Data format is (AXIS) (SIGN) (ANGLE) (TERM) where (SIGN) is optional if positive.

9.4.6 (POSITION) from the MMC to the PHC10-2 may have leading zeros and decimal placed zero suppressed or non-suppressed; 0, 0.0, 00.0 and 000.0 are all equally valid.

9.4.7 After the initial transmission of A and B axes to the PHC10-2, A (TERM) and B (TERM) are valid transmissions, but as the PHC10-2 remembers its last A and B coordinates these transmissions serve no real purpose.

9.4.8 If one axis position is to be repeated during the next PH10 move, that axis does not have to be sent to the PHC10-2 again, although it may be advisable to do so. For example, if the last auto mode position was A0.0, B7.5 and the next is A15.0, B7.5 then only A15.0 (TERM) need be transmitted.

9.4.9 If the PHC10-2 receives an invalid angle from the MMC then the PHC10-2 will call an SRQ with code I (see section 10.2.2). The SRQ will be initiated at the same time as the final data handshake is completed.

9.4.10 Examples of valid angular data are A+0.0 (TERM), B0 (TERM), B-15 (TERM), A90.0 (TERM), B+007.5 (TERM).

9.4.11 Examples of invalid angular data are A-7.5 (TERM), B-0.0 (TERM), A+150 (TERM), B-187.5 (TERM), A7.2 (TERM), A0.0 B15.0 (TERM).

9.4.12 The PHC10-2 sets no limit on the number of times each axis position is transmitted to it.

## 10.0 Transmission from PHC10-2 to MMC

- 10.1 Transmission from the PHC10-2 is of three main types; STATUS, SRQ and response to SPOLL.
- 10.2 SRQ (Service Request) is generated by the PHC10-2 in response to an internal status condition which it considers the MMC should know about and respond to. The codes generated are ASCII alphabetic, i.e. data bit 7 set. Data bit 8 is not used, and remains at zero.

The codes are as follows:

- 10.2.1 **C** The command received from the MMC was invalid in the current PHC10-2 mode, and was ignored.
- 10.2.2 **I** The angular data was invalid, either numerically or in syntax. Any ambiguity may be cleared by sending (TERM) (which may or may not result in generation of a second I code), followed by correct positional data.
- 10.2.3 **J** The PH10 has just been removed from the PHC10-2 system. This code may or may not be preceded by a SRQ containing the code X (see section 10.2.7). Presence of the PH10 is checked periodically during the MOVE COMPLETE state, whether or not the PH10 is fitted. Refitting the PH10 will result in the PHC10-2 system restarting as if from power-up, except that address and parallel poll bit are not renewed. The MMC should check for J continually on an interrupt basis as its cause may be due to cable or probe damage whilst the machine or probe is in motion. Action taken should be to shut down any machine motion. The PICS STOP signal is activated by the PHC10-2 and is held active until the PH10 is reconnected.
- 10.2.4 **O** This indicates that the PH10 has an obstruction error. It implies that the PH10 failed to complete a move in a predetermined time, and is checked at appropriate points during PH10 move sequences. The error condition is caused by the PH10 encountering an external obstruction during a move, or by an obstruction within the PH10 itself. The PH10 position is not guaranteed in this error state. To prevent potential damage to the PH10 it is recommended that the measuring machine is not moved while the PH10 position is being updated. The probe fitted to the PH10 is not enabled during a PH10 move. Initiating a move in AUTO (with or without a new POSITION) or in MANUAL should re-lock the PH10 after the obstruction has been removed (see also section 10.4.4). The PICS STOP signal is activated by the PHC10-2 and is held active until the PHC10-2 receives a command to recover the position of the PH10.
- 10.2.5 **R** The PH10 has just been refitted to the system, and the PHC10-2 is ready for commands.
- 10.2.6 **T** This is generated when the "T" button on the HCU1 is operated. This feature is only active during a MOVE COMPLETE state in MANUAL mode. Its only significance is that attributed to it by the MMC program.



10.2.7 **X** Generated when, in MOVE COMPETE condition with no datum error, a loss of datum occurs. As a direct result of datum loss, the PH10 will be unlocked by the PHC10-2. The error is continually checked for under the stated conditions, and is usually caused by the PH10 colliding with a workpiece. The MMC should check this code on interrupt, and shut down machine movement immediately. It is recommended not to move the measuring machine components whilst the PH10 is unlocked and/or moving, as this condition cannot be monitored with the PH10 in this state. The probe is enabled after the emergency unlock occurs. Initiating a move in either AUTO or MANUAL will lock up the PH10. New coordinates may be sent if required (see also section 10.4.5). The PICS STOP signal is activated by the PHC10-2 and is held active until the start of the recovery move.

10.3 **SPOLL** If no SRQ is pending, the serial poll will contain the following data if the relevant bit is set:

BIT 1	OVERLOAD/EXCESS FORCE ERROR
BIT 2	MOVE COMPLETE
BIT 3	OBSTRUCT ERROR
BIT 4	DATUM ERROR
BIT 5	RESERVED
BIT 6	RESERVED
BIT 7	NOT SET
BIT 8	RESERVED

If the PHC10-2 is moving the PH10, then all bits are NOT SET (unless SRQ is pending).

10.4 STATUS from the PHC10-2 to the MMC can be of two types: full status, used under normal error and non-error conditions; and abbreviated status, used for emergency action errors. Full status is transmitted in response to a status request from the MMC; i.e. when the PHC10-2 is addressed as a talker. It is transmitted in the form:

HOFDMA (POSITION) B (POSITION) (CR) (LF)

where any or all of HOFDM may be absent. The sequential order of HOFDM may not always be consistent. (LF) is accompanied by assertion of EOI (End or Identify). The error status of the PHC10-2 system is reset at the start of either an auto or manual PH10 move, but is never carried over to the next move.

10.4.1 **H** is the code prefixed to the PH10 positional data to indicate that the HCU1 is not connected. Absence of H in the status word implies that the HCU1 is connected. Manual mode cannot be selected if H is present. The system reverts to auto mode if the HCU1 is removed with the system in manual mode. H and M are mutually exclusive.

10.4.2 **M** is used to indicate that the PHC10-2 system is in manual mode. Absence of M implies that the system is in auto mode. The system powers up in manual mode if the HCU1 is connected, otherwise auto mode is selected. Manual mode cannot be selected in the absence of HCU1, so that M and H are mutually exclusive. Auto/manual condition of the PHC10-2 is monitored during MOVE COMPLETE states except when the PH10 is disconnected.

10.4.3 **D** indicates that the PH10 has a datum error due to not being seated correctly. Accuracy of PH10 positioning is not guaranteed when this error code is present. Absence of the code implies no datum error. A datum error arising during a MOVE COMPLETE state is translated as an emergency overload error and results in an SRQ call with code X (see section 10.2.7).

10.4.4 **O** This indicates that the PH10 has an obstruction error (see section 10.2.4). Absence of the code implies no obstruction error. Code D always accompanies code O.

10.4.5 **F** indicates that the PH10 was unlocked in a MOVE COMPLETE state, due to excessive force applied to the PH10 (resulting in an overload error). F is the code used in STATUS to indicate that an SRQ code X has been transmitted to the MMC (see section 10.2.7). Absence of code F implies no overload error. Code D always accompanies Code F.

10.4.6 The main part of STATUS comprises the A and B axis positions. They are transmitted in the form

A(POSITION)B(POSITION)(CR)(LF)

and this expression is the minimum full status word which will be transmitted. It implies auto mode with the HCU1 connected and no PH10 errors. (POSITION) is as defined in section 9.4.

10.5 **J** is an abbreviated status code sent to the MMC to show that the PH10 is not connected to the system. The full format is J(CR) (LF). It will be transmitted in response to a status request from the MMC (PHC10-2 addressed as a talker). (LF) will be accompanied by EOI (End or Identify). Full status will not be sent if the PH10 is not fitted. If full status is being transmitted when the PH10 is removed it will be aborted, resulting in, for example, A90.0B3J (CR) (LF) (see section 10.2.3).

## 11.0 Flowchart descriptions

- 11.1 Flowcharts 11 to 14 describe the action of the PHC10-2 in response to various stimuli as far as communication to and from the MMC is concerned.
- 11.1.1 Flowchart 11 shows the PHC10-2 response with no PH10 connected. A status request from the MMC is valid, resulting in a response from the PHC10-2 of J (CR) (LF). GET is invalid, and will return SRQ C to the MMC; communication is valid but does not serve any real purpose.
- 11.1.2 Flowchart 12 shows that the PHC10-2 reacts the same way to the emergency condition of the PH10 colliding with something which forces it to unlock. The emergency should be acted on by the MMC immediately the X code is received by it. The MMC may switch the PHC10-2 to either auto or manual as desired. All communication is valid depending on MODE of the PHC10-2 only.
- 11.1.3 Flowchart 13 describes the system status checks performed when the PHC10-2 is idling in the MOVE COMPLETE state. The probe fitted to the PH10 is enabled during this period, and disabled during any move of the PH10. The PPOLL bit is set in the MOVE COMPLETE state, and SPOLL contains either a code letter or system status. Any communication from the MMC should take place during this state. PPOLL and SPOLL are cleared during a move. Auto/manual mode can be changed either by the HCU1 being removed (but not when it is replaced) or by the MMC command. Response to the "T" key is entirely in the hands of the MMC program; for an example see Flowchart 16.
- 11.1.4 Flowchart 14 shows the response of the PHC10-2 system to positional data transmitted by the MMC. Axis data is held in buffers until (CR) or (LF) is received. The data is then validated. SRQ I is returned to the MMC if too many (otherwise valid) characters are received, or if the data is not a valid angle. Data is received by the PHC10-2 using an interrupt technique, during MOVE COMPLETE state only. The more excess characters transferred to the PHC10-2 by the MMC, the more danger of delays in error conditions being reported to the MMC. Some computers running high-level languages send a string of NULLS or SPACES (BLANKS) after a data string. Where possible this should be suppressed. It is also preferable for either (CR) or (LF) to be sent, but not both.
- 11.2 Flowcharts 15 to 18 are provided to give help in producing a simple computer program, suitable for operating the PHC10-2 system. It is anticipated that this program will be used only as a guide, useful in familiarising the programmer with the PHC10-2 system before customising the system to his own requirements. The flowcharts refer to a "data file". This is a hypothetical file containing positional data for moving the measuring machine and the PH10 combination during automatic measuring cycles. The main program is shown on flowcharts 15 to 17, whilst 18 outlines an interrupt handling routine. MMC refers to the measuring machine computer, and MACHINE refers to the measuring machine. Various system conditions are assumed to be of interest to the machine operator, and these are suggested on the flowcharts as ALERT and NOTIFY, distinguishing between error and non-error conditions. Relevant data is displayed on the MMC console.
- 11.2.1 Flowchart 15 shows the START/RESTART program. It is advisable to have the MMC switched on and running before powering up the PHC10-2 system or refitting the PH10. Immediately after START/RESTART begins, the PHC10-2 sets up the PPOLL bit and initiates an SRQ with code R. PHC10-2 should not be addressed as a talker or listener nor should serial poll be conducted unless PPOLL bit is set to indicate MOVE COMPLETE.

- 11.2.2 Flowchart 16 gives an example of the use of the manual mode of PHC10-2 system operation. It is assumed that the MMC has to somehow learn where to drive the PH10/measuring machine combination in order to perform certain measurements in an automatic sequence. This flowchart shows a method of implementing this "teaching" mode, the principle being that the operator moves the probe into a suitable position using the HCU1 and machine control, and then uses the "T" key on the HCU1 to induce the MMC to remember the coordinates of the machine and probe. Because the time available for acquisition of the PHC10-2 status and for the MMC to perform calculations on it is approximately 900ms after SRQ T is initiated by PHC10-2, it may be desirable to put the PHC10-2 system into auto mode for a while to prevent the operator from performing further moves. The HCU1 has an indicator to show the operator whether auto or manual mode is selected. The PHC10-2 does not check for HCU1 keys whilst it is sending STATUS.
  - 11.2.3 Flowchart 17 (AUTO mode) shows the system being used in an automatic measuring sequence, using the hypothetical "data file" to provide various movement coordinates. Because the method of performing the measurement will vary between types of machines, no program outline is given for this function.
  - 11.2.4 Flowchart 18 gives a subroutine for dealing with service requests from the PHC10-2. This input routine should be run under interrupt in order to deal with unsolicited data from the PHC10-2, such as X and J for example. X and J should be dealt with immediately to save possible damage to the PH10 and/or the measuring machine.
- 11.3 The PHC10-2 may, under certain error conditions, not respond to MMC commands. This happens particularly if a bus hang-up occurs, usually through addressing the PHC10-2 at the wrong time. This can be overcome by use of the DCL/SDC/IFC commands.

<b>TABLE 2 - IEEE488 COMMUNICATION CODES</b>			
<b>CODE</b>	<b>FUNCTION</b>	<b>FROM - TO</b>	<b>SRQ OR FORMAT</b>
DCL	Reset PHC10-2	MMC - PHC10-2	
SDC	Reset PHC10-2	MMC - PHC10-2	
IFC	Reset PHC10-2 interface	MMC - PHC10-2	
GET	Update PH10 position	MMC - PHC10-2	
TAG	Request status from PHC10-2	MMC - PHC10-2	
UNT	End data transfer	MMC - PHC10-2	
LAG	Send position to PHC10-2	MMC - PHC10-2	
UNL	End data transfer	MMC - PHC10-2	
REN	Auto mode	MMC - PHC10-2	
GTL	Manual mode	MMC - PHC10-2	
SPOLL	Read PH10 status or error	MMC - PHC10-2	
PPOLL	Check PHC10-2 MOVE COMPLETE status	MMC - PHC10-2	
A	Prefix for AXIS-A data	MMC - PHC10-2 PHC10-2 - MMC	A(POSITION)(TERM) or A(TERM) A(POSITION)B(POSITION)(CR)(LF)
B	Prefix for AXIS-B data	MMC - PHC10-2	B(POSITION)(TERM) or B(TERM)
C	Invalid control character	PHC10-2 - MMC	SRQ
D	PH10 datum error	PHC10-2 - MMC	DA(POSITION)B(POSITION)(CR)(LF)
E	Reserved		
F	Overload error	PHC10-2 - MMC	FDA(POSITION)B(POSITION)(CR)(LF)
G	Reserved		
H	HCU1 disconnected	PHC10-2 - MMC	HA(POSITION)B(POSITION)(CR)(LF)
I	Invalid A or B AXIS data	PHC10-2 - MMC	SRQ

*continued on next page ...*

<b>TABLE 2 - IEEE488 COMMUNICATION CODES <i>continued</i></b>			
<b>CODE</b>	<b>FUNCTION</b>	<b>FROM - TO</b>	<b>SRQ OR FORMAT</b>
J	PH10 is disconnected	PHC10-2 - MMC	SRQ and J(CR)(LF)
K	Reserved		
L	Reserved		
M	PHC10-2 Manual mode	PHC10-2 - MMC	MA(POSITION)B(POSTION)(CR)(LF)
N	Reserved		
O	PH10 Obstruct error	PHC10-2 - MMC	SRQ or ODA(POSITION)B(POSITION)(CR)(LF)
P	Reserved		
Q	Reserved		
R	PH10 reconnected	PHC10-2 - MMC	SRQ
S	Reserved		
T	HCU1 'T' key	PHC10-2 - MMC	SRQ
U	Reserved		
V	Reserved		
W	Reserved		
X	Excess force/Overload error	PHC10-2 - MMC	SRQ
Y	Reserved		
Z	Reserved		
CR	Terminates data transfer	PHC10-2 - MMC MMC - PHC10-2	Carriage return : HEX OD OCTAL 015
LF	Terminates data transfer	PHC10-2 - MMC MMC - PHC10-2	Line feed : HEX OA OCTAL 012
TERM	Terminates data transfer	MMC - PHC10-2	Comprises CR and LF
LF from PHC10-2 is accompanied by assertion of END/OR IDENTIFY Line (EOI)			

FLOWCHART 11 - OPERATION OF PHC10-2 SYSTEM WITH PH10 DISCONNECTED

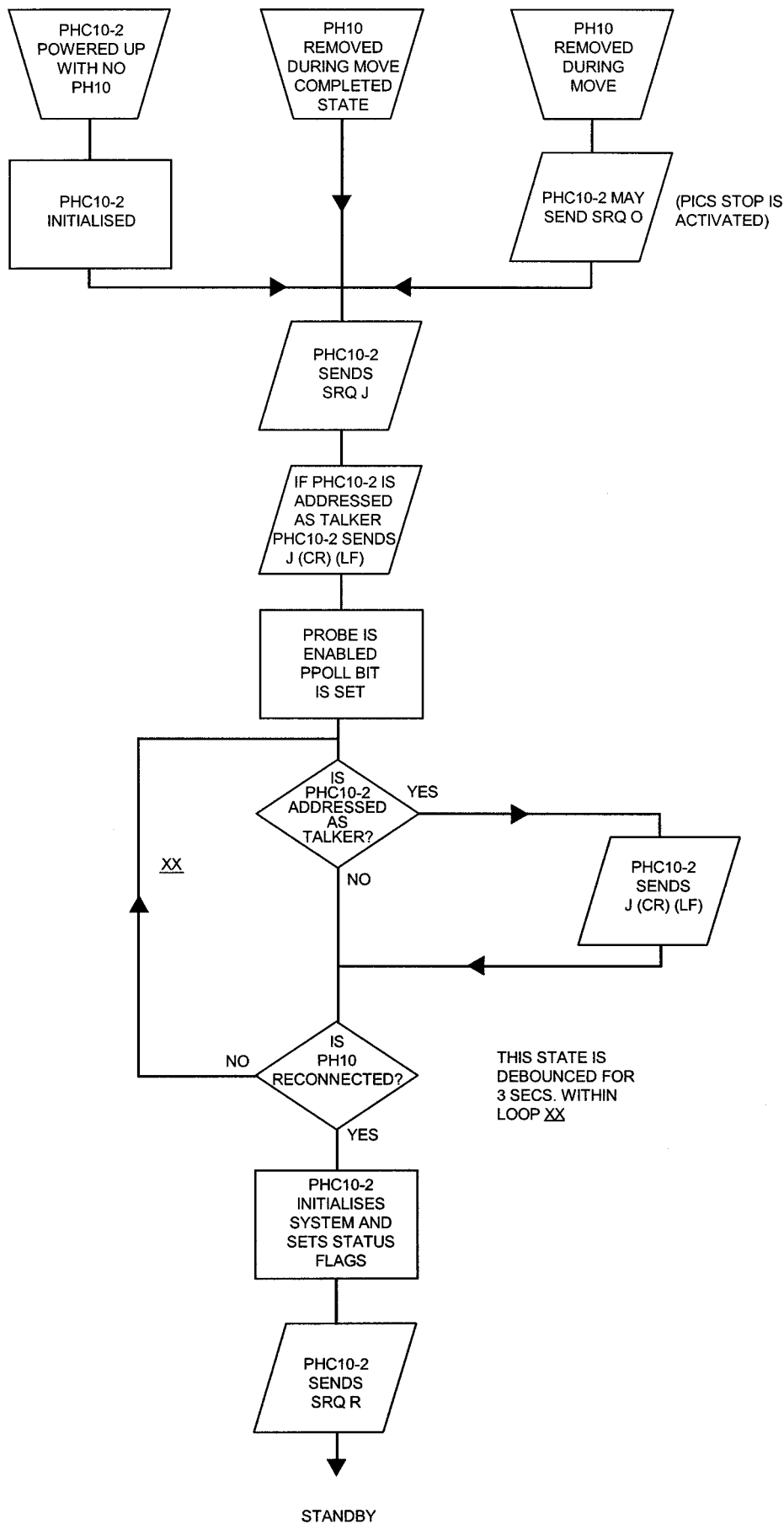

FLOWCHART 12 - EXCESS FORCE APPLIED TO PH10

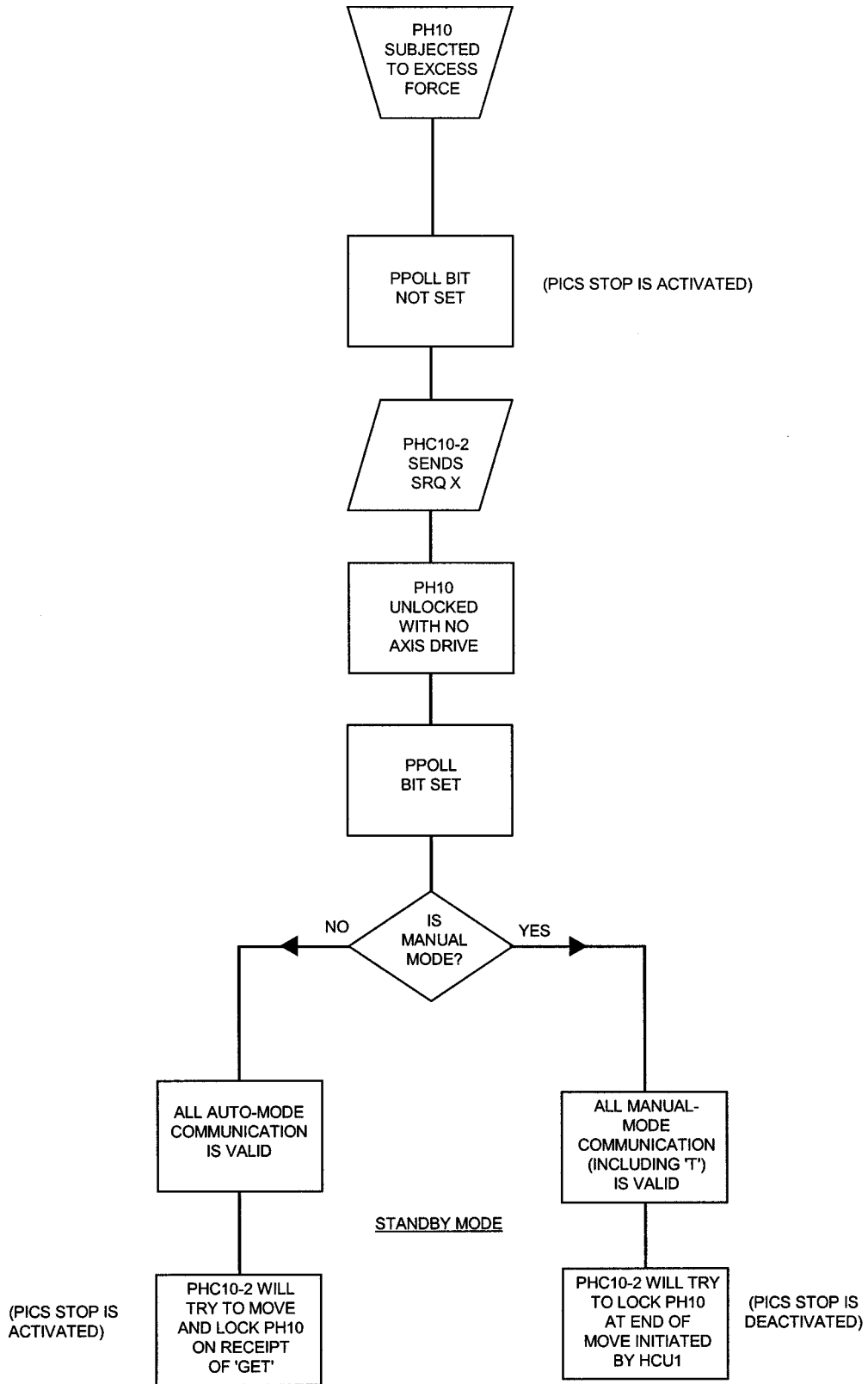



FLOWCHART 13 - OPERATION OF PHC10-2 IN STANDBY LOOP

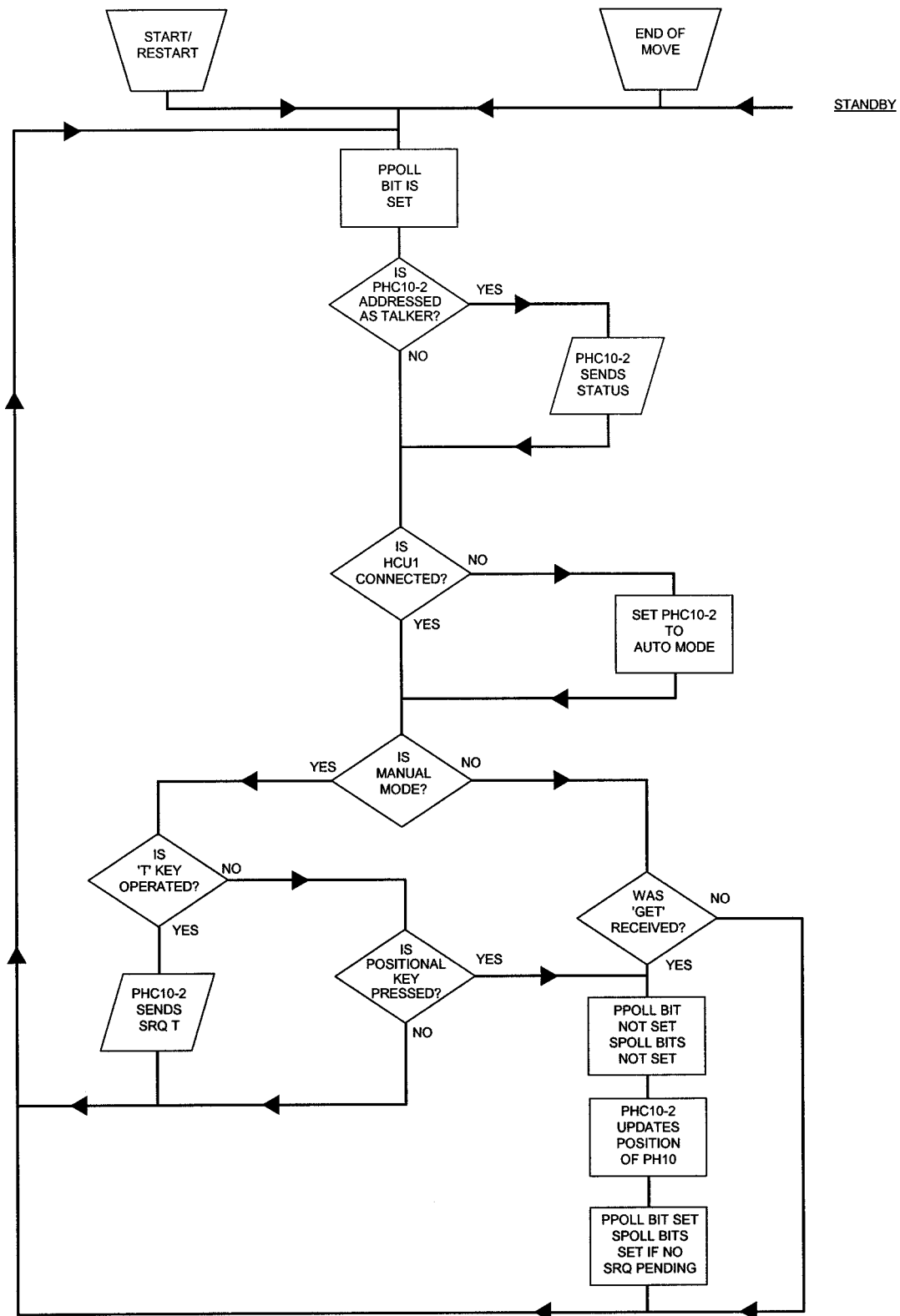

FLOWCHART 14 - DATA ACQUISITION BY PHC10-2

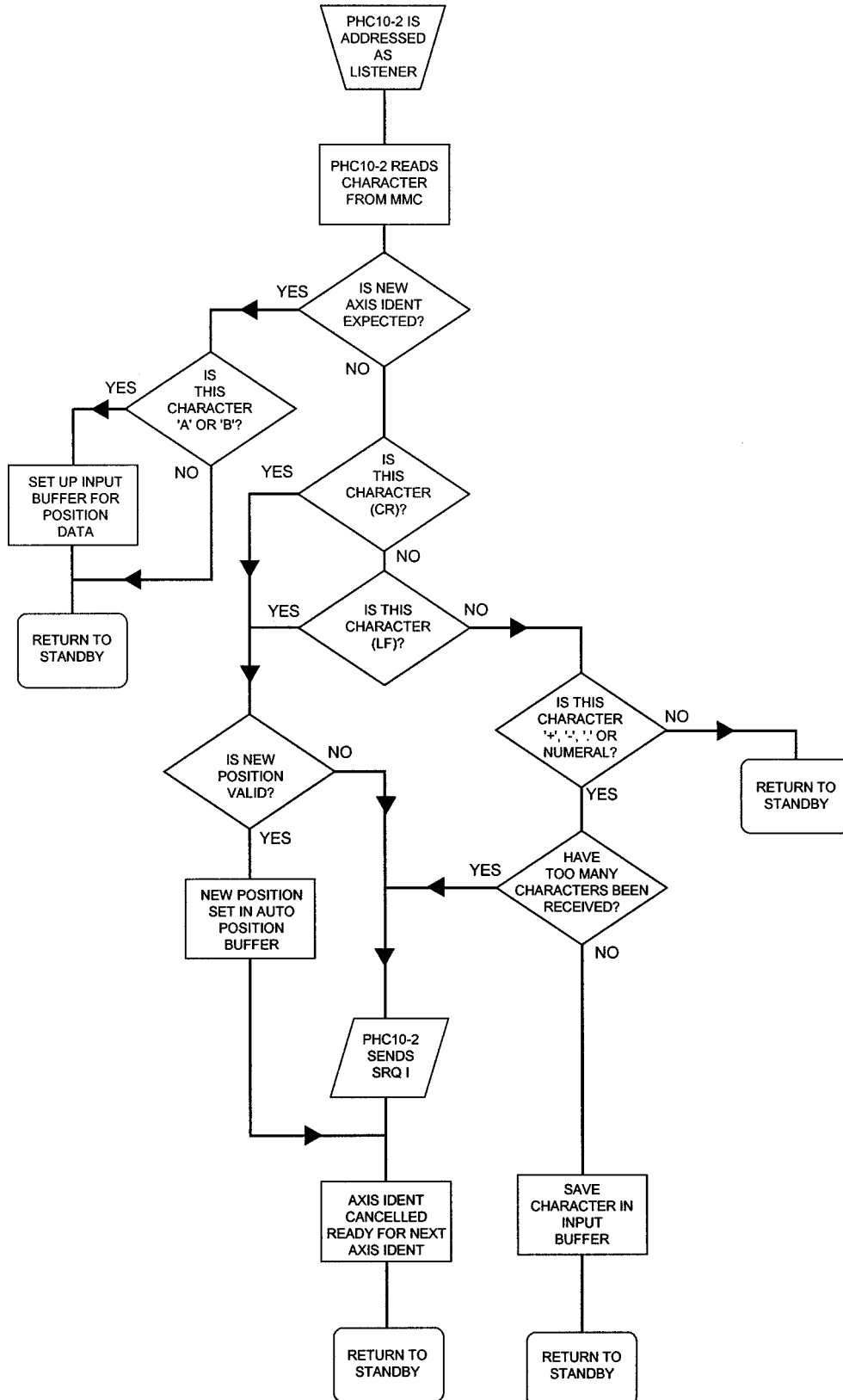

**FLOWCHART 15 - SUGGESTED OPERATION OF PHC10-2: START/RESTART**

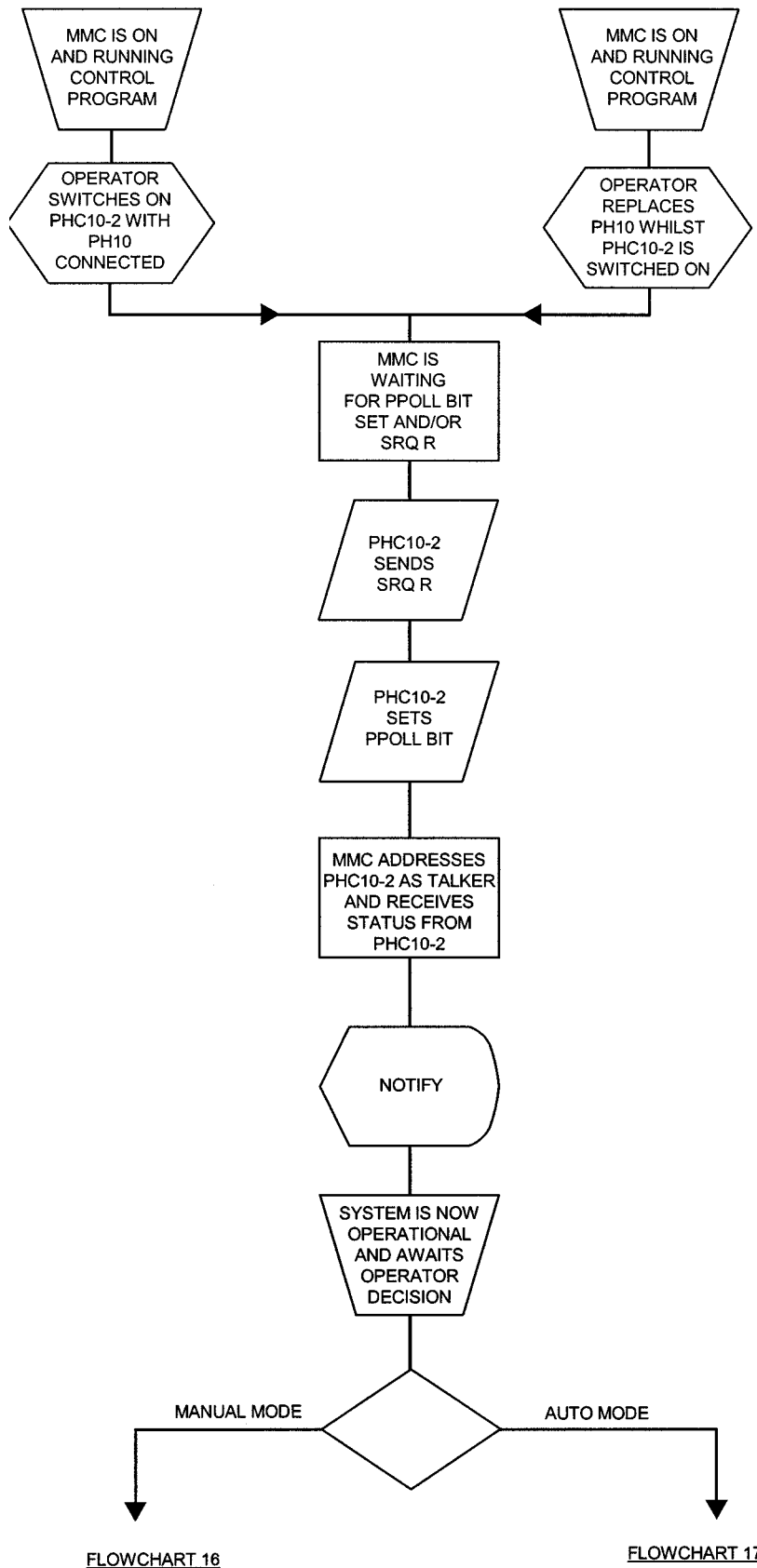

FLOWCHART 16 - SUGGESTED OPERATION OF PHC10-2 : MANUAL MODE

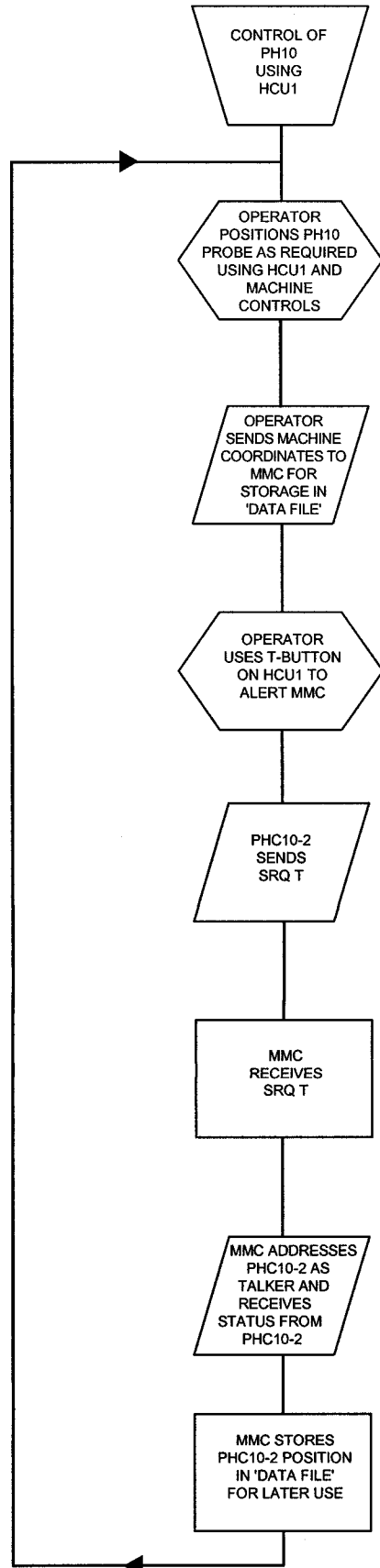

NOTE:  
 MINIMUM TIME AVAILABLE FOR STATUS ACQUISITION AFTER RECEIPT OF T IS APPROX 900ms.  
 IF MMC NEEDS TIME FOR COMPUTATION THEN MMC MAY PLACE PH10 IN AUTO MODE FOR THE DURATION. THIS WILL INHIBIT HCU1 OPERATION

FLOWCHART 17 - SUGGESTED OPERATION OF PHC10-2 : AUTO MODE

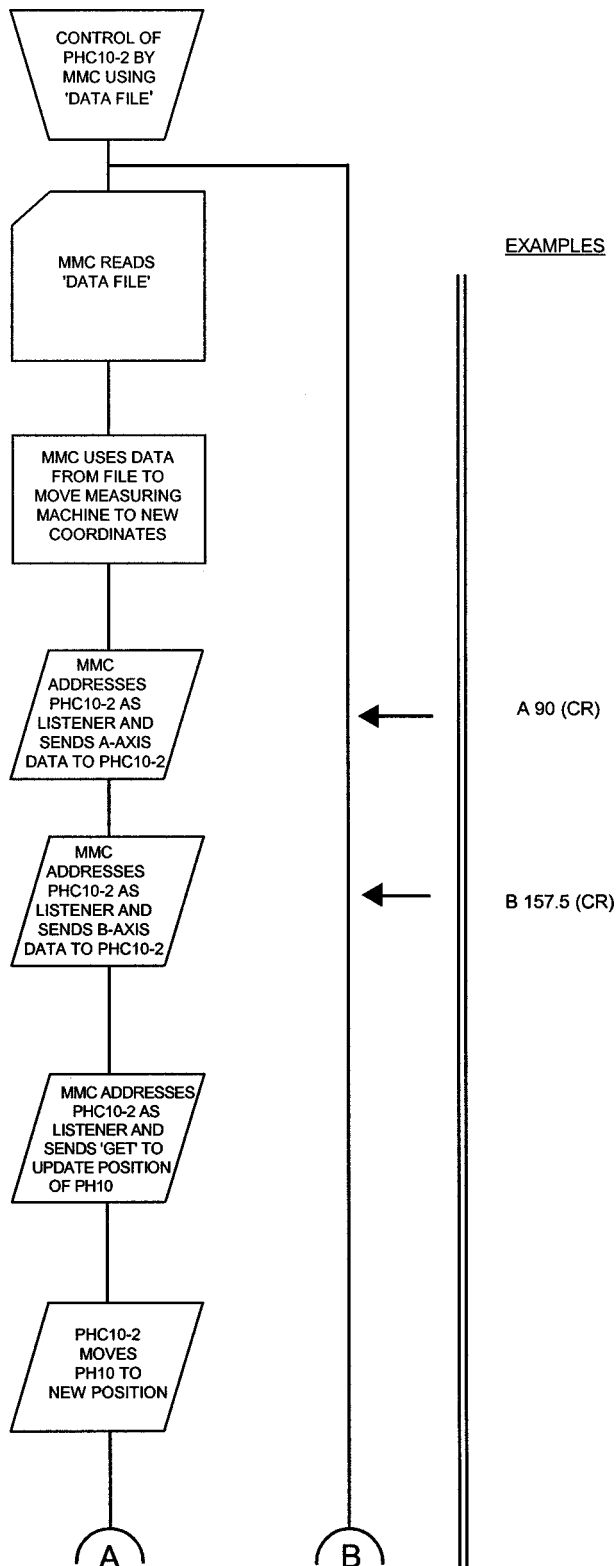

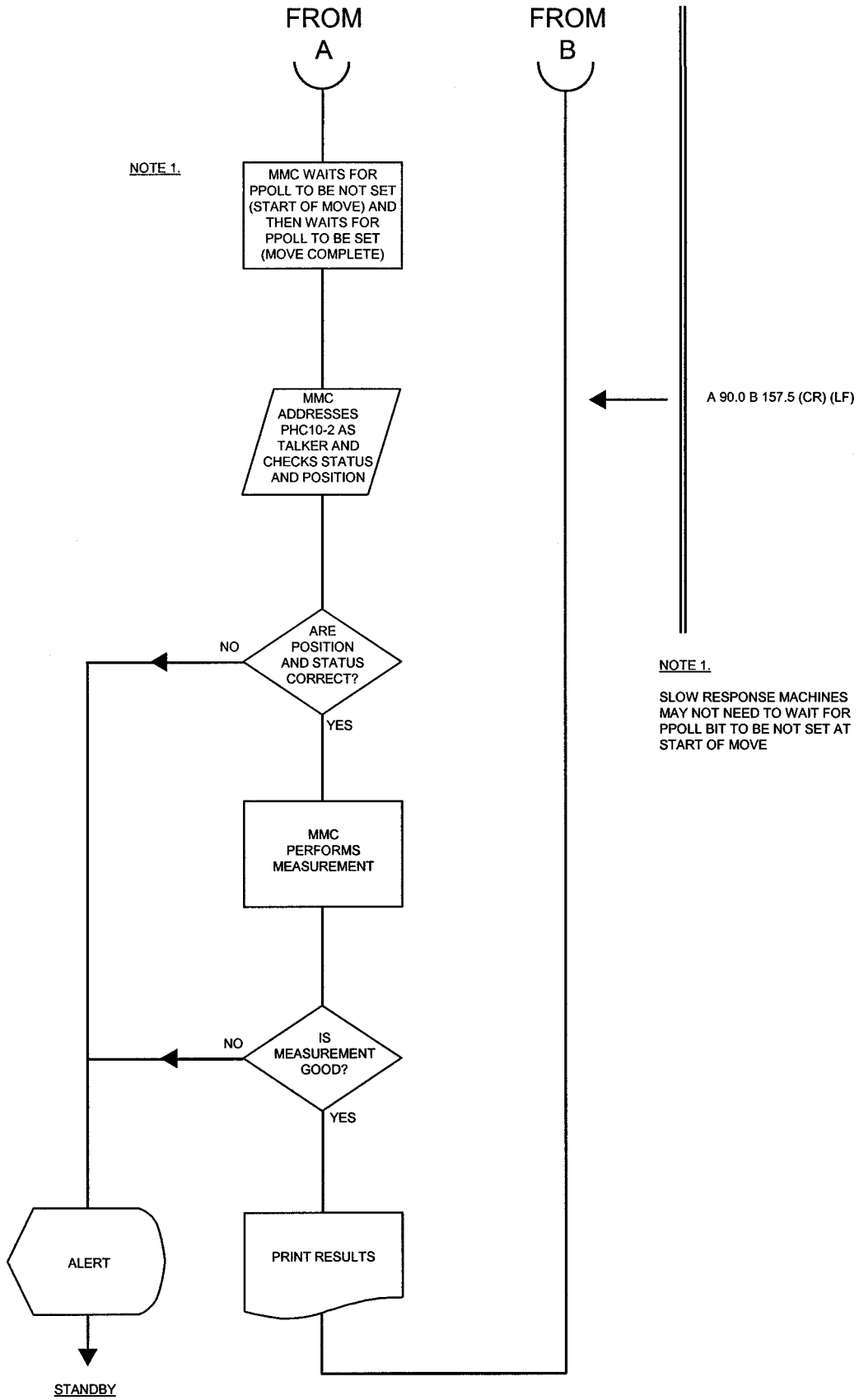

**FLOWCHART 18 - SUGGESTED OPERATION OF PHC10-2 : SERVICE REQUEST (SRQ) HANDLING BY MMC USING INTERRUPT**

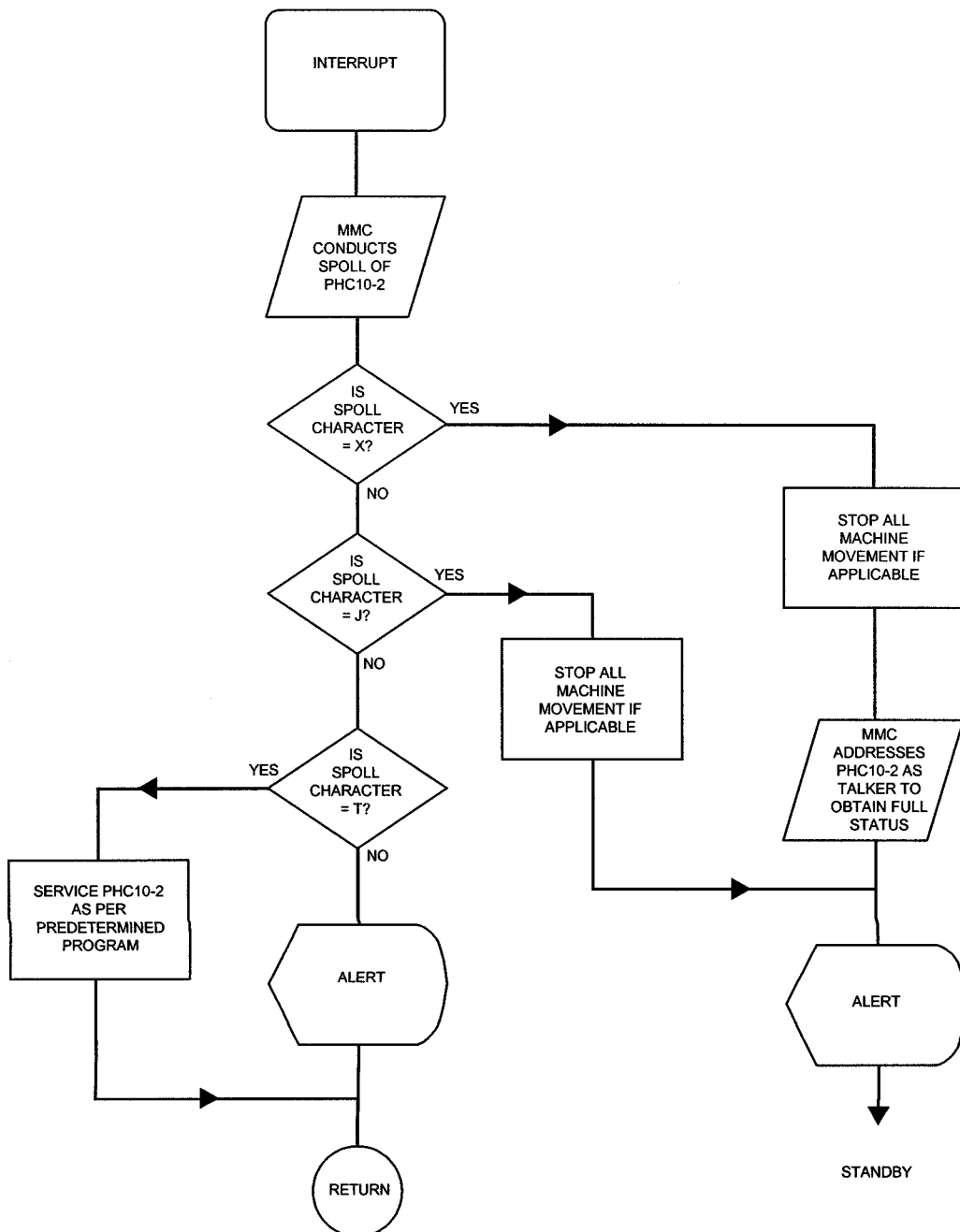

## Appendix

### Obstruct errors

The PHC10-2 software contains many routines which use time-outs to ensure that certain head operations are completed on time. If not, the operation is aborted and an obstruct error is signalled.

This will happen not only for a genuine obstruction (the head could not read its intended axis positions), but also for many other internal reasons (the lock motor failed, the head position could not be found at power up, etc).

Diagnostic software has been included in the PHC10-2 EPROM so that the cause of the last obstruct error may be identified. Each time an obstruct error is signalled, the PHC10-2 will store a code in its memory which uniquely identifies the reason for the error. Any previously stored code will be overwritten. Switching power off will cause the code to be lost.

With an HCU1 connected to the PHC10-2 and the system in manual mode, a two-digit code will be displayed in the HCU1 A-axis display when its T button is pressed.

The following pages show the interpretation of the codes.



FIND OBSTRUCT ERROR CODES

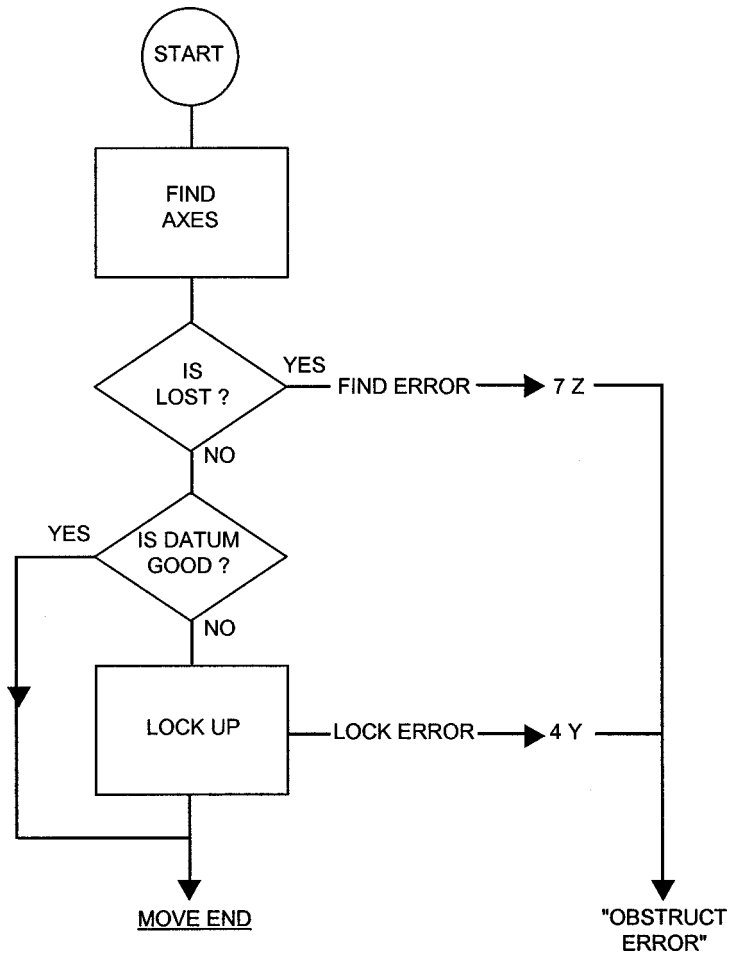

X = UNLOCK REASON	
1	25ms TIMEOUT WAITING FOR 3ms DEBOUNCED STARTUP PEAK HI
8	3ms TIMEOUT WAITING FOR END OF STARTUP PEAK AFTER 300ms
9	LOCK CURRENT WAS HI FOR 3ms DURING 150ms UNLOCK TIME OR WAS HI AT END OF 150ms
Y = LOCK REASON	
1	25ms TIMEOUT WAITING FOR 3ms DEBOUNCED STARTUP PEAK HI
2	3s TIMEOUT WAITING FOR CAM PEAK
3	3s TIMEOUT DURING 3ms CAM PEAK DEBOUNCE
4	900ms TIMEOUT WAITING FOR SECOND 3ms CAM PEAK HI
5	900ms TIMEOUT DURING SECOND 3ms CAM PEAK DEBOUNCE
6	900ms TIMEOUT WAITING FOR CAM PEAK END
7	900ms TIMEOUT DURING 3ms CAM PEAK END DEBOUNCE
Z = FIND REASON	
1	AXIS A LOST AFTER "SLOWAFIND" ROUTINE
2	AXIS B LOST AFTER "SLOWBFIND" ROUTINE
3	BOTH AXES LOST

AUTO MOVE

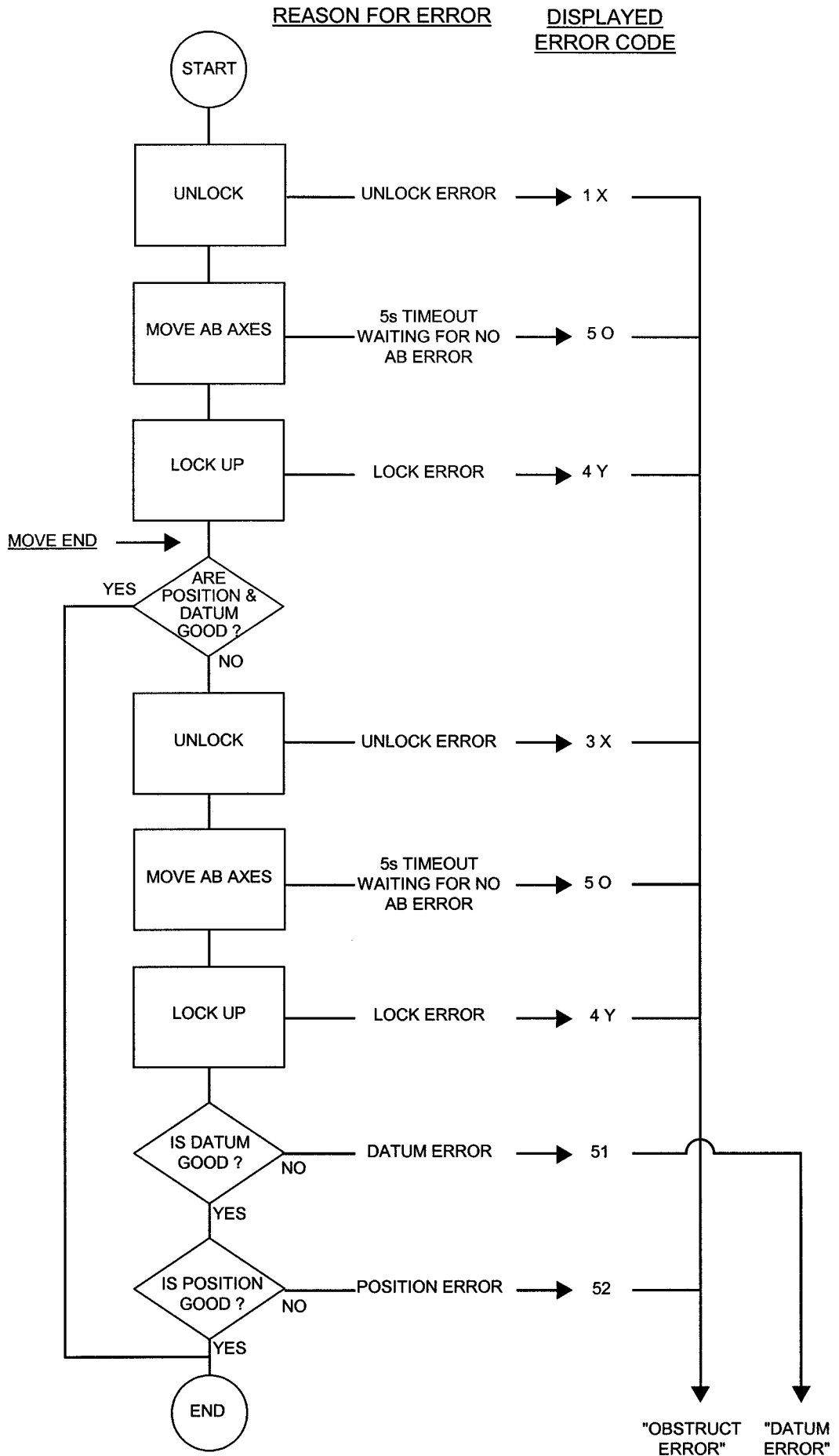

MANUAL MOVE

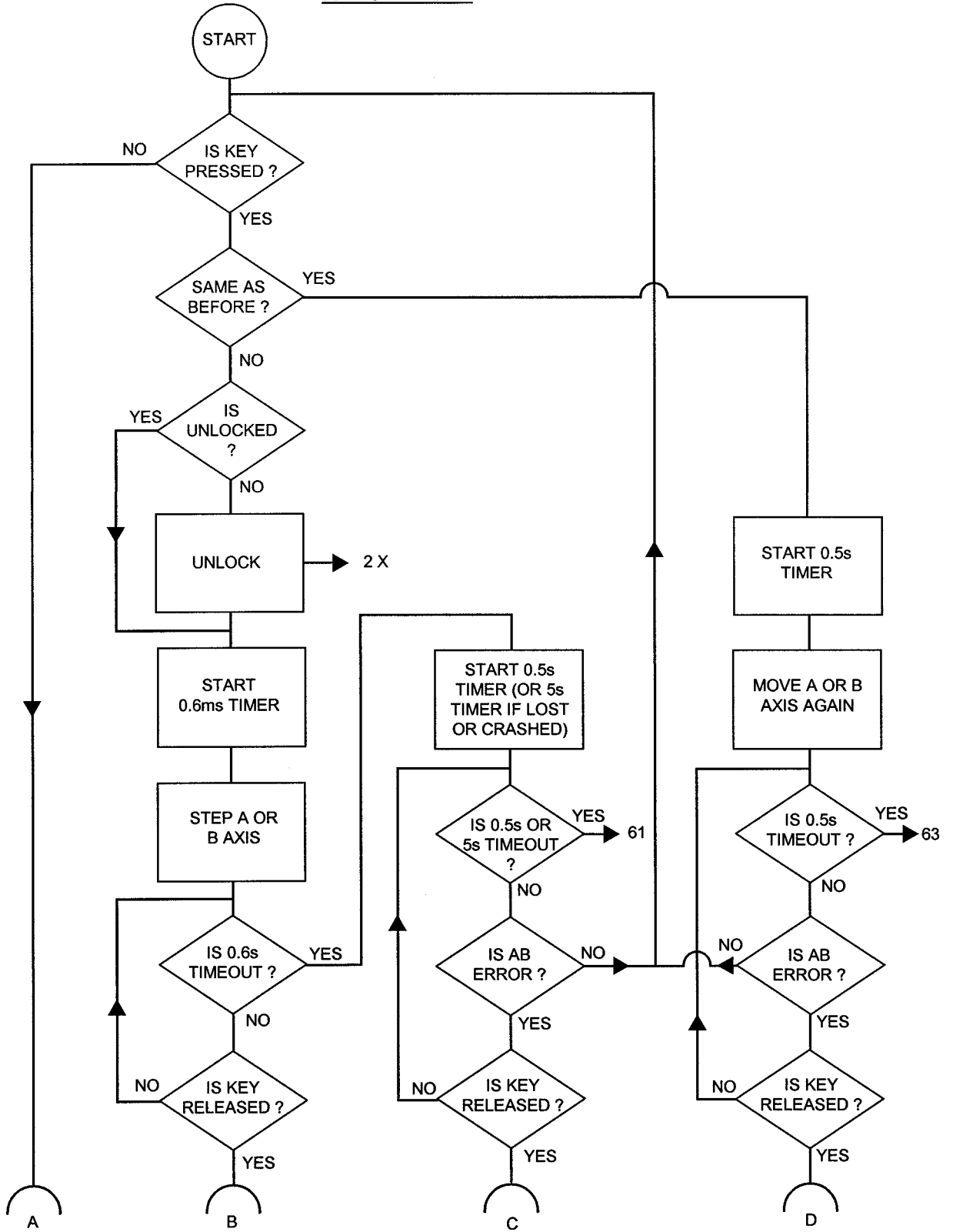

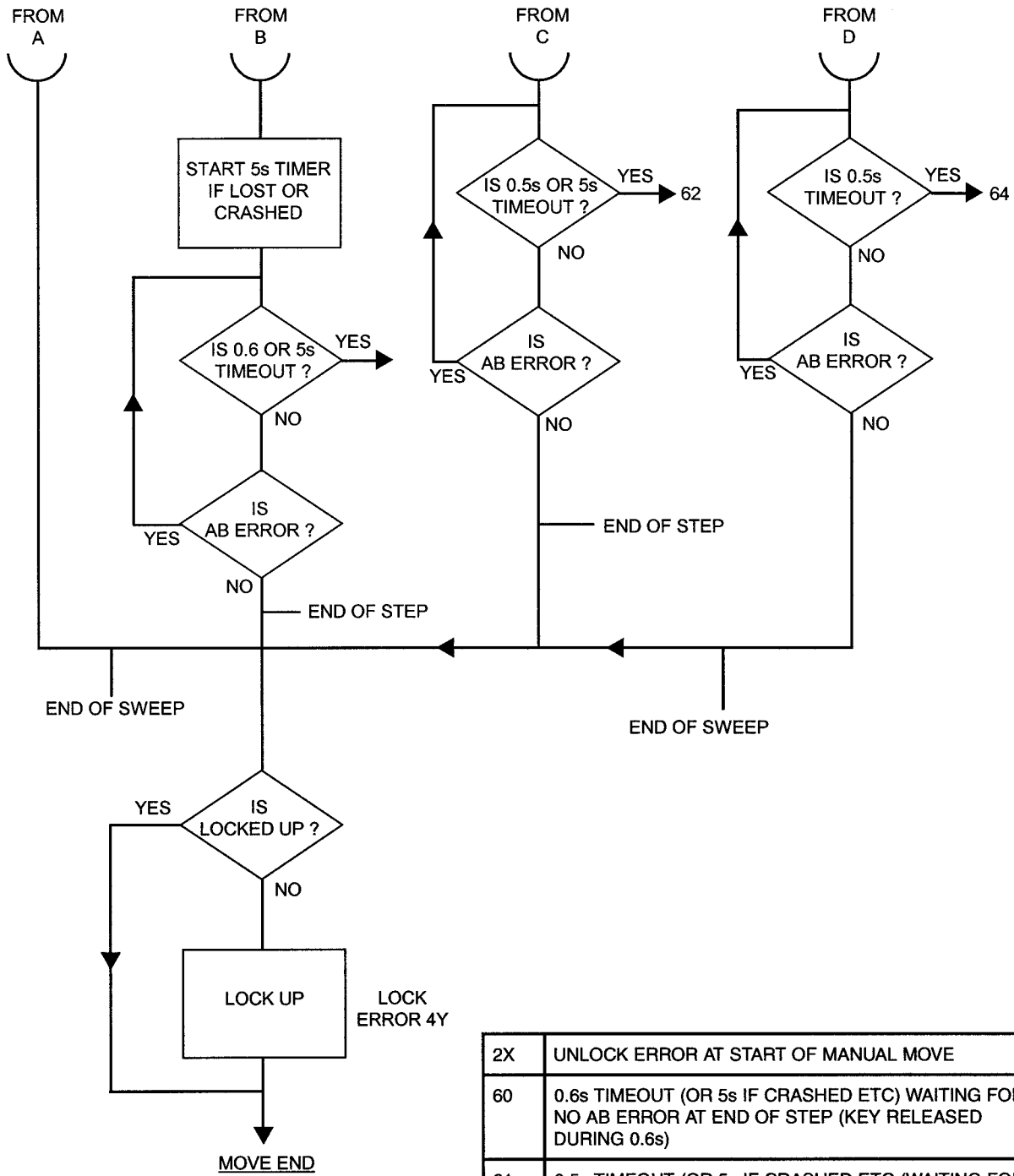

2X	UNLOCK ERROR AT START OF MANUAL MOVE
60	0.6s TIMEOUT (OR 5s IF CRASHED ETC) WAITING FOR NO AB ERROR AT END OF STEP (KEY RELEASED DURING 0.6s)
61	0.5s TIMEOUT (OR 5s IF CRASHED ETC) WAITING FOR NO AB ERROR AT END OF STEP (KEY STILL PRESSED)
62	0.5s TIMEOUT (OR 5s IF CRASHED ETC) WAITING FOR NO AB ERROR AT END OF STEP (KEY RELEASED)
63	0.5s TIMEOUT WAITING FOR NO AB ERROR DURING SWEEP (KEY STILL PRESSED)
64	0.5s TIMEOUT WAITING FOR NO AB ERROR DURING SWEEP (KEY RELEASED)
4Y	LOCK ERROR

