

TP8 user's guide

www.renishaw.com

TP8 user's guide

Documentation part number: H-1000-5118-04-D



TP8 user's guide

www.renishaw.com

General information

© 2006 - 2021 Renishaw plc. All rights reserved.

 ORIGINAL LANGUAGE VERSION

This document may not be copied or reproduced in whole or in part, or transferred to any other media or language by any means, without the prior written permission of Renishaw.

Disclaimer

WHILE CONSIDERABLE EFFORT WAS MADE TO VERIFY THE ACCURACY OF THIS DOCUMENT AT PUBLICATION, ALL WARRANTIES, CONDITIONS, REPRESENTATIONS AND LIABILITY, HOWSOEVER ARISING, ARE EXCLUDED TO THE EXTENT PERMITTED BY LAW.

RENISHAW RESERVES THE RIGHT TO MAKE CHANGES TO THIS DOCUMENT AND TO THE EQUIPMENT, AND/OR SOFTWARE AND THE SPECIFICATION DESCRIBED HEREIN WITHOUT OBLIGATION TO PROVIDE NOTICE OF SUCH CHANGES.

Trade marks

RENISHAW[®], the probe symbol and REVO[®] are registered trade marks of Renishaw plc.

Renishaw product names, designations and the mark 'apply innovation' are trade marks of Renishaw plc or its subsidiaries.

Other brand, product or company names are trade marks of their respective owners.

WEEE



The use of this symbol on Renishaw products and / or accompanying documentation indicates that the product should not be mixed with general household waste upon disposal. It is the responsibility of the end user to dispose of this product at a designated collection point for waste electrical and electronic equipment (WEEE) to enable reuse or recycling. Correct disposal of this product will help to save valuable resources and prevent potential negative effects on the environment. For more information, please contact your local waste disposal service or Renishaw distributor.

Warranty

Unless you and Renishaw have agreed and signed a separate written agreement, the equipment and/or software are sold subject to the Renishaw Standard Terms and Conditions supplied with such equipment and/or software, or available on request from your local Renishaw office.

Renishaw warrants its equipment and software for a limited period (as set out in the Standard Terms and Conditions), provided that they are installed and used exactly as defined in associated Renishaw documentation. You should consult these Standard Terms and Conditions to find out the full details of your warranty.

Equipment and/or software purchased by you from a third-party supplier is subject to separate terms and conditions supplied with such equipment and/or software. You should contact your third-party supplier for details.

TP8 user's guide

www.renishaw.com

Care of equipment

Renishaw probes and associated systems are precision tools used for obtaining precise measurements and must therefore be treated with care.

Changes to Renishaw products

Renishaw reserves the right to improve, change or modify its hardware or software without incurring any obligations to make changes to Renishaw equipment previously sold.

Company registration details

Renishaw plc. Registered in England and Wales. Company no: 1106260. Registered office: New Mills, Wotton-under-Edge, Gloucestershire, GL12 8JR, UK.

Packaging

To aid end user recycling and disposal the materials used in the different components of the packaging are stated here:

Packaging component	Material	94/62/EC code	94/62/EC number
Outer box	Corrugated fibreboard	PAP	20
Packing foam	Polyurethane foam	PUR	113
Plastic bags	Low density Polyethylene	LDPE	4

TP8 user's guide

www.renishaw.com

Product compliance

EU declaration of conformity

Contact Renishaw plc or visit www.renishaw.com/EUCMM for the full EU declaration.

UK declaration of conformity

Contact Renishaw plc or visit www.renishaw.com/UKCMM for the full UK declaration.

EMC conformity

This equipment must be installed and used in accordance with this installation guide. This product is intended for industrial use only and should not be used in a residential area or connected to a low voltage power supply network which supplies buildings used for residential purposes.

ICES-001 (Canada only)

This ISM device complies with Canadian ICES-001.

Cet appareil ISM est conforme à la norme ICES-001 du Canada.

REACH regulation

Information required by Article 33(1) of Regulation (EC) No. 1907/2006 ("REACH") relating to products containing substances of very high concern (SVHCs) is available at:

www.renishaw.com/REACH

TP8 user's guide

www.renishaw.com

China RoHS

Contact Renishaw plc or visit www.renishaw.com/ChinaRoHSCMM for the full China RoHS tabulation.



Probe trigger force adjustment

i **NOTE:** Only increase the stylus trigger force if you encounter unexpected probe triggers.

The probe trigger force can be adjusted using a 2.5 mm hexagonal wrench. A clockwise rotation increases the trigger force from 0.1 N to 0.3 N approximately. Before leaving the factory, this force is set to 0.12 N based on a 21 mm long stylus fitted with a 4 mm diameter ball tip.

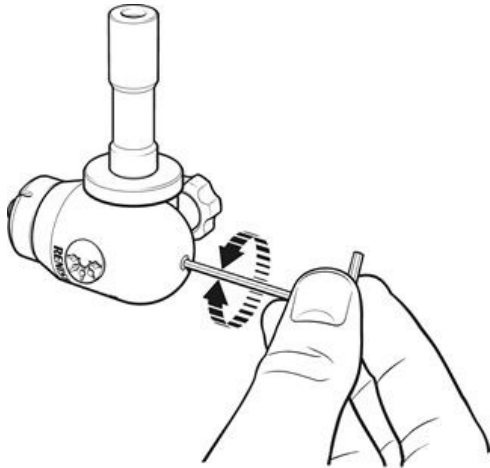

Dimensions

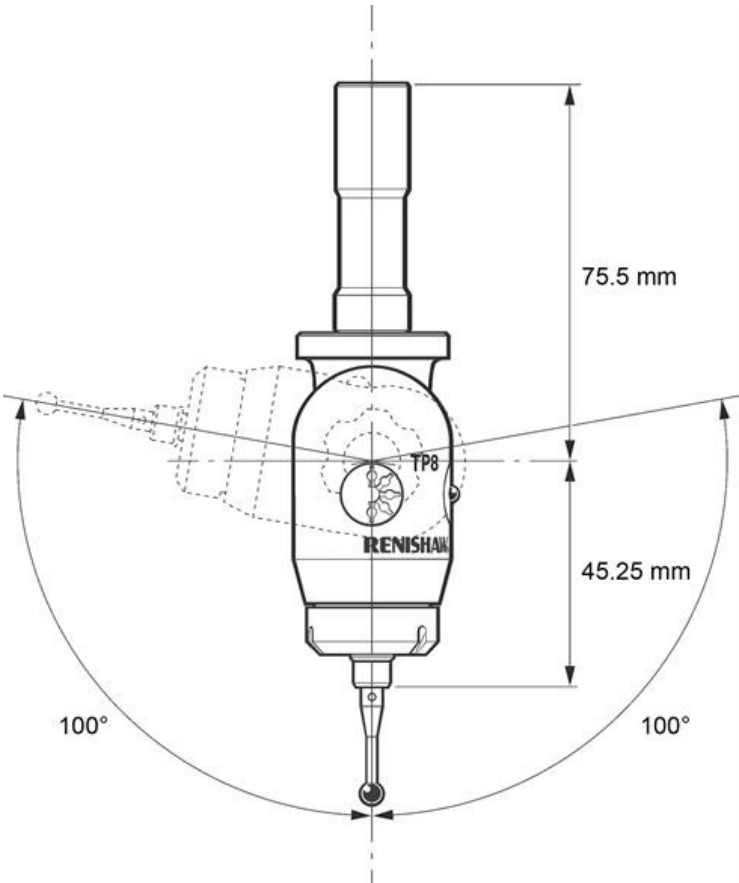

TP8 user's guide

www.renishaw.com

Specification

Principal application	Robust universal DCC and manual CMMs.
Sense directions	5-axis: $\pm X$, $\pm Y$, $+Z$
Unidirectional repeatability maximum (2σ μm) (at stylus tip)	0.5 μm (0.00002 in)
Pre-travel variation 360° (XY plane)	± 1 μm (± 0.00004 in)
Weight (without shank)	95 g (3.36 oz)
Stylus range	M3
Stylus force range (adjustable)	0.11 N - 0.3 N
Stylus force (set by Renishaw)	0.11 N - 0.13 N
Stylus overtravel (typical)	XY plane: $\pm 22^\circ$ +Z axis: 5.5 mm (0.22 in) @ 0.11 N 2 mm (0.08 in) @ 0.3 N
Mounting method	Shank
Suitable interface	PI 7-3, PI 200-3, UCC

Above data applies to test conditions as follows:

- Stylus length 21 mm (0.83 in)
- Stylus velocity 480 mm/min (1.57 ft/min)
- Stylus force 0.11 N to 0.13 N
- $\varnothing 4$ mm ball

Renishaw plc
New Mills, Wotton-under-Edge
Gloucestershire, GL12 8JR
United Kingdom

T +44 (0)1453 524524
F +44 (0)1453 524901
www.renishaw.com/cmmsupport



**For worldwide contact details,
please visit our main website at
www.renishaw.com/contact**