

RESM rotary scale



The RESM is a one-piece stainless steel ring with 20 or 40 μm scale marked directly onto the periphery, featuring the *IN-TRAC*™ auto-phase optical reference mark.

The RESM offers impressive accuracy with resolution to 0.00075 arc second, suiting the most demanding precision applications.

Read by Renishaw's VIONiC™, TONiC™ and QUANTiC™ encoder systems, it has high tolerance to dirt, scratches and greasy fingerprints that can cause other encoder systems to miscount.

The low profile RESM, with large internal diameter, is easy to design into most installations. Equally important, its low mass, low inertia design does not compromise system performance. Available in a wide range of sizes and line counts, providing compatibility with industry standard controllers.

- Compatible with the VIONiC, TONiC and QUANTiC encoder systems offering industry standard analogue or digital incremental outputs
- *IN-TRAC* bi-directional optical reference mark
- Graduation accuracy to ± 0.38 arc second (550 mm ring)
- Patented taper mount simplifies integration and minimises installation errors
- Large internal diameter for ease of integration
- Available in sizes from $\text{Ø}52$ mm to $\text{Ø}550$ mm with line counts from 4 096 to 86 400
- Custom sizes also available
- Low mass and low inertia
- Ultra-low inertia versions also available
- REST20 is a RESM20 with two reference marks, for use on dual readhead systems in partial arc applications

Installation drawing ('A' section)

Dimensions and tolerances in mm

Section A-A

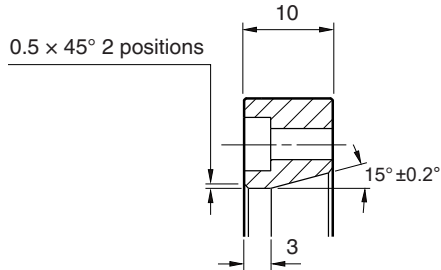

NOTE: θ is the angle between one tapped hole and the adjacent clearance hole. For example, the angle between two clearance holes is 2θ .

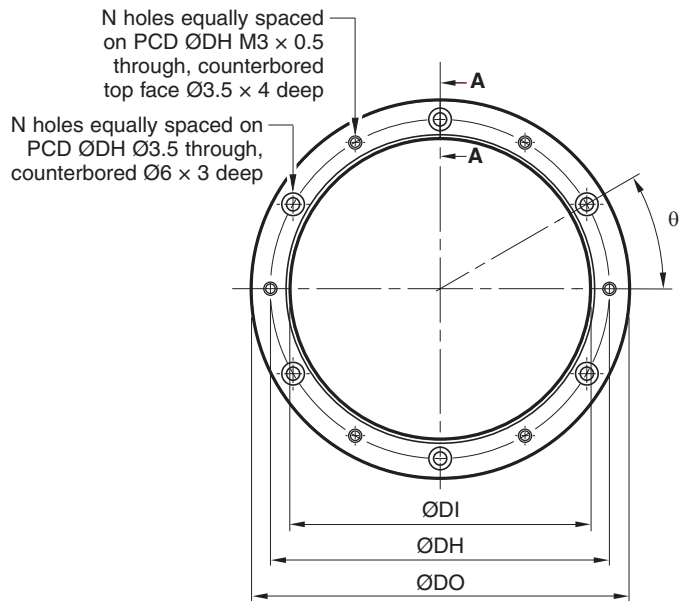

Nominal external diameter (mm)	Line count		DO (mm)	DI (mm)	Mounting holes		
	RESM20	RESM40			DH (mm)	N	θ
52	8 192	4 096	52.20 52.10	30.04 30.00	40	6	30°
57	9 000	4 500	57.35 57.25	37.04 37.00	47	6	30°
75	11 840	5 920	75.40 75.30	55.04 55.00	65	6	30°
100	15 744	7 872	100.30 100.20	80.04 80.00	90	6	30°
103	16 200	8 100	103.20 103.00	80.04 80.00	90	6	30°
104	16 384	8 192	104.40 104.20	80.04 80.00	90	6	30°
115	18 000	9 000	114.70 114.50	95.04 95.00	105	6	30°
150	23 600	11 800	150.40 150.20	130.04 130.00	140	9	20°
200	31 488	15 744	200.40 200.20	180.04 180.00	190	12	15°
206	32 400	16 200	206.50 206.10	186.05 186.00	196	12	15°
209	32 768	16 384	208.80 208.40	186.05 186.00	196	12	15°
229	36 000	18 000	229.40 229.00	209.05 209.00	219	12	15°
255	40 000	20 000	254.80 254.40	235.06 235.00	245	12	15°
300	47 200	23 600	300.40 300.20	280.06 280.00	290	16	11.25°
350	55 040	27 520	350.40 350.20	330.06 330.00	340	16	11.25°
413	64 800	32 400	412.70 412.30	392.08 392.00	402	18	10°
417	65 536	32 768	417.40 417.00	380.10 380.00	390	18	10°
489	76 800	38 400	489.12 488.72	451.10 450.90	462	20	18°*
550	86 400	43 200	550.20 549.80	510.10 510.00	520	20	9°

*There are no tapped holes on the 489 mm ring.

Installation drawing ('B' section)

Dimensions and tolerances in mm

Section A-A

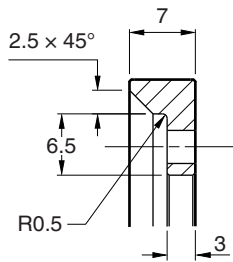

NOTE: θ is the angle between one tapped hole and the adjacent clearance hole. For example, the angle between two clearance holes is 2θ .

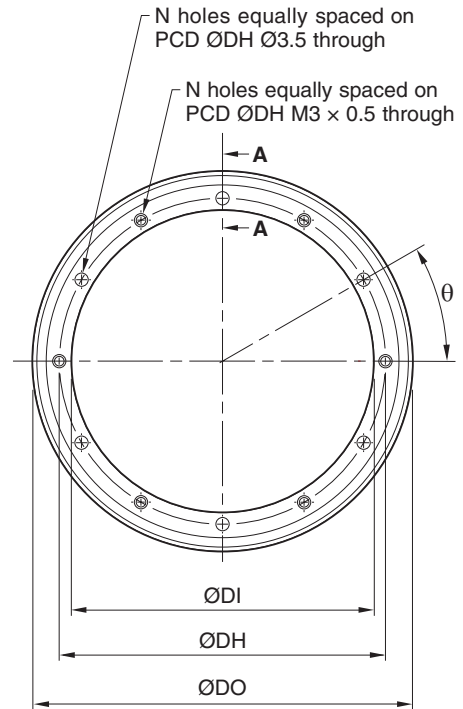

Nominal external diameter (mm)	Line count		DO (mm)	DI (mm)	DH (mm)	N	θ
	RESM20	RESM40					
52	8 192	4 096	52.20 52.10	32.04 32.00	38	6	30°
75	11 840	5 920	75.40 75.30	55.04 55.00	61	6	30°
100	15 744	7 872	100.30 100.20	80.04 80.00	86	6	30°
115	18 000	9 000	114.70 114.50	95.04 95.00	101	6	30°
150	23 600	11 800	150.40 150.20	130.04 130.00	136	9	20°
200	31 488	15 744	200.40 200.20	180.04 180.00	186	12	15°

Mounting methods

	Taper mount	Interference fit
'A' section		
'B' section	Not applicable	
Notes	<p>Recommended installation</p> <p>Offers highest accuracy. Enables simplest adjustment. Enables eccentricity to be compensated. Offers excellent mechanical stability against thermal cycling, shock and vibration. Minimises cost of substrate preparation.</p>	<p>Alternative installation</p> <p>Will not correct eccentricity of the supporting shaft.</p>

For further information on installation and mounting options, please refer to the relevant system installation guides, which are available from your local Renishaw representative, or can be downloaded from www.renishaw.com/encoderinstallationguides



Reference mark position



IN-TRAC reference mark is embedded in the scale, radially aligned with the centre of the mounting hole to the left of the 'Renishaw' logo, within ± 0.5 mm. No external actuators or physical adjustment are required.

NOTE: For REST20 rings the second reference mark is located 180° from the first reference mark.

Compatible readheads

	VIONiC	TONiC	QUANTiC
			
Scale type	RESM20/REST20	RESM20/REST20	RESM40
Pitch	20 μm	20 μm	40 μm
Outputs	Digital resolutions from 5 μm to 2.5 nm direct from the readhead	Analogue 1 Vpp. Digital resolutions from 5 μm to 1 nm from an interface.	Analogue 1 Vpp. Digital resolutions from 10 μm to 50 nm direct from the readhead.
SDE (typical)	> $\varnothing 135$ < ± 15 nm $\leq \varnothing 135$ < ± 20 nm	± 30 nm	> $\varnothing 135$ < ± 150 nm $\leq \varnothing 135$ < ± 80 nm*
Jitter (RMS)	down to 1.6 nm	down to 0.5 nm	down to 2.73 nm
Maximum speed	12 m/s	10 m/s	24 m/s*

*Digital variants.

Readhead features

- ▶ Filtering optics and Auto Gain Control for high reliability and solid Lissajous signals.
- ▶ Dynamic signal processing ensures ultra-low sub-divisional error (SDE).
Result: smoother scanning performance.
- ▶ High signal-to-noise ratio provides ultra-low jitter for optimum positional stability.
- ▶ Auto-phasing of *IN-TRAC* reference mark.
- ▶ Clocked outputs ensure optimised speed performance for all resolutions, for a wide variety of industry-standard controllers.
- ▶ DOP Dual output interfaces available to provide simultaneous analogue and digital outputs (TONiC systems only).

Operating specifications

Material	303/304 stainless steel
Coefficient of thermal expansion (at 20 °C)	15.5 ±0.5 µm/m/°C
Temperature	Storage -20 °C to +70 °C Operating 0 °C to +70 °C

Nominal external diameter (mm)	52	57	75	100	103	104	115	150	200	206	
Nominal internal diameter (mm)	30	37	55	80	80	80	95	130	180	186	
Line count	RESM20 (20 µm)	8 192	9 000	11 840	15 744	16 200	16 384	18 000	23 600	31 488	32 400
	RESM40 (40 µm)	4 096	4 500	5 920	7 872	8 100	8 192	9 000	11 800	15 744	16 200
Mass (kg)	'A' section	0.1	0.1	0.15	0.2	0.24	0.26	0.23	0.32	0.43	0.44
	'B' section	0.045	-	0.07	0.1	-	-	0.1	0.15	0.2	-
Moment of inertia (kg mm ²)	'A' section	46	61	161	425	525	561	644	1 580	3 930	4 320
	'B' section	22.5	-	80	202	-	-	296	741	1 820	-

Nominal external diameter (mm)	209	229	255	300	350	413	417	489	550	
Nominal internal diameter (mm)	186	209	235	280	330	392	380	451	510	
Line count	RESM20 (20 µm)	32 768	36 000	40 000	47 200	55 040	64 800	65 536	76 800	86 400
	RESM40 (40 µm)	16 384	18 000	20 000	23 600	27 520	32 400	32 768	38 400	43 200
Mass (kg)	'A' section	0.5	0.5	0.54	0.66	0.78	0.93	1.76	2.13	2.53
	'B' section	-	-	-	-	-	-	-	-	-
Moment of inertia (kg mm ²)	'A' section	4 960	6 000	8 110	14 000	22 600	37 800	70 400	118 000	179 000
	'B' section	-	-	-	-	-	-	-	-	-

Accuracy

Nominal external diameter (mm)	Graduation accuracy (arc second)	VIONiC system accuracy (arc second)	TONiC system accuracy (arc second)	QUANTiC system accuracy (arc second)
52	±3.97	±4.13	±4.20	±4.60
57	±3.62	±3.76	±3.84	±4.20
75	±2.75	±2.86	±2.92	±3.19
100	±2.06	±2.15	±2.19	±2.39
103	±2.00	±2.08	±2.12	±2.32
104	±1.98	±2.06	±2.10	±2.30
115	±1.79	±1.87	±1.90	±2.08
150	±1.38	±1.40	±1.46	±1.60
200	±1.03	±1.05	±1.09	±1.20
206	±1.00	±1.02	±1.06	±1.16
209	±0.99	±1.01	±1.05	±1.15
229	±0.90	±0.92	±0.95	±1.04
255	±0.81	±0.83	±0.86	±0.94
300	±0.69	±0.70	±0.73	±0.80
350	±0.59	±0.60	±0.62	±0.68
413	±0.50	±0.51	±0.53	±0.58
417	±0.49	±0.50	±0.52	±0.57
489	±0.42	±0.43	±0.45	±0.49
550	±0.38	±0.38	±0.40	±0.44

Graduation accuracy is the maximum difference between the angle measured by a single readhead and the true rotation of the encoder as graduated. Application disturbances such as eccentricity are not included.

System accuracy is graduation accuracy plus SDE. Effects such as eccentricity influence installed accuracy. For application advice, please contact your local Renishaw representative.

Maximum speed (rev/min)

For details of maximum speeds for other clocked options, please contact your local Renishaw representative.

VIONiC system: For 50 MHz clocked option

Nominal external diameter (mm)	Line count	Output resolution											
		5 μm	1 μm	0.5 μm	0.2 μm	0.1 μm	50 nm	40 nm	25 nm	20 nm	10 nm	5 nm	2.5 nm
52	8 192	4 407	4 407	4 407	2 663	1 332	666	533	333	266	133	66	33
57	9 000	4 021	4 021	4 021	2 429	1 215	607	486	304	243	122	61	30
75	11 840	3 056	3 056	3 056	1 846	923	462	369	231	185	92	46	23
100	15 744	2 292	2 292	2 292	1 385	693	346	277	173	138	69	35	17
103	16 200	2 225	2 225	2 225	1 344	672	336	269	168	134	67	34	17
104	16 384	2 204	2 204	2 204	1 331	666	333	266	166	133	67	33	17
115	18 000	1 993	1 993	1 993	1 204	602	301	241	150	120	60	30	15
150	23 600	1 528	1 528	1 528	923	462	231	185	115	92	46	23	12
200	31 488	1 146	1 146	1 146	692	346	173	138	87	69	35	17	8.7
206	32 400	1 113	1 113	1 113	672	336	168	134	84	67	34	17	8.4
209	32 768	1 097	1 097	1 097	663	331	166	133	83	66	33	17	8.3
229	36 000	1 001	1 001	1 001	605	302	151	121	76	60	30	15	7.6
255	40 000	899	899	899	543	272	136	109	68	54	27	14	6.8
300	47 200	764	764	764	462	231	115	92	58	46	23	12	5.8
350	55 040	655	655	655	396	198	99	79	49	40	20	10	5.0
413	64 800	555	555	555	335	168	84	67	42	34	17	8.4	4.2
417	65 536	550	550	550	332	166	83	66	41	33	17	8.3	4.2
489	76 800	469	469	469	283	142	71	57	35	28	14	7.1	3.6
550	86 400	417	417	417	252	126	63	50	31	25	13	6.3	3.2

Maximum speed (rev/min)

For details of maximum speeds for other clocked options, please contact your local Renishaw representative.

TONiC system: For 50 MHz clocked option

Nominal external diameter (mm)	Line count	Output resolution										Analogue Ti0000	
		Ti0004 5 µm	Ti0020 1 µm	Ti0040 0.5 µm	Ti0100 0.2 µm	Ti0200 0.1 µm	Ti0400 50 nm	Ti1000 20 nm	Ti2000 10 nm	Ti4000 5 nm	Ti10KD 2 nm		Ti20KD 1 nm
52	8 192	3 673	3 673	3 673	2 380	1 190	597	238	119	59	24	12	3 673
57	9 000	3 351	3 351	3 351	2 171	1 086	544	217	109	54	22	11	3 351
75	11 840	2 546	2 546	2 546	1 650	825	414	165	83	41	17	8.1	2 546
100	15 744	1 910	1 910	1 910	1 238	619	310	124	62	31	12	6.1	1 910
103	16 200	1 854	1 854	1 854	1 202	601	301	120	60	30	12	5.9	1 854
104	16 384	1 836	1 836	1 836	1 190	595	298	119	59	30	12	5.9	1 836
115	18 000	1 661	1 661	1 661	1 076	538	270	108	54	27	11	5.3	1 661
150	23 600	1 273	1 273	1 273	825	413	207	83	41	21	8.3	4.1	1 273
200	31 488	955	955	955	619	309	155	62	31	15	6.2	3.1	955
206	32 400	927	927	927	601	300	151	60	30	15	6.0	3.0	927
209	32 768	914	914	914	592	296	148	59	30	15	5.9	2.9	914
229	36 000	834	834	834	540	270	136	54	27	14	5.4	2.7	834
255	40 000	749	749	749	485	243	122	49	24	12	4.9	2.4	749
300	47 200	637	637	637	413	206	103	41	21	10	4.1	2.0	637
350	55 040	546	546	546	354	177	89	35	18	8.8	3.5	1.7	546
413	64 800	462	462	462	300	150	75	30	15	7.5	3.0	1.5	462
417	65 536	458	458	458	297	148	74	30	15	7.4	3.0	1.5	458
489	76 800	391	391	391	253	127	63	25	13	6.3	2.5	1.2	391
550	86 400	347	347	347	225	113	56	23	11	5.6	2.3	1.1	347

Maximum speed (rev/min)

For details of maximum speeds for other clocked options, please contact your local Renishaw representative.

QUANTiC system: For 50 MHz clocked option

Nominal external diameter (mm)	Line count	Output resolution								Analogue 1 Vpp
		10 µm	5 µm	1 µm	0.5 µm	0.2 µm	0.1 µm	50 nm		
52	4 096	8 815	8 815	8 815	6 659	2 663	1 332	666	7 346	
57	4 500	8 042	8 042	8 042	6 075	2 429	1 215	607	6 701	
75	5 920	6 112	6 112	6 112	4 617	1 846	923	462	5 093	
100	7 872	4 584	4 584	4 584	3 463	1 385	693	346	3 820	
103	8 100	4 450	4 450	4 450	3 362	1 344	672	336	3 708	
104	8 192	4 407	4 407	4 407	3 329	1 331	666	333	3 673	
115	9 000	3 986	3 986	3 986	3 011	1 204	602	301	3 321	
150	11 800	3 056	3 056	3 056	2 308	923	462	231	2 546	
200	15 744	2 292	2 292	2 292	1 731	692	346	173	1 910	
206	16 200	2 225	2 225	2 225	1 681	672	336	168	1 854	
209	16 384	2 193	2 193	2 193	1 657	663	331	166	1 828	
229	18 000	2 002	2 002	2 002	1 512	605	302	151	1 668	
255	20 000	1 798	1 798	1 798	1 358	543	272	136	1 498	
300	23 600	1 528	1 528	1 528	1 154	462	231	115	1 273	
350	27 520	1 310	1 310	1 310	989	396	198	99	1 091	
413	32 400	1 110	1 110	1 110	838	335	168	84	925	
417	32 768	1 099	1 099	1 099	830	332	166	83	916	
489	38 400	937	937	937	708	283	142	71	781	
550	43 200	833	833	833	630	252	126	63	694	

Resolution

VIONiC with RESM20

The RESM20 offers a range of standard ring diameters, as well as sizes that offer line counts that provide 2ⁿ counts per revolution or resolutions that are precise sub-divisions of degrees or arc seconds.

NOTE: 1 arc second resolution = 1.296×10^6 counts per revolution $\approx 2.778 \times 10^{-4}$ degree resolution.

	Nominal external diameter (line count)	VIONiC digital resolution (interpolation factor)											
		5 μm (×4)	1 μm (×20)	0.5 μm (×40)	0.2 μm (×100)	0.1 μm (×200)	50 nm (×400)	40 nm (×500)	25 nm (×800)	20 nm (×1 000)	10 nm (×2 000)	5 nm (×4 000)	2.5 nm (×8 000)
Standard outside diameters	75 mm (11 840)	≈ 27.4"	≈ 5.47"	≈ 2.74"	≈ 1.1"	≈ 0.55"	≈ 0.27"	≈ 0.22"	≈ 0.14"	≈ 0.11"	≈ 0.055"	≈ 0.028"	≈ 0.014"
	100 mm (15 744)	≈ 20.6"	≈ 4.12"	≈ 2.06"	≈ 0.82"	≈ 0.41"	≈ 0.21"	≈ 0.16"	≈ 0.10"	≈ 0.082"	≈ 0.041"	≈ 0.021"	≈ 0.010"
	150 mm (23 600)	≈ 13.7"	≈ 2.75"	≈ 1.37"	≈ 0.55"	≈ 0.27"	≈ 0.14"	≈ 0.11"	≈ 0.07"	≈ 0.055"	≈ 0.028"	≈ 0.014"	≈ 0.007"
	200 mm (31 488)	≈ 10.3"	≈ 2.06"	≈ 1.03"	≈ 0.41"	≈ 0.21"	≈ 0.1"	≈ 0.08"	≈ 0.05"	≈ 0.041"	≈ 0.021"	≈ 0.010"	≈ 0.005"
	255 mm [†] (40 000)	≈ 8.1"	≈ 1.62"	≈ 0.81"	≈ 0.32"	≈ 0.16"	≈ 0.081"	≈ 0.06"	≈ 0.04"	≈ 0.032"	≈ 0.016"	≈ 0.0081"	≈ 0.004"
	300 mm (47 200)	≈ 6.9"	≈ 1.37"	≈ 0.69"	≈ 0.27"	≈ 0.14"	≈ 0.069"	≈ 0.05"	≈ 0.03"	≈ 0.027"	≈ 0.014"	≈ 0.0069"	≈ 0.003"
	350 mm (55 040)	≈ 5.9"	≈ 1.18"	≈ 0.59"	≈ 0.24"	≈ 0.12"	≈ 0.059"	≈ 0.05"	≈ 0.03"	≈ 0.024"	≈ 0.012"	≈ 0.0059"	≈ 0.003"
	489 mm (76 800)	≈ 4.22"	≈ 0.84"	≈ 0.42"	≈ 0.17"	≈ 0.084"	≈ 0.042"	≈ 0.03"	≈ 0.02"	≈ 0.017"	≈ 0.0084"	≈ 0.0042"	≈ 0.002"
	550 mm (86 400)	≈ 3.75"	≈ 0.75"	≈ 0.38"	≈ 0.15"	≈ 0.075"	≈ 0.38"	≈ 0.03"	≈ 0.02"	≈ 0.015"	≈ 0.075"	≈ 0.038"	≈ 0.002"
2 ⁿ line count	52 mm (8 192)	≈ 39.6"	≈ 7.9"	≈ 3.96"	≈ 1.58"	≈ 0.79"	≈ 0.4"	≈ 0.32"	≈ 0.20"	≈ 0.16"	≈ 0.079"	≈ 0.040"	≈ 0.020"
	104 mm (16 384)	≈ 19.8"	≈ 3.96"	≈ 1.98"	≈ 0.79"	≈ 0.4"	≈ 0.2"	≈ 0.16"	≈ 0.10"	≈ 0.08"	≈ 0.040"	≈ 0.020"	≈ 0.010"
	209 mm (32 768)	≈ 9.89"	≈ 1.98"	≈ 0.99"	≈ 0.4"	≈ 0.2"	≈ 0.1"	≈ 0.8"	≈ 0.05"	≈ 0.04"	≈ 0.02"	≈ 0.0099"	≈ 0.005"
	417 mm (65 536)	≈ 4.9"	≈ 0.99"	≈ 0.49"	≈ 0.2"	≈ 0.1"	≈ 0.05"	≈ 0.04"	≈ 0.02"	≈ 0.02"	≈ 0.0099"	≈ 0.0049"	≈ 0.002"
Subdivisions of degrees	57 mm (9 000)	0.01°	0.002°	0.001°	0.0004°	0.0002°	0.0001°	0.00008°	0.00005°	0.00004°	0.00002°	0.00001°	0.000005°
	115 mm (18 000)	0.005°	0.001°	0.0005°	0.0002°	0.0001°	0.00005°	0.00004°	0.00003°	0.00002°	0.00001°	0.000005°	0.000003°
	229 mm (36 000)	0.0025°	0.0005°	0.00025°	0.0001°	0.00005°	0.000025°	0.00002°	0.00001°	0.00001°	0.000005°	0.0000025°	0.000001°
Subdivisions of arc second	103 mm (16 200)	20"	4"	2"	0.8"	0.4"	0.2"	0.16"	0.10"	0.08"	0.040"	0.020"	0.010"
	206 mm (32 400)	10"	2"	1"	0.4"	0.2"	0.1"	0.08"	0.05"	0.04"	0.020"	0.010"	0.0050"
	413 mm (64 800)	5"	1"	0.5"	0.2"	0.1"	0.05"	0.04"	0.03"	0.02"	0.010"	0.0050"	0.003"

[†]Line count as a multiple of 1000.

NOTE: The symbol " indicates units of arc seconds.

NOTE: Numbers preceded with a ≈ symbol show rounded resolution values. To calculate the exact resolution in arc seconds, use the following equation:

$$\theta \text{ (arc seconds)} = \frac{1.296 \times 10^6}{[\text{Line count}] \times [\text{Interpolation factor}]}$$

Resolution

TONiC with RESM20

The RESM20 offers a range of standard ring diameters, as well as sizes that offer line counts that provide 2ⁿ counts per revolution or resolutions that are precise sub-divisions of degrees or arc seconds.

NOTE: 1 arc second resolution = 1.296 × 10⁶ counts per revolution ≈ 2.778 × 10⁻⁴ degree resolution.

	Nominal external diameter (line count)	TONiC digital resolution (interpolation factor)										
		5 μm (×4)	1 μm (×20)	0.5 μm (×40)	0.2 μm (×100)	0.1 μm (×200)	50 nm (×400)	20 nm (×1 000)	10 nm (×2 000)	5 nm (×4 000)	2 nm (×10 000)	1 nm (×20 000)
Standard outside diameters	75 mm (11 840)	≈ 27.4"	≈ 5.47"	≈ 2.74"	≈ 1.1"	≈ 0.55"	≈ 0.27"	≈ 0.11"	≈ 0.055"	≈ 0.028"	≈ 0.011"	≈ 0.0055"
	100 mm (15 744)	≈ 20.6"	≈ 4.12"	≈ 2.06"	≈ 0.82"	≈ 0.41"	≈ 0.21"	≈ 0.082"	≈ 0.041"	≈ 0.021"	≈ 0.0082"	≈ 0.0041"
	150 mm (23 600)	≈ 13.7"	≈ 2.75"	≈ 1.37"	≈ 0.55"	≈ 0.27"	≈ 0.14"	≈ 0.055"	≈ 0.028"	≈ 0.014"	≈ 0.0055"	≈ 0.0027"
	200 mm (31 488)	≈ 10.3"	≈ 2.06"	≈ 1.03"	≈ 0.41"	≈ 0.21"	≈ 0.1"	≈ 0.041"	≈ 0.021"	≈ 0.010"	≈ 0.0041"	≈ 0.0020"
	255 mm [†] (40 000)	≈ 8.1"	≈ 1.62"	≈ 0.81"	≈ 0.32"	≈ 0.16"	≈ 0.081"	≈ 0.032"	≈ 0.016"	≈ 0.0081"	≈ 0.0032"	≈ 0.0016"
	300 mm (47 200)	≈ 6.9"	≈ 1.37"	≈ 0.69"	≈ 0.27"	≈ 0.14"	≈ 0.069"	≈ 0.027"	≈ 0.014"	≈ 0.0069"	≈ 0.0027"	≈ 0.0014"
	350 mm (55 040)	≈ 5.9"	≈ 1.18"	≈ 0.59"	≈ 0.24"	≈ 0.12"	≈ 0.059"	≈ 0.024"	≈ 0.012"	≈ 0.0059"	≈ 0.0024"	≈ 0.0012"
	489 mm (76 800)	≈ 4.22"	≈ 0.84"	≈ 0.42"	≈ 0.17"	≈ 0.084"	≈ 0.042"	≈ 0.017"	≈ 0.0084"	≈ 0.0042"	≈ 0.0017"	≈ 0.00084"
	550 mm (86 400)	≈ 3.75"	≈ 0.75"	≈ 0.38"	≈ 0.15"	≈ 0.075"	≈ 0.38"	≈ 0.015"	≈ 0.075"	≈ 0.038"	≈ 0.0015"	≈ 0.00075"
2 ⁿ line count	52 mm (8 192)	≈ 39.6"	≈ 7.9"	≈ 3.96"	≈ 1.58"	≈ 0.79"	≈ 0.4"	≈ 0.16"	≈ 0.079"	≈ 0.040"	≈ 0.016"	≈ 0.0079"
	104 mm (16 384)	≈ 19.8"	≈ 3.96"	≈ 1.98"	≈ 0.79"	≈ 0.4"	≈ 0.2"	≈ 0.08"	≈ 0.040"	≈ 0.020"	≈ 0.0080"	≈ 0.0040"
	209 mm (32 768)	≈ 9.89"	≈ 1.98"	≈ 0.99"	≈ 0.4"	≈ 0.2"	≈ 0.1"	≈ 0.04"	≈ 0.02"	≈ 0.0099"	≈ 0.0040"	≈ 0.0020"
	417 mm (65 536)	≈ 4.9"	≈ 0.99"	≈ 0.49"	≈ 0.2"	≈ 0.1"	≈ 0.05"	≈ 0.02"	≈ 0.0099"	≈ 0.0049"	≈ 0.0020"	≈ 0.00099"
Subdivisions of degrees	57 mm (9 000)	0.01°	0.002°	0.001°	0.0004°	0.0002°	0.0001°	0.00004°	0.00002°	0.00001°	0.000004°	0.000002°
	115 mm (18 000)	0.005°	0.001°	0.0005°	0.0002°	0.0001°	0.00005°	0.00002°	0.00001°	0.000005°	0.000002°	0.000001°
	229 mm (36 000)	0.0025°	0.0005°	0.00025°	0.0001°	0.00005°	0.000025°	0.00001°	0.000005°	0.0000025°	0.000001°	0.0000005°
Subdivisions of arc second	103 mm (16 200)	20"	4"	2"	0.8"	0.4"	0.2"	0.08"	0.040"	0.020"	0.0080"	0.0040"
	206 mm (32 400)	10"	2"	1"	0.4"	0.2"	0.1"	0.04"	0.020"	0.010"	0.0040"	0.0020"
	413 mm (64 800)	5"	1"	0.5"	0.2"	0.1"	0.05"	0.02"	0.010"	0.0050"	0.0020"	0.0010"

[†]Line count as a multiple of 1 000.

NOTE: The symbol " indicates units of arc seconds.

NOTE: Numbers preceded with a ≈ symbol show rounded resolution values. To calculate the exact resolution in arc seconds, use the following equation:

$$\theta \text{ (arc seconds)} = \frac{1.296 \times 10^6}{[\text{Line count}] \times [\text{Interpolation factor}]}$$

Resolution

QUANTiC with RESM40

The RESM40 offers a range of standard ring diameters, as well as sizes that offer line counts that provide 2ⁿ counts per revolution or resolutions that are precise sub-divisions of degrees or arc seconds.

NOTE: 1 arc second resolution = 1.296×10^6 counts per revolution $\approx 2.778 \times 10^{-4}$ degree resolution.

	Nominal external diameter (line count)	QUANTiC digital resolution (interpolation factor)						
		10 μm (x4)	5 μm (x8)	1 μm (x40)	0.5 μm (x80)	0.2 μm (x200)	0.1 μm (x400)	50 nm (x800)
Standard outside diameters	75 mm (5 920)	≈ 54.73"	≈ 27.36"	≈ 5.47"	≈ 2.74"	≈ 1.09"	≈ 0.55"	≈ 0.27"
	100 mm (7 872)	≈ 41.16"	≈ 20.58"	≈ 4.12"	≈ 2.06"	≈ 0.82"	≈ 0.41"	≈ 0.21"
	150 mm (11 800)	≈ 27.46"	≈ 13.73"	≈ 2.75"	≈ 1.37"	≈ 0.55"	≈ 0.27"	≈ 0.14"
	200 mm (15 744)	≈ 20.58"	≈ 10.29"	≈ 2.06"	≈ 1.03"	≈ 0.41"	≈ 0.21"	≈ 0.10"
	255 mm [†] (20 000)	≈ 16.20"	≈ 8.10"	≈ 1.62"	≈ 0.81"	≈ 0.32"	≈ 0.16"	≈ 0.08"
	300 mm (23 600)	≈ 13.73"	≈ 6.86"	≈ 1.37"	≈ 0.69"	≈ 0.27"	≈ 0.14"	≈ 0.07"
	350 mm (27 520)	≈ 11.77"	≈ 5.89"	≈ 1.18"	≈ 0.59"	≈ 0.24"	≈ 0.12"	≈ 0.06"
	489 mm (38 400)	≈ 8.44"	≈ 4.22"	≈ 0.84"	≈ 0.42"	≈ 0.17"	≈ 0.08"	≈ 0.04"
	550 mm (43 200)	≈ 7.50"	≈ 3.75"	≈ 0.75"	≈ 0.38"	≈ 0.15"	≈ 0.08"	≈ 0.04"
2 ⁿ line count	52 mm (4 096)	≈ 79.10"	≈ 39.55"	≈ 7.91"	≈ 3.96"	≈ 1.58"	≈ 0.79"	≈ 0.40"
	104 mm (8 192)	≈ 39.55"	≈ 19.78"	≈ 3.96"	≈ 1.98"	≈ 0.79"	≈ 0.40"	≈ 0.20"
	209 mm (16 384)	≈ 19.78"	≈ 9.89"	≈ 1.98"	≈ 0.99"	≈ 0.40"	≈ 0.20"	≈ 0.10"
	417 mm (32 768)	≈ 9.89"	≈ 4.94"	≈ 0.99"	≈ 0.49"	≈ 0.20"	≈ 0.10"	≈ 0.05"
Subdivisions of degrees	57 mm (4 500)	0.02°	0.01°	0.002°	0.001°	0.0004°	0.0002°	0.0001°
	115 mm (9 000)	0.01°	0.005°	0.001°	0.0005°	0.0002°	0.0001°	0.00005°
	229 mm (18 000)	0.005°	0.0025°	0.0005°	0.00025°	0.0001°	0.00005°	0.000025°
Subdivisions of arc second	103 mm (8 100)	40"	20"	4"	2"	0.8"	0.4"	0.2"
	206 mm (16 200)	20"	10"	2"	1"	0.4"	0.2"	0.1"
	413 mm (32 400)	10"	5"	1"	0.5"	0.2"	0.1"	0.05"

[†]Line count as a multiple of 1 000.

NOTE: The symbol " indicates units of arc seconds.

NOTE: Numbers preceded with a ≈ symbol show rounded resolution values. To calculate the exact resolution in arc seconds, use the following equation:

$$\theta \text{ (arc seconds)} = \frac{1.296 \times 10^6}{[\text{Line count}] \times [\text{Interpolation factor}]}$$

Rotary scale part numbers

RESM 20U S A 300

Rotary scale series

RESM - Single reference mark for axes capable of full rotation
 REST - Two reference marks for partial-rotation axes (20 µm pitch only)

Pitch

20U - 20 µm
 40U - 40 µm (RESM rotary scale series only)

Material

S - Stainless steel

Form

A - Tapered internal diameter
 B - Low inertia
 (only available in 52, 75, 100, 115, 150 and 200 mm diameters)

Diameter

052 - 52 mm	209 - 209 mm
057 - 57 mm	229 - 229 mm
075 - 75 mm	255 - 255 mm
100 - 100 mm	300 - 300 mm
103 - 103 mm	350 - 350 mm
104 - 104 mm	413 - 413 mm
115 - 115 mm	417 - 417 mm
150 - 150 mm	489 - 489 mm
200 - 200 mm	550 - 550 mm
206 - 206 mm	

RESM compatible readheads

RESM



RESM20

RESM40



VIONiC



TONiC



QUANTiC

For worldwide contact details, visit www.renishaw.com/contact

© 2004–2021 Renishaw plc. All rights reserved.
 RENISHAW® and the probe symbol are registered trade marks of Renishaw plc. Renishaw product names, designations and the mark 'apply innovation' are trade marks of Renishaw plc or its subsidiaries.
 Other brand, product or company names are trade marks of their respective owners.

WHILE CONSIDERABLE EFFORT WAS MADE TO VERIFY THE ACCURACY OF THIS DOCUMENT AT PUBLICATION, ALL WARRANTIES, CONDITIONS, REPRESENTATIONS AND LIABILITY, HOWSOEVER ARISING, ARE EXCLUDED TO THE EXTENT PERMITTED BY LAW. RENISHAW RESERVES THE RIGHT TO MAKE CHANGES TO THIS DOCUMENT AND TO THE EQUIPMENT, AND/OR SOFTWARE AND THE SPECIFICATION DESCRIBED HEREIN WITHOUT OBLIGATION TO PROVIDE NOTICE OF SUCH CHANGES.

Renishaw plc. Registered in England and Wales. Company no: 1106260.
 Registered office: New Mills, Wotton-under-Edge, Gloucestershire, GL12 8JR, UK.



L - 9 5 1 7 - 9 1 5 4 - 0 8

Part no.: L-9517-9154-08-B
 Issued: 01.2021