

**RENISHAW**® 

**NC1 non-contact  
tool setting system  
Programming Guide  
(Fanuc compatible)**

© 2000 Renishaw. All rights reserved.

Renishaw® is a registered trademark of Renishaw plc.

This document may not be copied or reproduced in whole or in part, or transferred to any other media or language, by any means without the written prior permission of Renishaw.

The publication of material within this document does not imply freedom from the patent rights of Renishaw plc.

### **Disclaimer**

Considerable effort has been made to ensure that the contents of this document are free from inaccuracies and omissions.

However, Renishaw makes no warranties with respect to the contents of this document and specifically disclaims any implied warranties. Renishaw reserves the right to make changes to this document and to the product described herein without obligation to notify any person of such changes.

### **Trademarks**

All brand names and product names used in this document are trade names, service marks, trademarks, or registered trademarks of their respective owners.

Renishaw part no: H-2000-6187-02-A

Issued: December 2000

## Caution – Laser safety



The laser used in the Renishaw NC1 non-contact toolsetting system emits visible red light at a wavelength of 670nm and has a maximum power output of less than 1mW. It is a Class 2 product as defined by European and American laser safety standards (EN60825-1:1994 and US Code of Federal Regulations 21CFR1040).

When using the NC1 system:

- Do not stare directly into the laser beam. The beam may be viewed safely from the side.
- Ensure that the laser beam is not reflected into the eyes of another person via a mirror or other reflective surface.
- Do not expose skin to the laser beam for longer than is absolutely essential.
- When the system is not being used, cover the laser beam aperture with the sliding cover.

## Caution – Software safety



The software you have purchased is used to control the movements of a machine tool. It has been designed to cause the machine to operate in a specified manner under operator control, and has been configured for a particular combination of machine tool hardware and controller.

**Continued ...**

### Caution – software safety (cont'd)

Renishaw has no control over the exact program configuration of the controller with which the software is to be used, nor of the mechanical layout of the machine. Therefore, it is the responsibility of the person putting the software into operation to:

- ensure that all machine safety guards are in position and are correctly working before commencement of operation;
- ensure that any manual overrides are disabled before commencement of operation;
- verify that the program steps invoked by this software are compatible with the controller for which they are intended;
- ensure that any moves which the machine will be instructed to make under program control would not cause the machine to inflict damage upon itself or upon any person in the vicinity;
- be thoroughly familiar with the machine tool and its controller and know the location of all emergency stop switches.

### Related publications

When using the beam alignment cycle (macro O9860) you will also need to refer to the following Renishaw publication. This contains instructions on how to physically align the beam at the NC1 transmitter unit.

*NC1 Installation Guide and Parts List*  
(Renishaw Part No. H-2000-5048)

# Contents

<b>Renishaw NC1 tool setting system .....</b>	<b>5</b>
<b>Features of the NC1 software .....</b>	<b>6</b>
Measuring macro features .....	6
Calibration macro features .....	6
Service macro features .....	7
<b>Software memory requirements .....</b>	<b>7</b>
<b>Machine tool controllers supported .....</b>	<b>8</b>
<b>Tool-offset types supported .....</b>	<b>8</b>
Positive tool-offset applications .....	8
Negative tool-offset applications .....	9
Relative to a master tool with zero (0) tool-offset value. ....	9
<b>Measurement values used in this guide .....</b>	<b>10</b>
<b>Installing the software .....</b>	<b>10</b>
<b>Macro variables .....</b>	<b>10</b>
Calibration-data macro variables .....	11
Setting-data macro variables (O9760) .....	12
Common variables .....	18
Variables – changing the base number address .....	18
<b>Customising the macros .....</b>	<b>20</b>
Editing the measure move macro (O9762) .....	20
<b>Orientation of the NC1 system .....</b>	<b>21</b>
<b>Beam-find and measuring moves .....</b>	<b>22</b>
<b>Scatter tolerance checking .....</b>	<b>23</b>
<b>Beam alignment (macro O9860) .....</b>	<b>24</b>
<b>Calibrating the NC1 (macro O9861) .....</b>	<b>31</b>

<b>Tool length setting (macro O9862)</b> .....	<b>37</b>
<b>Tool radius/diameter setting (macro O9862)</b> .....	<b>42</b>
<b>Tool length and radius setting (macro O9862)</b> .....	<b>48</b>
<b>Cutting edge checking (macro O9862)</b> .....	<b>55</b>
<b>Broken tool detection – plunge checking (macro O9863)</b> .....	<b>60</b>
<b>Broken tool detection – radial checking (macro O9864)</b> .....	<b>65</b>
<b>Cutter radius and linear profile checking (macro O9865)</b> .....	<b>69</b>
<b>Temperature compensation tracking (macro O9861)</b> .....	<b>77</b>
<b>Error messages and alarms</b> .....	<b>82</b>
<b>Appendix A Haas controller settings</b> .....	<b>87</b>
Automatically-set calibration variables .....	87
<b>Appendix B Yasnac controller settings</b> .....	<b>89</b>
MX3 and J50 controllers .....	89
I80 and J300 controllers .....	89
<b>Appendix C Meldas controller settings</b> .....	<b>90</b>
<b>Appendix D Mazak controller settings</b> .....	<b>91</b>

## **Renishaw NC1 tool setting system**

This guide describes how to use the Renishaw NC1 non-contact tool setting system software.

The Renishaw NC1 is a laser-based non-contact tool setting system that provides high-speed/high-precision measurement of cutting tools on a machining centre under normal operating conditions.

As a tool is moved through the laser beam, the system detects when the beam is broken. Output signals sent to the controller allow the presence of a tool and the position of the tip, a tooth, or a cutting edge to be established.

The NC1 allows the following parameters to be established:

- Length and diameter of the cutting tool. Tools as small as 0.2 mm (0.008 in) diameter can be accurately measured.
- Detection of a broken tool.
- Detection of a broken tip or cutting edge, or excessive runout of a tool.
- Compensation for thermal changes in the machine tool.

# Features of the NC1 software

The NC1 software provides the following measuring and calibration features:

## Measuring macro features

Four measuring macros provide the following features:

- Macro O9862 – used for measuring the length and diameter of the cutting tool and for cutting edge checking.
- Macro O9863 – used for broken tool detection by plunge measurement. This is intended for use on vertical machining centres.
- Macro O9864 – used for broken tool detection by radial measurement. This is intended for use on horizontal machining centres.
- Macro O9865 – used for checking the radii and linear profile of the cutter.

## Calibration macro features

Two calibration macros provide the following features:

- Macro O9860 – used for aligning the laser beam, setting the provisional positions of the beam in the spindle and radial-measuring axes, and setting the measuring position along the beam.
- Macro O9861 – used for calibrating the positions of the laser beam in the spindle and radial-measuring axes, and for temperature compensation of the spindle and radial-measuring axes.



## Service macro features

The measuring and calibration macros are supported by the service macros listed below.

- Macro O9760 – used for the settings data.
- Macro O9761 – used for startup functions.
- Macro O9762 – used for the measuring routine.
- Macro O9763 – used for the G31 routine.
- Macro O9764 – used for the G0/G1 routine.
- Macro O9765 – used for the G2/G3 routine.
- Macro O9769 – used for error messages.

## Software memory requirements

NC1 system software requires approximately 20 Kb (50 metres) of part-program memory.

If your controller is short of memory, there is no need to load any of the macros listed below if you do not intend using them:

- Macro O9862 (tool setting routine) 3.0 Kb (7.5 metres) of memory.
- Macro O9863 (broken tool – plunge check) 1.0 Kb (2.5 metres) of memory.
- Macro O9864 (broken tool – radial check) 0.6 Kb (1.5 metres) of memory.
- Macro O9865 (checking cutter radii and linear profiles) 3.5 Kb (8.75 metres) of memory.

## Software memory requirements

You may also remove the following macro after you have finished running the beam alignment cycle:

- Macro O9860 (laser beam alignment routine) 1.0 Kb (2.5 metres) of memory.

## Machine tool controllers supported

NC1 system software is suitable for use on the following machine tool controllers:

- Fanuc 0, 6, 10 – 15, 16 – 21, and (i) versions (including those with macro 'A' keyboards but fitted with macro 'B' options).
- Haas
- Mazak Fusion 640
- Melder
- Yasnac MX3 and I80, J50 and J300

## Tool-offset types supported

### Positive tool-offset applications

The NC1 software is ideally suited to setting tools using positive tool-offset values that represent the physical length of the tool.

Throughout this programming guide, descriptions refer to positive tool-offset applications.

The software can also be used in applications where negative tool-offset values are used or where all tool-offset values are entered as  $\pm$  values relative to a master tool. These applications are described below.

## Negative tool-offset applications

The offset value entered is the distance the tool tip must be moved from the home position to reach the zero (0) position of the part program (air-gap method), rather than the physical length of the tool.

### Example

Home position, to the zero (0) position of the part program = -1000 mm.

A master calibration tool of 150 mm is used (offset register value = -850 mm).

The longest tool for the machine is 200 mm long.

The shortest tool for the machine is 50 mm long.

Variables #110 and #111 must be set in the setting-data macro (O9760). Set them as follows:

#110 = -800.0            Maximum length tool

#111 = -950.0            Minimum length tool

## Relative to a master tool with zero (0) tool-offset value.

The master tool-offset register is set to zero (0) and all other tool-offset registers are set as  $\pm$  values relative to the master tool.

### Example

Home position, to the zero (0) position of the part program = -1000 mm (but this is not important)

## Tool-offset types supported

A master calibration tool of 150 mm is used (offset register value = 0).

The longest tool for the machine is 200 mm long.

The shortest tool for the machine is 50 mm long.

Variables #110 and #111 must be set in the setting-data macro (O9760). Set them as follows:

#110 = 50.0                      Maximum length tool

#111 = -100.0                    Minimum length tool

## Measurement values used in this guide

Throughout this guide, metric units of measurement, i.e. millimetres, are used in the examples. The equivalent imperial measurements, i.e. inches, are shown in brackets.

## Installing the software

Before installing the NC1 software, read the guidelines contained in the ReadMe file on the software floppy disk.

## Macro variables

The following variables are used by the NC1 system software:

- #500-series macro variables, used for the calibration data and settings data.
- #100-series macro variables, used for the setting data.
- Local #1 to #31 macro variables, used for locally defined data.

Variable #120 is used to define the base number of the calibration data variables. This number can be changed to avoid conflicts with other software applications.

The default base number is 520. This should be suitable for most controllers, with the exception of the Haas controller. The standard tool setting software variable base number for the Haas controller is 550 (for details, see “Appendix A – Haas controller settings”).

If the default number is not suitable and needs to be changed, do this as described in “Variables – changing the base number address” later in this guide.

## Calibration-data macro variables

The following variables are set automatically during the calibration cycles:

- #520 (520 + 0) Z-axis position of the beam, when measured from the positive side of the beam.
- #521 (520 + 1) (Reserved)
- #522 (520 + 2) X or Y-axis position of the beam, when measured from the negative side of the beam.
- #523 (520 + 3) X or Y-axis position of the beam, when measured from the positive side of the beam.
- #524 (520 + 4) Position along the beam at which measurements are made.
- #525 (520 + 5) Dynamic position zone.
- #526 (520 + 6) Spindle (length-measuring) axis temperature compensation work offset.

- #527 (520 + 7) Radial-measuring axis temperature compensation work offset.

## Setting-data macro variables (O9760)

Read the following variable descriptions then edit macro O9760 as described.

---

**NOTE:** #108 options are suitable for Fanuc controllers. For details of setting options suitable for other controllers, see the appropriate appendix at the end of this guide.

---

- #107 The unit used for setting data in macro O9760.  
1 = mm, 0.04 = inch  
**Default:** 1 (mm)
- #108 Tool offset type (1 = A, 2 = B, or 3 = C).  
**Default:** 1
- #109 Setting for tool offset type, either radius or diameter.  
1 = Radius, 2 = Diameter  
**Default:** 1
- #110 Maximum length of the tool. This defines the rapid approach height of the spindle nose above the laser beam.
- #111 Minimum length of the tool. This defines the lowest measuring height of the spindle nose above the laser beam.
- #112 Maximum diameter of the tool. This value is dependent on the machine tool.

#113 Radial-measuring axis options.

- 1 = measure from positive side of the beam,
- 1 = measure from negative side of the beam,
- 2 = measure from both sides of the beam.

**Default:** 2

#114 Radial calibration options.

- 1 = measure from positive side of the beam,
- 1 = measure from negative side of the beam,
- 2 = measure from both sides of the beam.

**Default:** 2.

#115 Hardware signal pulse time.

The time that the trigger signal is held on. This is hardware-dependent. The value is specified when the NC1 system is ordered.

Check the status LED sequence on power up (for details, see *"NC1 Installation Guide and Parts List"*).

#117 Default overtravel distance and radial clearance.

Overtravel is the distance through the beam that the tool is permitted to move before a Beam Not Cut alarm is initiated. Radial clearance is the distance between the tool and the beam when moving down the side of the beam.

**Default:** 5 mm (0.197 in)

#118 Default measurement resolution (feedrate-per-rev.). Typically 0.002 mm (0.0001 in) feed per revolution.

The larger the value, the less accurate measurements will be.

**Default:** 0.002 mm (0.0001 in)

#119 Default spindle speed.

Measurement cycles are optimised for a spindle speed of 3150 rev/min.

Some tools, e.g. those that are unbalanced or large, must be run at speeds less than 3150 rev/min. This is the responsibility of the user. Use the 'S' input to set speed.

Measurement cycle times increase with slower speeds. The minimum speed is 800 rev/min.

**Default value:** 3150 rev/min

#120 Base number for #500-series calibration data.

For a description of how to change this number, see "Variables – changing the base number address".

**Default:** #520

#121 Beam axis.

- If the laser beam is parallel to the X-axis, select 1.
- If the laser beam is parallel to the Y-axis, select 2.
- If the laser beam is parallel to the Z-axis, select 3.

#122 Axis used for radial measurement.

- If the X-axis is to be used for radial measurement, select 1.
- If the Y-axis is to be used for radial measurement, select 2.
- If the Z-axis is to be used for radial measurement, select 3.

**Default:** 2



- #123 Axis used for length measurement, i.e. the spindle axis.
- If the X-axis is to be used for length measurement, select 1.
  - If the Y-axis is to be used for length measurement, select 2.
  - If the Z-axis is to be used for length measurement, select 3.

**Default:** 3

---

**NOTE:** #123 must always define the spindle axis and the direction in which the tool offset is applied. If the spindle is in the negative direction, the value entered must also be negative (-1 = -X axis, -2 = -Y axis, -3 = -Z axis).

---

- #124 Scatter tolerance value.

For a description of this feature, see the figure in “Scatter tolerance checking”.

**Default:** 0.010 mm (0.0004 in)

- #125 Tolerance value for tool runout or cutting edge.

**Default:** 0.025 mm (0.001 in)

- #126 Sample size for scatter.

The number of measurement samples to be taken.

The number of retry attempts is twice this value.

For a description of this feature, see the figure in “Scatter tolerance checking”.

**Default:** 3

## Setting-data macro variables

#127 Rapid traverse feedrate.

**Default:** 5000 mm/min

#128 Select language.

1 = English, 2 = German, 3 = French, 4 = Italian

#145 Static position zone.

This zone value is used for checking whether the beam is already cut or was cut at the beginning of the measurement move. This avoids capturing bad data. The Active Beam Cut alarm is raised by this condition.

**Default:** 0.005 mm (0.0002 in)

#528 (520 + 8)

M code number to disable the latch mode. If the latch mode is not being used, leave this input as supplied unless the setting causes problems. If problems are encountered, use M9 coolant off (or similar).

#529 (520 + 9)

M code number to enable the latch mode. If the latch mode is not being used, leave this input as supplied unless the setting causes problems. If problems are encountered, use M9 coolant off (or similar).

### Editing the setting-data macro (O9760)

Before running the cycles, edit the settings data between block numbers N1 and N2 to suit the application and set up .

First, enter the metric/inch units factor (1. or .04) in variable #107.

Next, enter data in the other variables using the same units.



## **CAUTION: Variables #110 and #111**

Before running any cycles, valid data that is relevant to the machine tool must be entered for variables #110 and #111 (maximum and minimum tool length). There is a danger of the tool colliding with the NC1 unit if these values are incorrect.

## **Sample of macro O9760**

N1

#107=1. (UNITS FOR DATA 1MM .04INCH)

#108=1(TOOL OFFSET TYPE)

#109=1(OFFSET – RADIUS 1/DIAMETER 2)

#110=200.(MAX TOOL LENGTH) (8.0 in)

#111=70.(MIN TOOL LENGTH) (2.75 in)

#112=80.(MAX CUTTER DIAMETER) (3.15 in)

#113=2.(TL SET RADIUS MEAS DIR)

#114=2.(CALIB RADIUS MEAS DIR)

#115=.05(NC1 – DELAY IN SECS)

#117=5.(DEFAULT OVERTRAVEL) (0.197 in)

#118=.002(MEASURE RESOLUTION) (0.0001 in)

#119=3150(DEFAULT RPM)

#120=520(BASE NUMBER)

#121=1(BEAM AXIS)

#122=2(RADIAL-MEASURE AXIS)

#123=3(SPINDLE AXIS)

#124=.010(SCATTER TOL) (0.0004 in)

#125=.025(RUN OUT/CUTTING-EDGE TOL) (0.001 in)

#126=3(SAMPLE SCATTER SIZE)

## Setting-data macro variables

```
#127=5000(RAPID TRAVERSE)
#128=1(LANGUAGE 1=GB 2=D 3=FR 4=IT)
#145=.005(ZONE CHK) (0.0002 in)
#[#120+8]= #0(DISABLE LATCH)
#[#120+9]= #0(ENABLE LATCH)
N2
```

## Common variables

The following variables are loaded automatically each time a cycle is run:

```
#116 Active tool length
#129
to Used for internal calculations
#147
#148 Tolerance flag output
      (1 = Out of tolerance, 0 = In tolerance)
#149 Used for internal calculations
```

## Variables – changing the base number address

The base number defines the address of the first variable in the set of variables that are used for storing calibration data. The default address is 520, i.e. #520. This can be changed by changing the value in variable #120 in the setting-data macro (O9760).

The default base number for the Haas controller is 550 (for details, see “Appendix A – Haas controller settings”).

### Why change the base number?

The default setting uses variables #520 through #529 inclusive. This range suits all listed controllers except the Fanuc 6M and Haas.

When these variables are already used for other purposes you will need to define a different range. The following suggestions may be helpful:

- Use an additional retained common macro variable option.
- Use spare tool offsets. Use a 2000-series system variable base number, e.g. #120 = 2090 to use offsets 90 through to 99.

---

**NOTE:** If tool offset registers are used, it is not possible to switch between inch and metric units using G20/G21 because the tool offset data is converted automatically.

---

If the NC1 tool setting software is to be used without any other Renishaw inspection software present, use the default settings, unless #520 to #529 are used for other purposes.

If the NC1 tool setting software is to be used in conjunction with other Renishaw software, avoid macro #500-series clashes by changing the base number.

### Fanuc 6 systems

On later software versions, variables #500 to #511 are available.

Set the base number to 500 to use #500 to #509 inclusive.

Alternatively, use tool offsets. Set the base number to 2090 to use offsets 90 to 99 inclusive.

### Renishaw vector software packages

Variables #500 to #549 are used, so the base number must be changed.

### Renishaw Inspection Plus software

Use the standard base number (520), unless the multi-stylus calibration feature is used. In this case #500 to #549 are used, so change the base number.

## Customising the macros

In addition to the macro customising information described below, further customising and installation information is included in the ReadMe file supplied with the NC1 software.

### Editing the measure move macro (O9762)

The measure move macro contains a false trigger procedure. The default number of measurement retries following a false trigger is set to 1. This value can be changed within the range 1 to 5 if required.

#### Sample of macro O9762

```
#5=5. (* SET MAX. RETRY)
```

The back-off move distance can be adjusted for optimisation of the cycles. The tool must retract out of the beam otherwise the 92 Active Beam Cut alarm will result.

#### Sample of macro O9762

```
#6=1.2 (EDIT BOF)
```

## Orientation of the NC1 system

Throughout this guide it has been assumed that the NC1 system is installed with the laser beam parallel to the X-axis. Length measurements are made from the Z-axis and radial measurements are made from the Y-axis.

If your system has been installed in a different orientation, you must make the necessary adjustments to the axes used for length measurement and radial measurement (for details, see manually-set variables #121, #122, and #123).

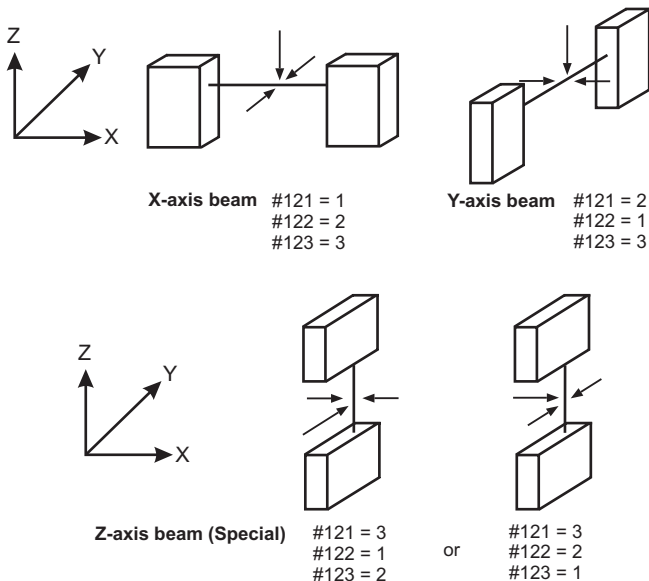

# Beam-find and measuring moves

Beam-find moves and measuring moves are all made with the tool moving **into** the laser beam, as shown in the figure. Measuring moves are made with the tool rotating.

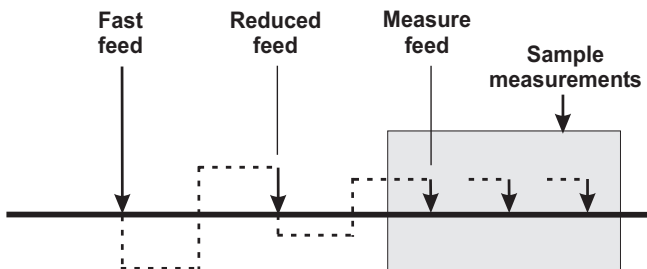



## Scatter tolerance checking

In the following example:

- The default sample size setting value (#126 = 3) is used.
- The number of retries is automatically set to twice the sample size. In this example, six (6).

Sample measurements are taken until either the maximum retries limit is reached, causing an alarm, or a sample of measurements is found to be within limits. In this latter case, the average value is found and measurement is complete.

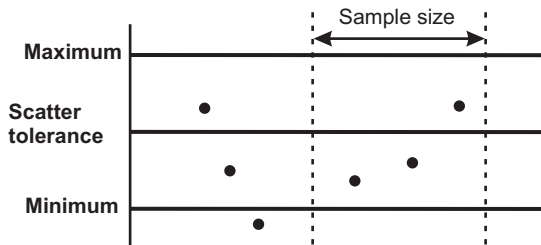

# Beam alignment (macro O9860)

---

**NOTE:** When installing and setting up the system for the first time, the beam alignment macro **must** be run **before** using macro O9861 to calibrate the system .

---

Macro O9860 is used during installation of the NC1 system to assist with the alignment of the laser beam. The beam alignment cycle is used for the following tasks:

- Checking that the beam is correctly aligned with the machine axis.
- Measuring the provisional position of the laser beam in the Z-axis.
- Measuring the provisional position of the beam in either the X or Y-axis. Measurements are taken from the positive and/or negative sides of the beam.
- Setting the measuring point along the beam axis at which the tool is measured.

The provisional values are updated later when the calibration cycle is run.

Although the beam alignment macro is used mainly during installation of the NC1 system, it can also be used for routine alignment checking.

---

**NOTE:** When using the beam alignment macro you will also need to refer to the following Renishaw publication for instructions on how to physically align the beam at the transmitter unit:

- *NC1 Installation Guide and Parts List* (Renishaw Part No. H-2000-5048)
-

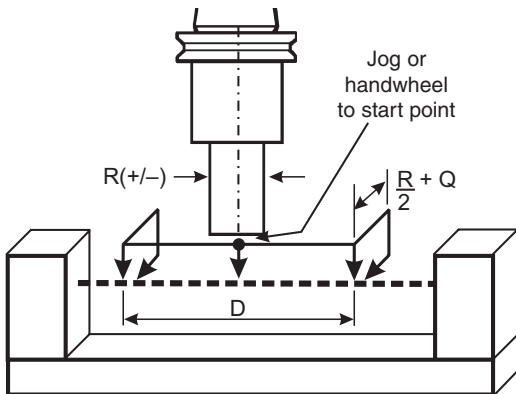

## Calibration tool required

This cycle requires a calibration tool to be loaded in the spindle of the machine. Ideally, this should be a solid, flat-bottomed, cylinder-type tool having minimal runout. The exact setting length and diameter of this tool must be known.

## Description

Load the calibration tool in the spindle of the machine. Using either the **jog or handwheel mode**, move the tool to the position that is to be used for tool setting – usually midway along the beam and **approximately 10 mm (0.394 in)** above the centre of the beam.

Refer to the figure. The cycle measures the beam then returns to the centre position and stops on an M00 program stop. After beam alignment adjustments have been made, the cycle should be restarted to identify new alignment errors.

### Setting data

Ensure the settings in macro O9760 are correct before proceeding. For details, see “Setting-data macro variables (O9760)” earlier in this guide.

### Format

#### Setting beam alignment only

G65 P9860 Tt Dd [Kk Rr Zz]

where [ ] denotes optional inputs

#### Setting beam alignment and the positions

G65 P9860 B1. Tt Dd [Kk Rr Zz]

where [ ] denotes optional inputs

**Example** G65P9860 B1. T1. D100. K122. R6. Z15.

### Macro inputs

The following inputs are used with this macro:

B1. Provisional calibration of the system.

Used for checking alignment of the beam and setting the provisional beam positional data (for details, see “Calibration-data macro variables” earlier in this guide).

---

**NOTE:** When using the B1 input, the correct length of the calibration tool **must** be entered in either the Tt tool offset register or as a Kk input value.

---

B. (Not used) – beam alignment checking only.

**CAUTION: D=d input**

When specifying the value of the D input, take care that it will not allow any part of the tool holder to make contact with the NC1 tool setting system. The projection of the calibration tool should be at least 35 mm (1.38 in) if the default Z input is used for the incremental measuring depth

- D** The span between the reference measuring points.  
For greatest accuracy, the span value must be as large as possible, compatible with the gap between the NC1 system transmitter and receiver and the size of the calibration tool.
- K** Reference length of the calibration tool.  
**Default value:** Value in the selected tool offset register
- Q** Overtravel distance and radial clearance.  
For details, see “Setting-data macro variables (O9760)” earlier in this guide.  
**Default value:** 5.0 mm (0.197 in)
- R** Diameter of tool  
This controls the radial clearance move distance. This can be either a positive (+) or negative (-) value.  
**Default value:** 30 mm (1.18 in)
- T** Tool length offset number.  
This is the offset location in which the master tool length is stored.

## Beam alignment

Z Incremental measuring depth.

This value determines the depth on the calibration tool at which calibration takes place.

**Default value:** 15 mm (0.38 in)

## Outputs

The following outputs are set or updated when this cycle is executed:

- #101 X-axis beam alignment error over the measured span.  
(This is empty if the X-axis is the beam axis.)

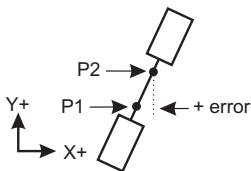

- #102 Y-axis beam alignment error over the measured span.  
(This is empty if the Y-axis is the beam axis.)

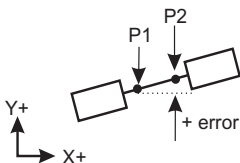

- #103 Z-axis beam alignment error over the measured span.  
(This is empty if the Z-axis is the beam axis.)

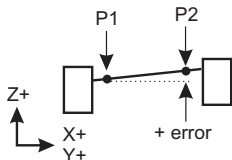

If the B1. input is used, the following outputs are also set (it is assumed the base number has been set to 520 in #120).

- #520 Provisional Z-axis position of the beam when measured from the positive side of the beam.
- #522 Provisional X or Y-axis position of the beam when measured from the positive side of the beam.
- #523 Provisional X or Y-axis position of the beam when measured from the negative side of the beam.
- #524 Provisional position along the beam axis at which the tool is measured.

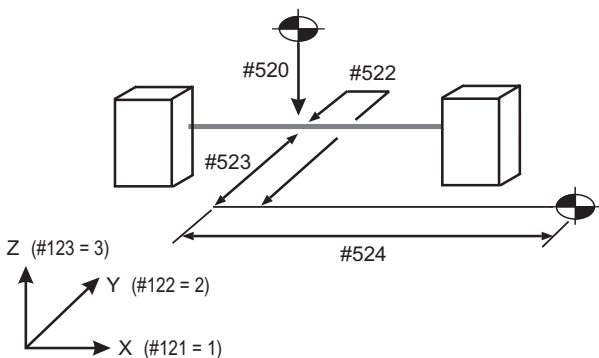

## Example

### Beam alignment and setting the provisional beam position

O????

(B1 Include approximate set cal. data)

(D Axial distance between measures)

(R Tool diameter)

(Z Search distance)

G21

M6T1

H1 (Haas only)

G0G53X302.Y-236.2

M0 (Handwheel to position)

G65P9860B1.T1.D100.

**NOTE:** Do not use the B1. input if you want to keep the current calibration data.

M0

M30



## Calibrating the NC1 (macro O9861)

Macro O9861 is used for regular calibration of the NC1 system. It should also be used after the laser beam has been aligned with the beam alignment cycle. The calibration cycle is used for the following tasks:

- Accurately calibrating the positions of the beam in the X, Y and Z-axes.
- Compensating for variations in the spindle axis and radial-measuring axis due to temperature changes in the machine tool. Temperature compensation is described in “Temperature compensation tracking (macro O9861)” later in this guide.



**CAUTION:** Before running this cycle or any other cycle (except the beam alignment macro O9860), nominal calibration data **must be** loaded.

This data can be entered automatically using the beam alignment macro O9860, with the B1 input. Alternatively, approximate data can be entered manually (for details, see “Calibration-data macro variables” earlier in this guide).

---

### Calibration tool required

This cycle requires a calibration tool to be loaded in the spindle of the machine and the tool number (T) must be active.

Ideally, this should be a solid, flat-bottomed, cylinder-type tool having minimal runout. The exact setting length and diameter of this tool must be known.

## Calibrating the NC1

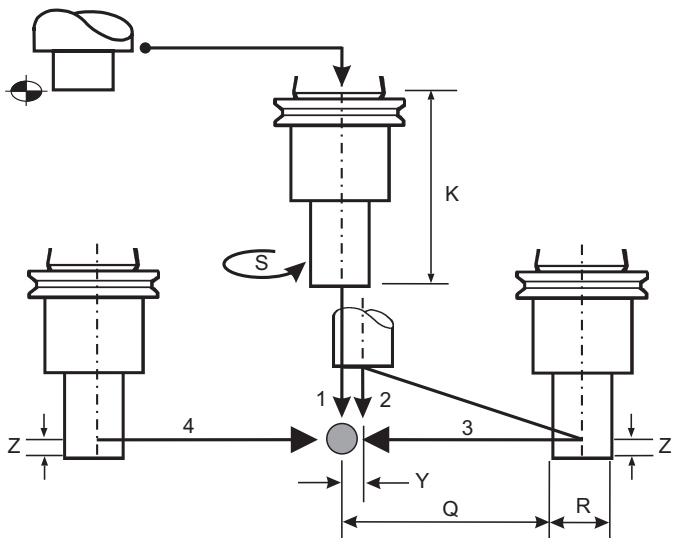

### Description

Load the calibration tool in the spindle of the machine and make the tool number (T) active before running the cycle.

The position of the beam in the Z-axis and the centre of the beam in either the X or Y-axis are calibrated while the tool is rotated. The beam width is then calibrated with the tool static. This eliminates runout errors that may be introduced by the tool.

Refer to the figure for cycle moves.

**Format** G65 P9861 B1. Rr [Cc Kk Qq Ss Tt Yy Zz]  
 where [ ] denotes optional inputs

**Example** G65P9861 B1. R12. C54. K100.210 Q5. S2500. T1.  
 Y5. Z5.

## Macro inputs

The following inputs are used with this macro:

- B1. Calibration of the system.
- C Work offset number used to track axis growth.  
 When used with the B1. input, it stores the relevant work offset values as the reference position ready for use later.  
 (See also “Temperature compensation tracking” later in this guide.)  
 C54 to C59 (G54 to G59) Fanuc/Meldas, and G54P1 to G59P1 Yasnac.  
 C53 external work offset (C52 on Haas).

### Fanuc/Meldas additional offsets

C101 to C148 (G54.1P1 to G54.1P48)

### Haas additional offsets

C110 to C129 (G110 to G129)

### Yasnac additional offsets

C54.02 to C59.05 (G54P2 to G54P5) MX3 and J50 series.

C54.02 to C59.27 (G54P2 to G54P27) I80 and J300 series.

- K** Reference length of the calibration tool.  
**Default value:** Value in the selected tool offset register.
- Q** Overtravel distance and radial clearance.  
For details, see “Setting-data macro variables (O9760)” earlier in this guide.  
**Default value:** 5.0 mm (0.197 in)
- R** Reference diameter of the calibration tool.
- S** Spindle speed at which calibration takes place. For details, see “Setting-data macro variables (O9760)” earlier in this guide.  
**Default value:** 3150 rev/min
- T** Tool length offset number.  
This is the offset location for the calibration tool. It is used for machines where the active tool number cannot be read, causing a Tool Out Of Range alarm.
- Y** Radial step-over for length calibration.  
The offset across the beam at which measurement takes place. The tool always comes down first on the beam centre-line.  
**Default value:** On-centre
- Z** Measuring height on tool.  
Determines the height of the beam on the tool at which diameter calibration takes place.  
**Default value:** 5 mm (0.197 in)

## Outputs

The following outputs are set or updated when this cycle is executed:

- #112 Temperature compensation error for length measurement.
- #113 Temperature compensation error for radial measurement.
- #520 [520 + 0] Z-axis position of the beam, when measured from the positive side of the beam.
- #522 [520 + 2] X or Y-axis position of the beam, when measured from the positive side of the beam.
- #523 [520 + 3] X or Y-axis position of the beam, when measured from the negative side of the beam.
- #524 [520 + 4] Position at which the beam is measured.
- #525 [520 + 5] Dynamic position zone.
- #526 [520 + 6] Spindle (length-measuring) axis temperature compensation work offset.
- #527 [520 + 7] Radial-measuring axis temperature compensation work offset.

## Alarms

The following alarms may be generated when this cycle is executed.

- 90 Out of Tolerance
- 91 Format Error
- 92 Active Beam Cut
- 93 Beam Not Cut

For an explanation of the meaning of alarms, see “Error messages and alarms” later in this guide.

### Example

#### Calibration

Using a calibration tool T1, which is 88.0 mm (3.46 in) long and 6.0 mm (0.236 in) diameter.

```
O????
```

```
M6T1
```

```
H1 (Haas only)
```

```
G65P9861B1.K88.R6.
```

```
M30
```

---

**IMPORTANT:** If you need to track the axis growth caused by temperature variation during the machining operation, use the C input to store the relevant work offset registers as reference values.

Typically, the external work offset G53 is used for temperature compensation tracking.

**Example:** G65P9861 B1. K88. R6. C53.

---

## Tool length setting (macro O9862)

Macro O9862 is used to measure the effective length of a cutting tool. The tool length measurement cycle is suitable for on-centre setting of tools such as drills and ball-end mills, and for off-centre setting of tools such as face mills and end mills.

### Description

Tool length is measured while the tool is rotating. The figure shows the two cycle types.

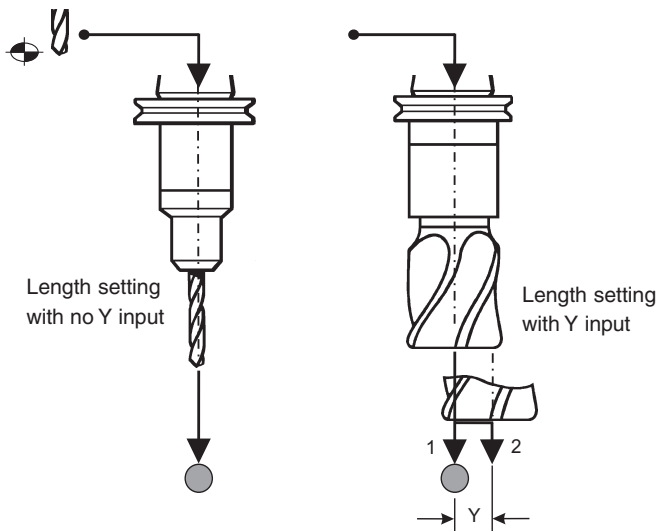

The effective tool length is written into the tool offset register. If the controller has separate wear and geometry registers, the wear register is zeroed and the length value is placed in the geometry register.

**Format** G65 P9862 [B1. Hh Jj Mm Qq Ss Tt Yy]

where [ ] denotes optional inputs

**Example** G65P9862 B1. H.5 J0.25 M1. Q5. S2500. T20. Y3.

## Macro inputs

The following inputs are used with this macro:

B1. Set the length of the tool.

B1 is the default B input.

H Tolerance value that defines when the tool length is out of tolerance.

When this input is used, the tool offset is not updated if the tool length is found to be out of tolerance.

**Default value:** No tolerance check.

J Experience value for length.

This value is the difference between the measured length of the tool and the effective length when the tool is under load during the cutting process. It is used to refine the measured length, based on previous experience of how the effective length differs from the measured length when the tool is being used.

**Default value:** Not used.



M1. Tool out of tolerance flag.

Using this flag prevents a tool Out of Tolerance alarm from being raised.

Q Overtravel distance.

For details, see “Setting-data macro variables (O9760)” earlier in this guide.

**Default value:** 5.0 mm (0.197 in)

S Spindle speed at which length measurement takes place.

For details, see “Setting-data macro variables (O9760)” earlier in this guide.

**Default value:** 3150 rev/min



### **CAUTION: T=t input**

When using the 'T' tool pre-select command after the tool change, you must use the T input on the macro call block otherwise the pre-selected tool number will be set.

---

T Tool length offset number.

This is the offset location in which the measured tool length is stored when it needs to be different from the active tool number.

**Default value:** Current tool number

Y Radial step-over for length setting.

This is the offset across the beam at which length measurement takes place. The value must be less than the

## Tool length setting

radius of the tool. The tool always comes down first on the beam centre-line.

**Default value:** On-centre

## Outputs

The following outputs are set or updated when this cycle is executed:

Set Tool Length

- #148 Out of Tolerance flag. This is set when the measured tool length is out of tolerance, provided the H input is used.  
(1 = Out of tolerance, 0 = In tolerance)

## Alarms

The following alarms may be generated when this cycle is executed.

- 90 Out of Tolerance  
91 Format Error  
96 RPM Out Of Range

For an explanation of the meaning of alarms, see “Error messages and alarms” later in this guide.

## Examples

### Tool length setting – on-centre tool

O????

M6T1

H1 (Haas only)

G65P9862B1 . Set tool offset (1) on centre

M30

A different tool offset can be set by using the T input on the call line as follows:

G65P9862B1 .S4000 .T21 . Set tool offset (21) on centre.  
Controlled rev/min.

### Tool length setting – off-centre tool

Assume the tool is 80 mm (3.15 in) diameter.

O????

M6T1

H1 (Haas only)

G65P9862B1 .Y38 .S800 Set tool offset (1) at 38 mm (1.496 in)  
radial step-over. Controlled rev/min.

M30

# Tool radius/diameter setting (macro O9862)

Macro O9862 is used for measuring the effective radius/diameter of a tool. The tool radius measure cycle allows the radius/diameter to be measured from the positive side of the beam, from the negative side of the beam, or from both sides of the beam.

## Description

The radius/diameter of a tool is measured while the tool is rotating. The figure shows the cycle moves. Radial measurement (2) can be made on either one or both sides of the beam (see setting #113 in “Setting-data macro variables (O9760)”).

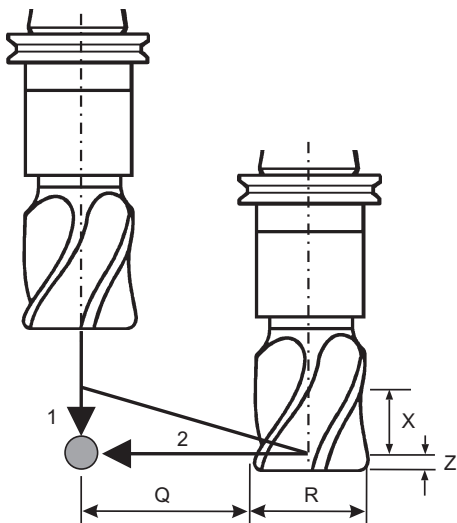

The effective radius/diameter is written into the tool offset register. If the controller has separate wear and geometry registers, the wear register is zeroed and the radius/diameter value is placed in the geometry register.

**Format** G65 P9862 B2. Dd [Hh Ii Mm Qq Rr Ss Xx Zz]

where [ ] denotes optional inputs

**Example** G65P9862 B2. D5. H.02 I.2 M1. Q5. R25. S3000.  
X2. Z6.

## Macro inputs

The following inputs are used with this macro:

---

**NOTE:** If radial measurement at an exact height on the tool is required, use the tool length and radius setting cycle (input B3.). This cycle automatically sets the length accurately before setting the radius.

---

B2. Measure the radius of the tool.

D Diameter offset number.

This is the offset location in which the measured tool radius/diameter is stored.

**Default value:** When offset types have separate registers for length and radius, the active tool offset number is used.

H Tolerance value that defines when the tool diameter is out of tolerance.

When this input is used, the tool offset is not updated if the

tool diameter is found to be out of tolerance.

**Default value:** No tolerance check.

- I Experience value for diameter or radius.

This value is the difference between the measured diameter/radius of the tool and the actual diameter/radius when the tool is under load during the cutting process. It is used to define the measured diameter/radius, based on previous experience of how the effective diameter/radius differs from the measured diameter/radius when the tool is under load.

**Default value:** Not used.

---

**NOTE:** For cutter centre-line programming applications, entering the nominal size as an experience value will result in the error being stored instead of the full radius/diameter of the cutter.

---

- M1. Tool out of tolerance flag.

Using this flag prevents a tool Out of Tolerance alarm from being raised.

- Q Overtravel distance and radial clearance.

For details, see “Setting-data macro variables (O9760)” earlier in this guide.

**Default value:** 5.0 mm (0.197 in)

- R Diameter of tool.

This is the nominal diameter of the tool.

**Default value:** Maximum diameter of tool in #112.

S Spindle speed at which diameter measurement takes place. For details, see “Setting-data macro variables (O9760)” earlier in this guide.

**Default value:** 3150 rev/min

X Spindle axis search distance.

This defines a search distance above the Z input measuring height, which can be used to find a radial high spot on the cutter. It is suitable for single-point boring bars and cutters with irregular radial profiles. Cycle time is increased using this input.

**Default value:** Zero (0)

Z Measuring height of tool.

This is the Z-axis position from the end face of the tool at which measurement takes place.

**Default value:** 5.0 mm (0.197 in)

## Outputs

The following outputs are set or updated when this cycle is executed:

Set Tool Radius/Diameter

#148 Out of Tolerance flag. This is set when the measured tool length is out of tolerance, provided the H input is used.  
(1 = Out of tolerance, 0 = In tolerance)

### Alarms

The following alarms may be generated when this cycle is executed.

- 90 Out of Tolerance
- 91 Format Error
- 95 D Input Missing
- 96 RPM Out Of Range

For an explanation of the meaning of alarms, see “Error messages and alarms” later in this guide.

### Examples

#### Tool radius setting 1

Assume the tool is a 10 mm (0.394 in) diameter slot drill.

```
O????
```

```
M6T1
```

```
H1 (Haas only)
```

```
G65P9862B2.D21. Set tool radius offset (21)
```

```
M30
```



### Tool radius setting 2

Assume the tool is an 80 mm (3.15 in) diameter cutter.

O????

M6T1

H1 (Haas only)

G65P9862B2.D21.S800.R80.    Set tool radius offset (21).  
Controlled radial clearance  
and rev/min.

M30

# Tool length and radius setting (macro O9862)

Macro O9862 is used for measuring the effective length and radius/diameter of a tool. The tool length and radius measure cycle is particularly suitable for tools such as face mills, end mills, slot cutters, disc mill cutters, dovetail cutters and boring tools.

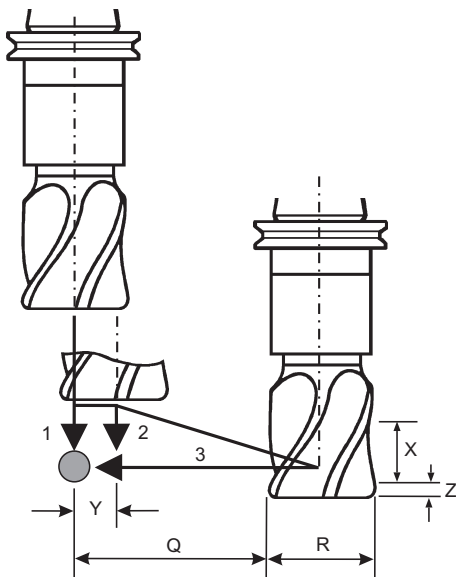

### Description

This single cycle combines the tool length measuring cycle (see “Tool length setting” earlier in this guide) and tool radius/diameter measuring cycle (see “Tool radius/diameter setting”).

The figure shows the combined cycle moves. Radial measurement (3) can be made on either one or both sides of the beam (see setting #113 in “Setting-data macro variables (O9760)”).

Length and radius values are written into the tool offset register. If the controller has separate wear and geometry registers, the wear registers are zeroed and the values are placed in the geometry registers.

**Format** G65 P9862 B3. Dd [Hh Ii Jj Mm Qq Rr Ss Tt Yy Xx Zz]  
where [ ] denotes optional inputs

**Example** G65P9862 B3. D5. H.02 I.02 J.025 M1. Q5. R25. S2500  
T20. Y3. X2. Z6.

---

**NOTE:** When inputs I, J and K are used, they must be specified in alphabetical order.

---

### Macro inputs

The following inputs are used with this macro:

- B3. Measure the length and radius of the tool.

## Tool length and radius setting

- D Diameter offset number.

This is the offset location in which the measured tool diameter is stored.

**Default value:** When offset types have separate registers for length and radius, the active tool offset number is used.

- H Tolerance value that defines when the tool is out of tolerance.

When this input is used, the tool offset is not updated if the tool is found to be out of tolerance.

**Default value:** No tolerance check.

- I Experience value for diameter or radius.

This value is the difference between the measured diameter/radius of the tool and the actual diameter/radius when the tool is under load during the cutting process. It is used to define the measured diameter/radius, based on previous experience of how the effective diameter/radius differs from the measured diameter/radius when the tool is under load.

**Default value:** Not used.

---

**NOTE:** For cutter centre-line programming applications, entering the nominal size as an experience value will result in the error being stored instead of the full radius/diameter of the cutter.

---

- J Experience value for length.

This value is the difference between the measured length of the tool and the actual length when the tool is under load

during the cutting process. It is used to refine the measured length, based on previous experience of how the effective length differs from the measured length when the tool is under load.

**Default value:** Not used.

M1. Tool out of tolerance flag.

Using this flag prevents a tool Out of Tolerance alarm from being raised.

Q Overtravel distance and radial clearance.

For details, see “Setting-data macro variables (O9760)” earlier in this guide.

**Default value:** 5.0 mm (0.197 in)

R Diameter of tool.

This is the nominal diameter of the tool.

**Default value:** Maximum diameter of tool in #112.

S Spindle speed at which length and diameter measurement takes place. For details, see “Setting-data macro variables (O9760)” earlier in this guide.

**Default value:** 3150 rev/min



### CAUTION: T=t input

When using the 'T' tool pre-select command after the tool change, you must use the T input on the macro call block otherwise the pre-selected tool number will be set.

T Length offset number.

This is the offset location in which the measured tool length is stored.

**Default value:** Current tool number

X Spindle axis search distance.

This defines a search distance above the Z input measuring height, which can be used to find a radial high spot on the cutter. It is suitable for single-point boring bars and cutters with irregular radial profiles. Cycle time is increased using this input.

**Default value:** Zero (0)

Y Radial step-over for length setting.

This is the offset across the beam at which length measurement takes place. The value must be less than the radius of the tool. The tool always comes down first on the beam centre-line.

**Default value:** On-centre

Z Measuring height of tool.

This is the Z-axis position from the end face of the tool at which measurement takes place.

**Default value:** 5.0 mm (0.197 in)

### Outputs

The following outputs are set or updated when this cycle is executed:

Set tool length

Set tool radius/diameter

#148 Out of Tolerance flag. This is set when the measured tool length is out of tolerance, provided the H input is used.  
(1 = Out of tolerance, 0 = In tolerance)

### Alarms

The following alarms may be generated when this cycle is executed.

- 90 Out of Tolerance
- 91 Format Error
- 94 Same T and D Offset
- 95 D Input Missing
- 96 RPM Out Of Range

For an explanation of the meaning of alarms, see “Error messages and alarms” later in this guide.

### Examples

#### Tool length/radius setting 1

Assume the tool is a 10 mm (0.394 in) diameter slot drill.

O????

M6T1

H1 (Haas only)

G65P9862B3.D21. Set tool length offset (1) and radius  
offset (21)

M30

#### Tool length/radius setting 2

Assume the tool is an 80 mm (3.15 in) diameter cutter.

O????

M6T1

H1 (Haas only)

G65P9862B3.D21.Y38.T10.S800. Set tool length offset (10)  
at 38 mm (1.496 in)  
radial step-over and set  
radius offset (21).  
Controlled rev/min.

M30



## Cutting edge checking (macro O9862)

**NOTE:** This cycle can be used only if the latch mode feature of the NC1 system is installed and operational.

Macro O9862 is used for checking the cutting edges of a tool. The diameter cutting edge check cycle checks for either missing or damaged teeth or for excessive runout of the cutter.

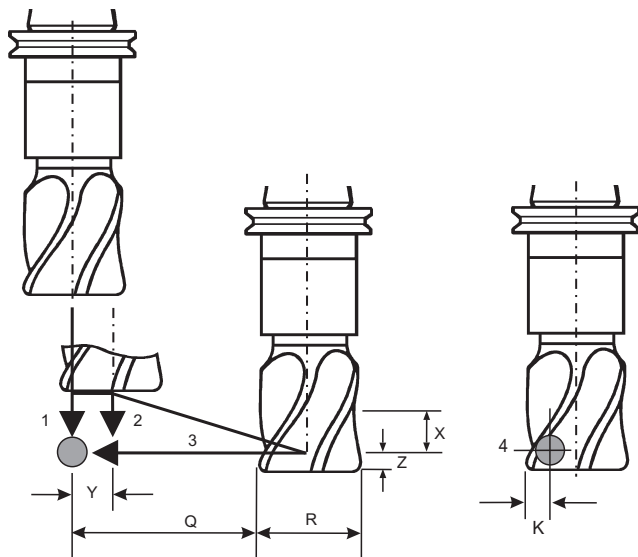

### Description

Before a tool is checked for missing teeth or excessive runout, it is first set for radius/diameter. The diameter cutting edge check cycle then moves the rotating tool into the beam until the teeth interfere with the beam by the cutting edge runout tolerance value. This value is defined by the K input.

The spindle speed is calculated from the minimum pulse signal delay (#115) of the NC1 system and the number of teeth on the cutting tool. This ensures that when each tooth enters the beam, a permanent beam cut signal is held unless a tooth is either missing or is out of tolerance. The beam cut signal is monitored for a minimum of two revolutions.

**Format** G65 P9862 B2. or B3. Cc [Kk Mm Qq Rr Ss Zz Xx Ff]  
where [ ] denotes optional inputs

**Example** G65 P9862 B2. or B3. C6. K0.02 M1. Q5. R25.  
S2500. Z6. X5.0 F.1

### Macro inputs

The following inputs are used with this macro:

- B2. For details of these cycles, see either “Tool radius/diameter setting” or “Tool length and radius setting” earlier in this guide.
- B3. Cutting edge check without tool offset updating.
- B4. Cutting edge check without tool offset updating.
- C The number of teeth on the tool. This automatically selects the cutting edge check.

**Default value:** No default.

- D Diameter offset number.  
This is the offset location in which the measured tool radius/diameter is stored.  
**Default value:** When offset types have separate registers for length and radius, the active tool offset number is used.
- F Feedrate-per-rev. for cylinder profile checking when using the X input.  
**Default value:** 0.1 mm (0.0394 in)
- K The tolerance value that defines when the tool cutting edge runout is excessive.  
**Default value:** 0.025 mm (0.0098 in)
- M1. Tool out of tolerance flag.  
Using this flag prevents a tool Out of Tolerance alarm from being raised.
- Q Overtravel distance and radial clearance.  
For details, see “Setting-data macro variables (O9760)” earlier in this guide.  
**Default value:** 5.0 mm (0.197 in)
- R Nominal diameter of the tool.  
**Default value:** Maximum diameter of tool in #112.
- S Spindle speed at which radius/diameter measurement takes place. For details, see “Setting-data macro variables (O9760)” earlier in this guide.  
The spindle speed for cutting edge checking is set

## Cutting edge checking

automatically and is based on the minimum pulse signal delay of the control and the number of teeth on the tool.

**Default value:** 3150 rev/min.

- X Cylinder profile checking distance, i.e. the spindle axis movement, while edge checking. The value is incremental from the Z input radial measuring position. It is used in conjunction with the F input feed rate.

**Default value:** Zero (0)

- Z Measuring height of tool.

This is the Z-axis position from the end face of the tool at which measurement takes place.

**Default value:** 5.0 mm (0.197 in)

## Outputs

The following outputs are set or updated when this cycle is executed:

- #148 Out of Tolerance / Missing edge flag.

This is set when either the tool cutting edge runout is out of tolerance, provided the K input is used, or an edge is missing from the tool.

(2 = Out of tolerance / edge missing)

0 = In tolerance / no edges missing)

## Alarms

The following alarms may be generated when this cycle is executed.

- 90 Out of Tolerance

- 91 Format Error

- 92 Active Beam Cut
- 94 Same T and D Offset
- 95 D Input Missing
- 96 RPM Out Of Range
- 98 Run-out/Edge Missing

For an explanation of the meaning of alarms, see “Error messages and alarms” later in this guide.

## Examples

### Cutting edge checking

Assume a 2-flute slot drill and check for a broken edge 0.5 mm from the end face of the cutter.

O????

M6T1

H1 (Haas only)

G65P9862B2.C2.D21.Z0.5

### Cylinder cutting edge checking

O????

M6T1

H1 (Haas only)

G65P9862B3.C2.Z0.5X5.0

### Broken tool detection – plunge checking (macro O9863)

Macro O9863 is used to check for breakage of cutting tools. The broken tool cycle uses a plunge check, where the tool is moved into and out of the laser beam in the axis used for length setting. The cycle can also check for a 'long tool' condition, where the tool has possibly pulled out during machining.

Typically, a tool needs to be checked after a machining operation to verify that it is not broken before the next tool is selected.

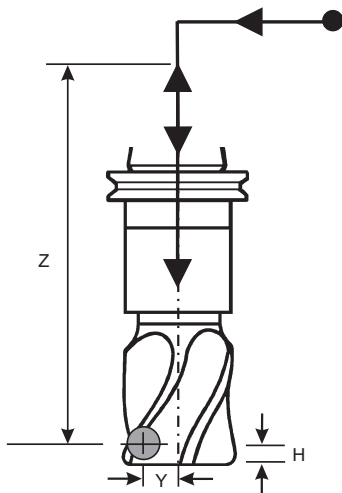

### Description

Detection of a broken tool occurs while the tool is rotated in the beam. Moves into and out of the beam are at the rapid feedrate.

The tool first moves over the beam, in the X and Y axes, to the measuring position and then moves, in Z, to the tool checking position.

When a positive H input is used, the tool is checked at the broken tool position only. When a negative H input is used, the tool is checked at both the long tool and broken tool positions.

At the end of the cycle, the tool moves out of the beam to the safe position in the spindle axis only.



**CAUTION:** Before this cycle is run, the current tool offset must be active.

**Format** G65 P9863 [Hh Mm Ss Yy Zz]

where [ ] denotes optional inputs

**Example** G65P9863 H5. M1. S2800 Y3. Z6.

### Macro inputs

The following inputs are used with this macro:

- H Tolerance value that defines when the tool is defined as broken. A negative value (H-) checks the tool for both broken and long tool conditions.

**Default value:** 0.5 mm (0.0197 in).

## Broken tool detection (plunge checking)

M1. Tool broken flag.

Using this flag prevents a Broken Tool / Out of Tolerance alarm from being raised.

S Spindle speed at which checking for a broken tool takes place. For details, see “Setting-data macro variables (O9760)” earlier in this guide.

**Default value:** 3150 rev/min.

Y Radial step-over distance.

The offset across the beam at which measurement of the tool length takes place.

**Default value:** On-centre

Z Safety plane.

The distance (in the spindle axis) to which the tool is retracted.

**Default value:** No retract

## Outputs

The following output is always set when this cycle is executed:

#148 Broken Tool flag.

(2 = long tool, 1 = broken tool, 0 = good tool)



### Alarms

The following alarms may be generated when this cycle is executed.

- 91     Format Error
- 96     RPM Out Of Range
- 99     Broken Tool

For an explanation of the meaning of alarms, see “Error messages and alarms” later in this guide.

### Example

#### Broken tool detection – plunge check

O?????

M6T1

G0G43H1Z200 .

(complete the machining sequence with tool T1)

G0Z200 .

Move to a safe position where the broken tool cycle can be called.

X200 .Y300 .

G65P9863Z100 .

Make a broken tool check. Either a broken tool alarm is raised and the program stops, or the program continues.

M6T2

Select the next tool and continue.

(continue machining)

## Broken tool detection (plunge checking)

If the broken tool flag method is used, the call cycle is modified as follows:

G65P9863Z100.M1.      Make a broken tool check without raising an alarm.

The #148 flag is set.

IF[#148EQ1]GOTO100      Go to N100

(continue program)

Block N100 will contain corrective actions. For example, selecting a sister tool for use, or selecting a new pallet/component.

## Broken tool detection – radial checking (macro O9864)

Macro O9864 is used to check for breakage of cutting tools. The broken tool cycle uses a radial check, where the tool is moved through the laser beam in the direction used for radius/diameter setting.

Typically, a tool needs to be checked after a machining operation to verify that it is not broken before the next tool is selected.

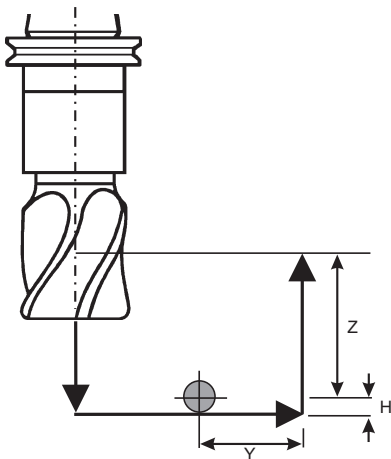

### Description

Detection of a broken tool occurs while the tool is rotated in the beam. Moves through the beam are at the rapid feedrate.

The cycle rapids the tool to the measuring height at a depth defined

## Broken tool detection (radial checking)

by the broken tool tolerance value (H input) The tool then moves in rapid through the beam and is monitored for a broken tool condition, i.e. the beam is not cut. The radial distance moved by the tool from the beam centre-line is defined by the Y input.

At the end of the cycle, the tool moves out of the beam to the safe position in the spindle axis only.



### CAUTION

1. The latch mode feature of the NC1 system must be installed and operational if the Y input is to be used when passing the tool through the beam.
2. Before this cycle is called, the tool must be moved to a safe, clear position in the Z, X, and Y axes. Ensure that the position along the beam axis to which the tool is moved is safe for radial checking.
3. Before this cycle is run, the current tool offset must be active.

**Format** G65 P9864 [Hh Mm Ss Yy Zz]

where [ ] denotes optional inputs

**Example** G65P9864 H5. M1. S2800 Y3. Z6.

## Macro inputs

The following inputs may be required for this macro:

H Tolerance value that defines when the tool is defined as broken.

**Default value:** 0.5 mm (0.0197 in).

M1. Tool broken flag.

Using this flag prevents a Broken Tool alarm from being raised.

S Spindle speed at which checking for a broken tool takes place. For details, see “Setting-data macro variables (O9760)” earlier in this guide.

**Default value:** 3150 rev/min.

Y Monitoring distance past the beam centre-line.

Use a Y- (negative) value for a negative axis move.

**Default value:** On-centre

Z Safety plane.

The distance (in the Z-axis) to which the tool is retracted.

**Default value:** No retract

## Outputs

The following output is always set when this cycle is executed:

#148 Broken Tool flag.

(1 = broken tool, 0 = good tool)

## Alarms

The following alarm may be generated when this cycle is executed.

99 Broken Tool

For an explanation of the meaning of alarms, see “Error messages and alarms” later in this guide.

### Example

#### Broken tool detection – radial check

O????

M6T1

G0G43H1Z200.

(complete the machining sequence with tool T1)

G0Z200.

Move to a safe position in the Z-axis where the broken tool cycle can be called.

X200.Y300.

Move to a safe position in the X and Y axes where the broken tool cycle can be called.

G65P9864Y50.Z100.

Make a broken tool check. Either a broken tool alarm is raised and the program stops, or the program continues.

M6T2

Select the next tool and continue.

(continue machining)

If the broken tool flag method is used, the call cycle is modified as shown:

G65P9864Y50.Z100.M1.

Make a broken tool check without raising an alarm.

The #148 flag is set.

IF[#148EQ1]GOTO100

Go to N100

(continue program)

Block N100 will contain corrective actions. For example, selecting a sister tool for use, or select a new pallet/component.

# Cutter radius and linear profile checking (macro O9865)

---

**NOTE:** This cycle can be used only if the latch mode feature of the NC1 system is installed and operational.

---

This cycle is used to check the profile of ballnose cutters, cutters with corner radii, and cutters with linear profiles. The profile is checked to find out if it is within a specified form tolerance.

## Application

The tool is retracted to the home position for safety before each profile check unless a secondary profile check is to be performed on the same tool (see use of inputs B4, B5, and B6). The tool is positioned over the laser beam and is moved first to the longest tool position, then to the profile start position with the spindle rotating. The defined cutter profile is traced at the checking feedrate. Finally, the tool is retracted out of the beam. An error flag is always set and an alarm is optionally generated if the cutter is out of tolerance.

If both + and – tolerance checking is specified with the B3 and B6 inputs, the cutter is repositioned after the negative (–) tolerance check and a reverse profile check is made along the profile. Finally, the tool is retracted.





## Linear profile checking

G65P9865 Xx [Bb Cc Ff Hh Kk Mm Qq Ss Tt Yy Zz]

**Example** G65P9865 B1. C4. F.3 H.5 K.1 M1. Q90. S4000. T20.  
X5. Y5. Z50.

## Macro inputs

- B1. Check the cutter profile along the negative (-) tolerance profile limit (see the figures on page 70).
- B2. Check the cutter profile along the positive (+) tolerance profile limit (see the figures on page 70).
- B3. Combine both B1 and B2 profile checking in one operation. This is the default if the B input is not used.
- B4. These are the same as the B1, B2, and B3 inputs
- B5. respectively, except that the tool does not retract first.
- B6. These cycles are suitable for performing secondary profile checks on the same tool.

---

**TIP:** To prevent retracting at the end of the cycle, use a Z0 input.

---

- C When this input is used, enter the number of cutting edges on the tool. The spindle speed is then automatically adjusted to enable errors on each cutting edge to be checked.  
The cycle time using this method is significantly increased,

## Cutter radius and linear profile checking

unless the default 0.1 mm/rev (0.004 in/rev) is increased using the F input.

**Default value:** The spindle speed is set by either the S input, or by the default value defined in the setting macro O9760 when no S input is used.

- C1. The spindle speed is automatically adjusted for a cutter with a single cutting-edge to ensure it is properly checked.

This is also suitable for multiple-tooth cutters, when only the maximum/minimum cutting-edge profile needs to be checked. The cycle time will be faster than checking each individual cutting edge.

- F Feedrate specified as feed/rev for profile checking.

**Default value:** 0.1 mm/rev (0.004 in/rev)

- K The tolerance value that defines when the cutter profile is out of limits.

**Default value:** 0.025 mm (0.001 in)

- M1. Used to prevent an alarm being raised when the profile is out of limits.

- S The spindle speed for the cutter.

This value is used for profile checking when no C input is used; otherwise, the spindle speed is adjusted automatically for profile checking.

**Default value:** 3150 rev/min.

- T Length offset number.  
This is the offset location in which the measured tool length is stored.  
**Default value:** Current tool number
- Z Retract distance after profile checking.  
The tool reference point is retracted to this position.  
**Default value:** Retract to the home position

### Additional macro inputs for radius profile checking only

- H The height from the tool length offset position to the bottom of the radius profile, i.e. the J0 position (see the figures on page 70).  
**Range:**  $\geq 0$
- J Start position adjustment relative to the cutter radius centre for profile checking (see the figures on page 70).  
**Range:** radial  $\geq 0 < R$  input
- Q Included angle of the cutter radius.  
**Range:**  $\geq 0^\circ \leq 90^\circ$
- R The cutter radius value.
- X Linear distance moved tangentially past the cutter radius profile (see the figures on page 70).  
**Range:**  $\geq 0$
- Y Radial distance to the cutter radius centre.  
**Range:**  $\geq 0$

### Additional macro inputs for linear profile checking only

- H The height to the first profile checking position (see the figures on page 70).  
This is the height above the tool length offset position.  
**Range:**  $\geq 0$
- Q Angle of the linear profile (see the figures on page 70).  
**Range:**  $\geq 0^\circ \leq 90^\circ$
- X Distance along the surface for profile checking (see the figures on page 70).  
**Range:**  $\geq 0$
- Y Radial position to the first profile checking position.  
**Range:**  $\geq 0$

## Outputs

---

**NOTE:** When the B3 or B6 input is used and the tool is found to be out of tolerance during the negative (-) tolerance profile check, the cycle is automatically aborted and does not complete the positive (+) tolerance profile check.

---

- #148=0 The profile is in tolerance
- #148=1 The profile is out of tolerance during negative (-) tolerance profile checking
- #148=2 The profile is out of tolerance during positive (+) tolerance profile checking

## Alarms

The following alarms may be generated when this cycle is executed.

- 91     Format Error
- 96     RPM Out Of Range
- 97     Tool Out of Range
- 98     Run-out/Edge Missing

For an explanation of the meaning of alarms, see “Error messages and alarms” later in this guide.

## Examples

### Profile checking a Ø20 mm (0.787 in) ballnose cutter

Check the profile is within  $\pm 0.05$  mm (0.002 in)

The profile checking starts at 1 mm (0.040 in) radial from the cutter centre and then moves around the 90° radius, and then a further 15 mm (0.591 in) up the diameter of the tool

```
O????
```

```
M6T1
```

```
H1 (Haas only)
```

```
G65P9865R10.X15.J1.K.05
```

```
M30
```

## Cutter radius and linear profile checking

### Profile checking a Ø20 mm (0.787 in) tapered cutter with 10° side taper

Check the profile is within  $\pm 0.05$  mm (0.002 in)

The profile check starts at 1 mm (0.040 in) high and 10.176 mm (0.401 in) radial, and then moves along the taper for 30 mm (1.181 in).

O????

M6T1

H1 (Haas only)

G65P9865H1.K.05Q80.X30.Y10.176

M30

## Temperature compensation tracking (macro O9861)

Macro O9861 can be used to calibrate the NC1 system for variations in the spindle axis and/or the radial-measuring axis caused by temperature changes in the machine tool.

Run this cycle on a regular basis during machining operations to compensate for growth in the spindle axis and/or radial-measuring axis.

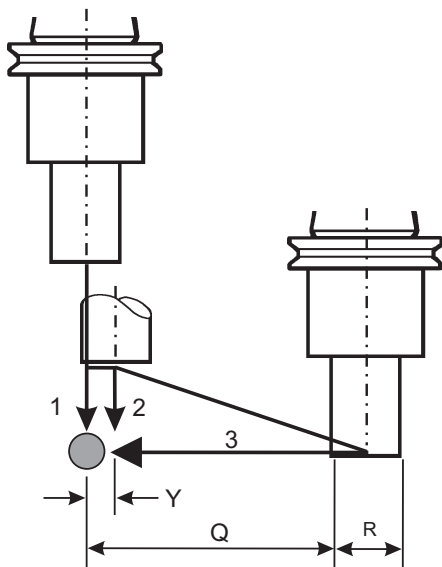

### Description

The calibration tool must be loaded in the spindle of the machine.

Refer to the figure showing cycle moves.

The macro is used as described previously in “Calibrating the NC1 (macro O9861)”, but instead of resetting the calibration data, the beam positions are compared with the original calibration values. The deviation for each axis is then used to adjust the relevant work offset.

---

**NOTE:** It is important to use the same calibration tool and input values that were previously used for calibration, except that input B4., B5. or B6. is now used.

After the original reference values have been stored, independent adjustments to the work offset values are ignored and overwritten by the temperature tracking cycle.

---

### Format

#### Full temperature compensation

G65 P9861 B6. Cc Rr [Kk Qq Ss Tt Yy]  
where [ ] denotes optional inputs

**Example** G65P9861 B6. C53. R6. K122. Q5. S2500. T1. Y5.

#### Spindle axis temperature compensation

G65 P9861 B4. Cc [Kk Qq Ss Tt Yy]

**Example** G65P9861 B4. C53. K122. Q5. S2500. T1. Y5.



## Radial measuring axis temperature compensation

G65 P9861 B5. Cc Rr [Qq Ss]

**Example** G65P9861 B5. C53. R6. Q5. S2500.

## Macro inputs

The following inputs are used with this macro:

- B4. Temperature compensation tracking in the spindle axis. This performs a beam find and length measurement in the spindle axis only.
- B5. Temperature compensation tracking in the radial-measuring axis. This performs a beam find and radial measurement only.
- B6. Temperature compensation tracking in both the spindle axis and radial-measuring axis. This performs both operations described for inputs B4. and B5.
- C Work offset number used to track axis growth due to temperature effects. This must be the same as that used with the B1. input for calibration  
Refer to the C input description in “Calibrating the NC1 (macro O9861)” for controller/offset options.
- K Reference length of the calibration tool.  
**Default value:** Value in the selected tool offset register
- H Tolerance for the maximum variation of temperature changes.  
**Default value:** No tolerance check.

## Temperature compensation tracking

- Q Overtravel distance and radial clearance.  
For details, see “Setting-data macro variables (O9760)” earlier in this guide.  
**Default value:** 5.0 mm (0.197 in)
- R Reference diameter of the calibration tool.
- S Spindle speed at which calibration takes place. For details, see “Setting-data macro variables (O9760)” earlier in this guide.  
**Default value:** 3150 rev/min
- T Tool length offset number.  
This is the offset location for the calibration tool. It is used for machines where the active tool number cannot be read, causing a Tool Out Of Range alarm.
- Y Radial step-over for length calibration.  
This is the offset across the beam at which measurement takes place. The tool always comes down first on the beam centre-line.  
**Default value:** On-centre

## Outputs

The following outputs are set or updated when this cycle is executed:

- #112 Temperature compensation error for length measurement.
- #113 Temperature compensation error for radial measurement.
- G?? The work offset axis values are corrected.

## Alarms

The following alarms may be generated when this cycle is executed.

- 90 Out of Tolerance
- 91 Format Error
- 92 Active Beam Cut
- 93 Beam Not Cut

For an explanation of the meaning of alarms, see “Error messages and alarms” later in this guide.

## Example

To track the growth in the spindle axis and radial-measuring axis. The external work offset is used to store the compensations.

```
O????  
M6T1  
H1 (Haas only)  
G65P9861B6 . C53 . K88 . R6 .  
M30
```

Alternatively, if individual axis tracking is required, use either the B4. or B5. input.

# Error messages and alarms

Error messages are displayed by the error macro program O9769.

When an error state is detected, an error message is displayed on the screen of the controller. Error messages, their meaning, and typical actions needed to clear them are described below.

Fanuc 0M controls display alarm numbers by adding a base number (500 + n) to the numbers shown here.

**Message** 80 MISSING DATA IN O9760  
580 MISSING DATA IN O9760

**Meaning** This alarm is raised if the cycle is run without entering suitable setting data in macro O9760. This usually happens after software installation when the beam alignment macro O9860 is run for the first time.

**Action** The alarm is raised by monitoring #121 in the setting-data macro for a valid value. Check all data at this point to ensure that the default values supplied with the software are suitable for your machine and application.

This is a reset condition.

**Message** 81 SCATTER TOLERANCE  
581 SCATTER TOLERANCE

**Meaning** At least one measurement in the sample is outside the scatter tolerance limit. The alarm is raised when the retries limit is reached (for details, see “Scatter tolerance checking” earlier in this guide).

**Action** Review the sample size and scatter tolerance requirements.  
Check the reason for poor measurement performance and/or check the sample size and scatter tolerance values. Poor measurement performance can be caused by coolant and swarf on the tool.  
Also check for mechanical movement of the tool/tip insert or NC1 system.  
This is a reset condition.

**Message** 87 FALSE TRIGGER  
587 FALSE TRIGGER

**Meaning** The beam has been cut several times during a measurement move. This may be caused by coolant triggering the beam.

**Action** Identify and correct the cause of the false triggers. The default number of retries allowed is set to 1. If necessary, change this number in macro O9762 (for details, see “Editing the measure move macro (O9762)”).  
This is a reset condition.

**Message** 90 OUT OF TOLERANCE  
590 OUT OF TOLERANCE

**Meaning 1** Macro O9862: The measured length or diameter of the tool is out of tolerance (either a positive or negative limit is exceeded). This may be caused by a broken tool or the tool being pulled out of its holder.

**Action 1** Reset and replace the tool, or adjust the tool then reset it.

## Error messages and alarms

**Meaning 2** Macro O9861: The temperature compensation drift values have exceeded the allowable tolerance.

**Action 2** Investigate the cause of excessive movement. The work offset registers used for temperature compensation may have been wrongly adjusted since storing reference values.

This is a reset condition.

**Message** 91 FORMAT ERROR  
591 FORMAT ERROR

**Meaning** A macro input is either missing or the value entered is incorrect.

**Action** Correct the macro input line then run again.

This is a reset condition.

**Message** 91 COMMAND POS ERROR (**Yasnac only**)

**Meaning** An excessive back-off move from the measured surface is detected.

**Action** Switch the machine OFF and ON again, then retry. If the problem persists, contact Renishaw for advice.

This is a reset condition.

**Message** 92 ACTIVE BEAM CUT  
592 ACTIVE BEAM CUT

**Meaning** The receiver is registering a cut beam signal at the start of a measuring move. This may be due to the tool, swarf or coolant interfering with the beam.

**Action** Correct the error then try again.

This is a reset condition.

- Message** 93 BEAM NOT CUT  
593 BEAM NOT CUT
- Meaning** The receiver has not registered a beam cut condition during the measuring move, possibly because the tool is missing or the measuring distance is insufficient to reach the beam. This may be due to bad macro input data or failure to properly calibrate the probe system.
- Action** Correct the error then try again.  
This is a reset condition.
- Message** 94 SAME T AND D OFFSET  
594 SAME T AND D OFFSET
- Meaning** The same tool offset number has been used for the length and diameter/radius.
- Action** Correct the macro input line then run the macro again.  
This is a reset condition.
- Message** 95 D INPUT MISSING  
595 D INPUT MISSING
- Meaning** The diameter/radius offset number has not been included in the macro statement.
- Action** Edit the program.
- Message** 96 RPM OUT OF RANGE <800  
596 RPM OUT OF RANGE <800
- Meaning** The value entered in the S input is less than the minimum value of 800 rev/min.
- Action** Correct the macro input line then run the macro again.  
This is a reset condition.

## Error messages and alarms

- Message** 97 TOOL OUT OF RANGE  
597 TOOL OUT OF RANGE
- Meaning** Either the size of the cutting tool exceeds the size that is set in variables #110 to #112 inclusive, or the tool offset number / tool number is wrong.
- Action** Edit the program. Check the cutter size.
- Message** 98 RUN-OUT/EDGE MISSING  
598 RUN-OUT/EDGE MISSING
- Meaning** A cutting edge is missing or damaged, or the tool is eccentric.
- Action** Replace or adjust the defective tool, or modify the tolerance value.
- Message** 99 BROKEN TOOL  
599 BROKEN TOOL
- Meaning** The tool is out of tolerance.
- Action** Replace the defective tool and establish the correct tool offset value.



## Appendix A Haas controller settings

Variable #120 is used to define the base number of the calibration data variables. The base number can be changed to avoid conflicts with other software applications.

For Haas controllers, the default base number is 550. If this number is not suitable and needs to be changed, do this as described in “Variables – changing the base number address” earlier in this guide.

Type 'C' offsets	Length	#108=3 fixed
	Length – wear	
	Radius	
	Radius – wear	

### Automatically-set calibration variables

The following variables are set automatically during the calibration cycles.

#550 (550 + 0)	Z-axis position of the beam, when measured from the positive side of the beam.
#551 (550 + 1)	(Reserved)
#552 (550 + 2)	X or Y-axis position of the beam, when measured from the negative side of the beam.
#553 (550 + 3)	X or Y-axis position of the beam, when measured from the positive side of the beam.
#554 (550 + 4)	Position along the beam at which measurements are made.

## Appendix A – Haas controller settings

#555 (550 + 5)	Dynamic position zone.
#556 (550 + 6)	Spindle (length-measuring) axis temperature compensation work offset.
#557 (550 + 7)	Radial-measuring axis temperature compensation work offset.

# Appendix B Yasnac controller settings

The Yasnac range of controllers – MX3, J50, I80 and J300 – use a different configuration of tool offset options to those used by Fanuc. There are no separate wear and geometry registers.

Set the tool offset type in the setting-data macro (O9760) as follows:

### MX3 and J50 controllers

Basic 99 offsets	H and D common	#108=1
299 Pair option	H and D common	#108=1
Basic 99 offsets	H and D separate	#108=2
299 Pair option	H and D separate	#108=3

### I80 and J300 controllers

Basic 99 offsets	H and D common	#108=1
299 Pair option	H and D common	#108=1
999 Pair option	H and D common	#108=1
1199 Pair option	H and D common	#108=1
Basic 99 offsets	H and D separate	#108=2
299 Pair option	H and D separate	#108=3
999 Pair option	H and D separate	#108=4
1199 Pair option	H and D separate	#108=5

# Appendix C Meldas controller settings

The Meldas range of controllers – M3, M32, M300-series and M500-series – use a different configuration of tool offset options to those used by Fanuc.

Set the tool offset type in the setting-data macro (O9760) as follows:

Type 'A' offsets (type 1)	Common type	#108=1
Type 'B' offsets (type 2)	Separate type	#108=2
	Length – geometry	
	Length – wear	
	Radius – geometry	
	Radius – wear	

## Appendix D Mazak controller settings

The Mazak controllers – Fusion 640M and M-Plus – use a different configuration of tool offset options to those used by Fanuc.

Set the tool offset type in the setting-data macro (O9760) as follows:

Mazatrol tool data		#108=1
ISO tool offset Type 'A'	Common type	#108=2
ISO tool data		#108=3
ISO tool offset Type 'B'	Separate type	#108=4

**Renishaw plc**, New Mills, Wotton-under-Edge, Gloucestershire GL12 8JR, UK  
**Tel** +44 (0)1453 524524 [07000 RENISHAW]  
**Fax** +44 (0)1453 524901 **Telex** 437120 RENMET G  
**email** uk@renishaw.com

**Renishaw Inc, USA**  
**Tel** +1 847 286 9953  
**Fax** +1 847 286 9974  
**email** usa@renishaw.com

**Renishaw K.K., Japan**  
**Tel** +81 3 5332 6021  
**Fax** +81 3 5332 6025  
**email** japan@renishaw.com

**Renishaw GmbH, Germany**  
**Tel** +49 7127 9810  
**Fax** +49 7127 88237  
**email** germany@renishaw.com

**Renishaw S.A., France**  
**Tel** +33 1 64 61 84 84  
**Fax** +33 1 64 61 65 26  
**email** france@renishaw.com

**Renishaw S.p.A., Italy**  
**Tel** +39 011 9 66 10 52  
**Fax** +39 011 9 66 40 83  
**email** italy@renishaw.com

**Renishaw Iberica S.A., Spain**  
**Tel** +34 93 478 21 31  
**Fax** +34 93 478 16 08  
**email** spain@renishaw.com

**Renishaw A.G., Switzerland**  
**Tel** +41 55 410 66 66  
**Fax** +41 55 410 66 69  
**email** switzerland@renishaw.com

**Renishaw Latino Americana Ltda., Brazil**  
**Tel** +55 11 7295 2866  
**Fax** +55 11 7295 1641  
**email** brazil@renishaw.com

**Renishaw (Hong Kong) Ltd., Hong Kong, The People's Republic of China**  
**Tel** +852 2753 0638  
**Fax** +852 2756 8786  
**email** hongkong@renishaw.com

**Renishaw Metrology Systems Private Limited, India**  
**Tel** +91 80 5320 144  
**Fax** +91 80 5320 140  
**email** india@renishaw.com

### Renishaw's Representative Offices

**Australia** **Tel** +61 3 9553 8267  
**Fax** +61 3 9592 6738  
**email** australia@renishaw.com

**Indonesia** **Tel** +62 21 428 70153  
**Fax** +62 21 424 3934  
**email** indonesia@renishaw.com

**Singapore** **Tel** +65 897 5466  
**Fax** +65 897 5467  
**email** singapore@renishaw.com

**Taiwan** **Tel** +886 4 2513665  
**Fax** +886 4 2513621  
**email** taiwan@renishaw.com

**The People's Republic of China**  
**Tel** +86 10 641 07993  
**Fax** +86 10 641 07992  
**email** china@renishaw.com

### Renishaw's Liaison Office

**South Korea** **Tel** +82 2 565 6878  
**Fax** +82 2 565 6879  
**email** southkorea@renishaw.com

**RENISHAW**  <sup>®</sup>  
[www.renishaw.com](http://www.renishaw.com)