

# Equator-X tile spacer kit

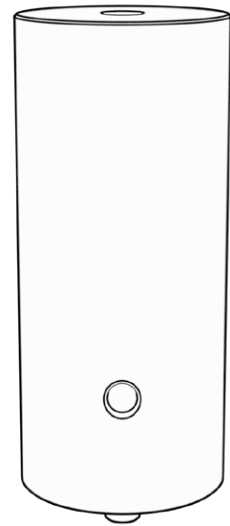
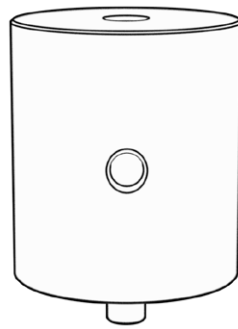
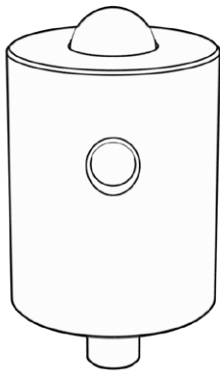

## REACH regulation

Information required by Article 33(1) of Regulation (EC) No. 1907/2006 ("REACH") relating to products containing substances of very high concern (SVHCs) is available at: [www.renishaw.com/REACH](http://www.renishaw.com/REACH)

## Nařízení REACH

Informace vyžadované článkem 33(1) nařízení (ES) č. 1907/2006 („REACH“) vztahující se na výrobky obsahující vysoce nebezpečné látky (Substances of Very High Concern – SVHC) jsou uvedeny na [www.renishaw.cz/REACH](http://www.renishaw.cz/REACH)

## REACH-Verordnung

Die gemäß Artikel 33(1) der Verordnung (EG) Nr. 1907/2006 („REACH“-Verordnung) erforderlichen Informationen zu Produkten, die besonders besorgniserregende Stoffe (SVHC) enthalten, erhalten Sie unter:  
[www.renishaw.de/REACH](http://www.renishaw.de/REACH)

## Regulación REACH

Puede consultar la información sobre los requisitos del Artículo 33(1) del reglamento europeo N.º 1907/2006 ("REACH") para productos que contienen sustancias alarmantes (SVHC) en: [www.renishaw.es/REACH](http://www.renishaw.es/REACH)

## Règlement REACH

Les informations requises aux termes de l'Article 33(1) de la Règlementation CE n° 1907/2006 (« REACH », Enregistrement, Évaluation et Autorisation des substances Chimiques) concernant les produits contenant des substances extrêmement préoccupantes (Substances of Very High Concern - SVHC) sont disponibles sur le site [www.renishaw.fr/REACH](http://www.renishaw.fr/REACH)

## Regolamento REACH

Le informazioni richieste dall'articolo 33(1) del regolamento (CE) N. 1907/2006 ("REACH") relativa ai prodotti contenenti sostanze estremamente preoccupanti (SVHC) sono disponibili al seguente indirizzo:  
[www.renishaw.it/REACH](http://www.renishaw.it/REACH)

## REACH 規則

高懸念物質 (Substances of Very High Concern, SVHC) を含む製品に関する規則 (EC) No. 1907/2006 (REACH) の第 33(1) 項で要求される情報については、[www.renishaw.jp/REACH](http://www.renishaw.jp/REACH) を参照してください

## REACH 규정

고위험성 우려 후보물질 (Substances of Very High Concern - SVHC)을 포함한 제품과 관련된 규정 (EC) No. 1907/2006("REACH")의 33(1)항에 따라 요구되는 정보는 [www.renishaw.co.kr/REACH](http://www.renishaw.co.kr/REACH)에서 확인하실 수 있습니다.

## Regulacja REACH

Informacje wymagane na mocy art. 33 ust. 1 Regulacji (EC) nr 1907/2006 („REACH“) dotyczącej produktów zawierających substancje stanowiące bardzo duże zagrożenie (Substances of Very High Concern — SVHC) są dostępne pod adresem: [www.renishaw.pl/REACH](http://www.renishaw.pl/REACH)

## Регламент ЕС (REACH)

Сведения, предусмотренные Ст. 33(1) Регламента (EC) № 1907/2006 (REACH) для изделий, содержащих особо опасные вещества (SVHC), приведены на веб-странице: [www.renishaw.ru/REACH](http://www.renishaw.ru/REACH)

## REACH-förordningen

Obligatorisk information enligt artikel 33(1) i EG-förordning nr 1907/2006 ("REACH") om produkter som innehåller farliga ämnen (SVHC–Substances of Very High Concern) hittar du på: [www.renishaw.se/REACH](http://www.renishaw.se/REACH)

## REACH法规

如需获取第1907/2006 (EC) 号法规 ( "REACH" ) 之第33(1) 条针对含有高度关注物质 (SVHC) 的产品要求提供的信息, 请访问[www.renishaw.com.cn/REACH](http://www.renishaw.com.cn/REACH)

# Contents

- Kit contents. . . . . 4
- Introduction. . . . . 5
- Kinematic spacer configurations. . . . . 6
  - Ball spacer . . . . . 6
  - 50 mm spacer + ball spacer. . . . . 8
  - 100 mm spacer + ball spacer. . . . . 11
- Fixed spacer configurations . . . . . 14
  - 50 mm spacer. . . . . 14
  - 100 mm spacer. . . . . 17

## Kit contents

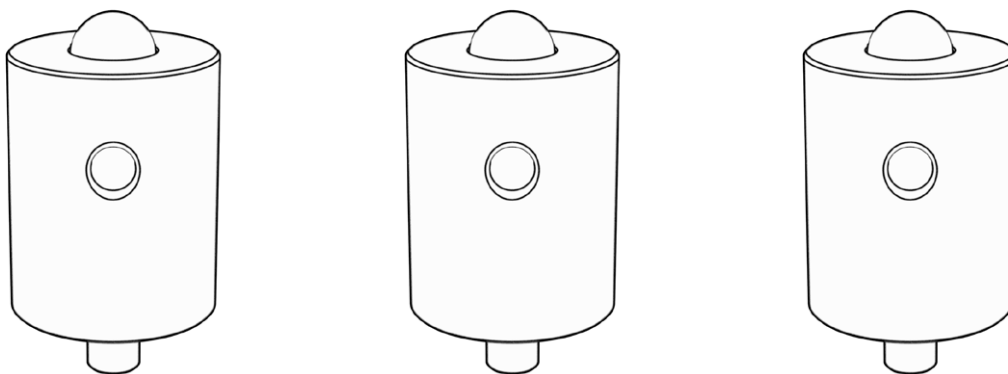

**Ball spacer x 3**

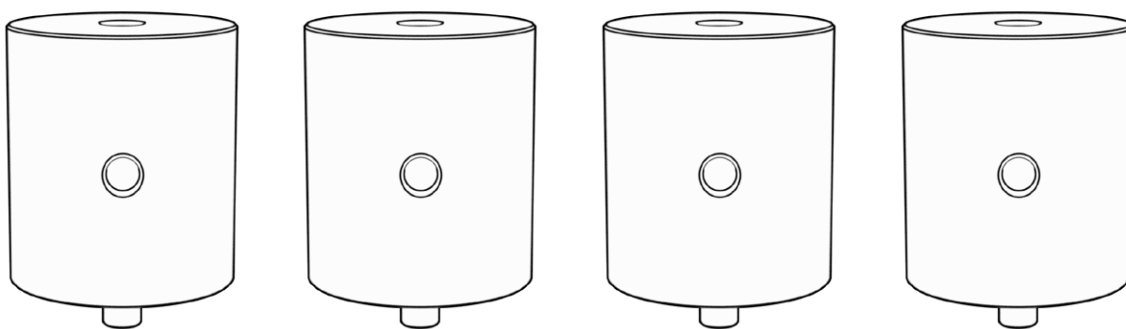

**50 mm spacer x 4**

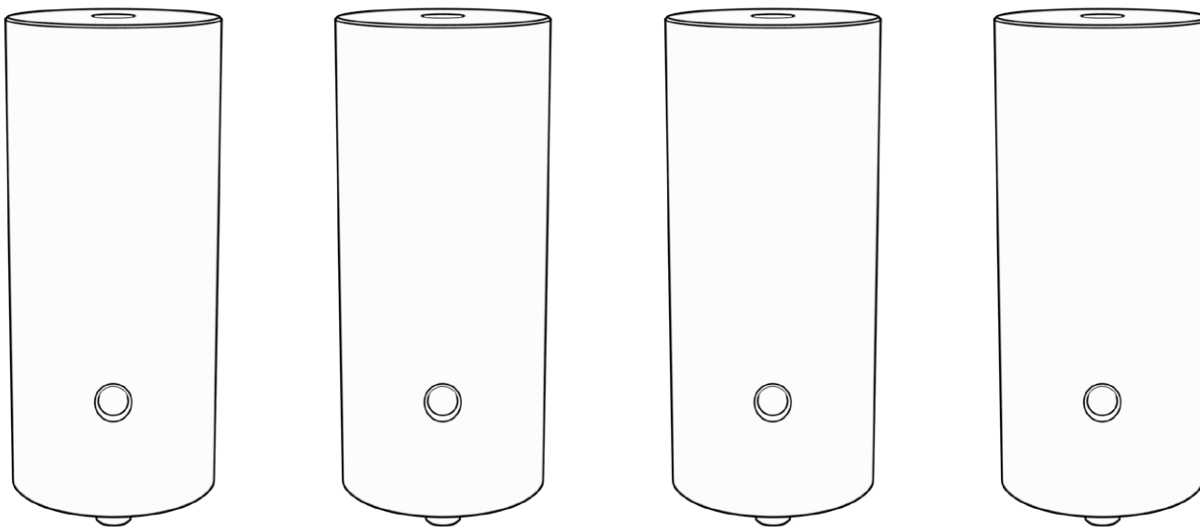

**100 mm spacer x 4**

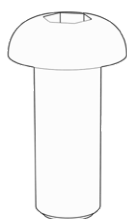

**M8x20 hex button screw x 4**

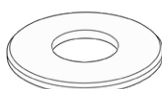

**M8 washers form A x 4**



**1.5 mm hex key**

## Introduction

The spacers can be used with or without a manual transfer system (MTS).

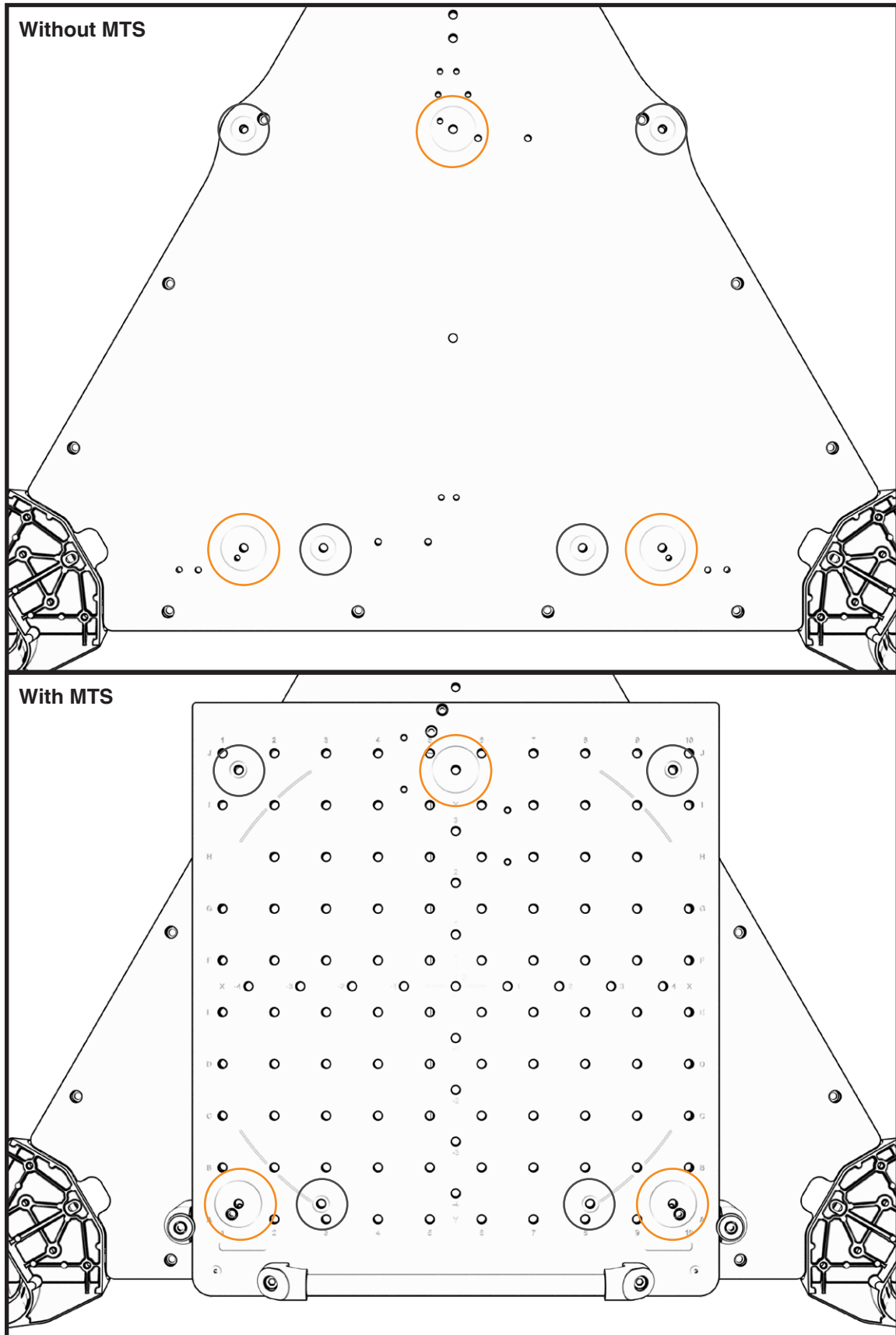

# Kinematic spacer configurations

## Ball spacer

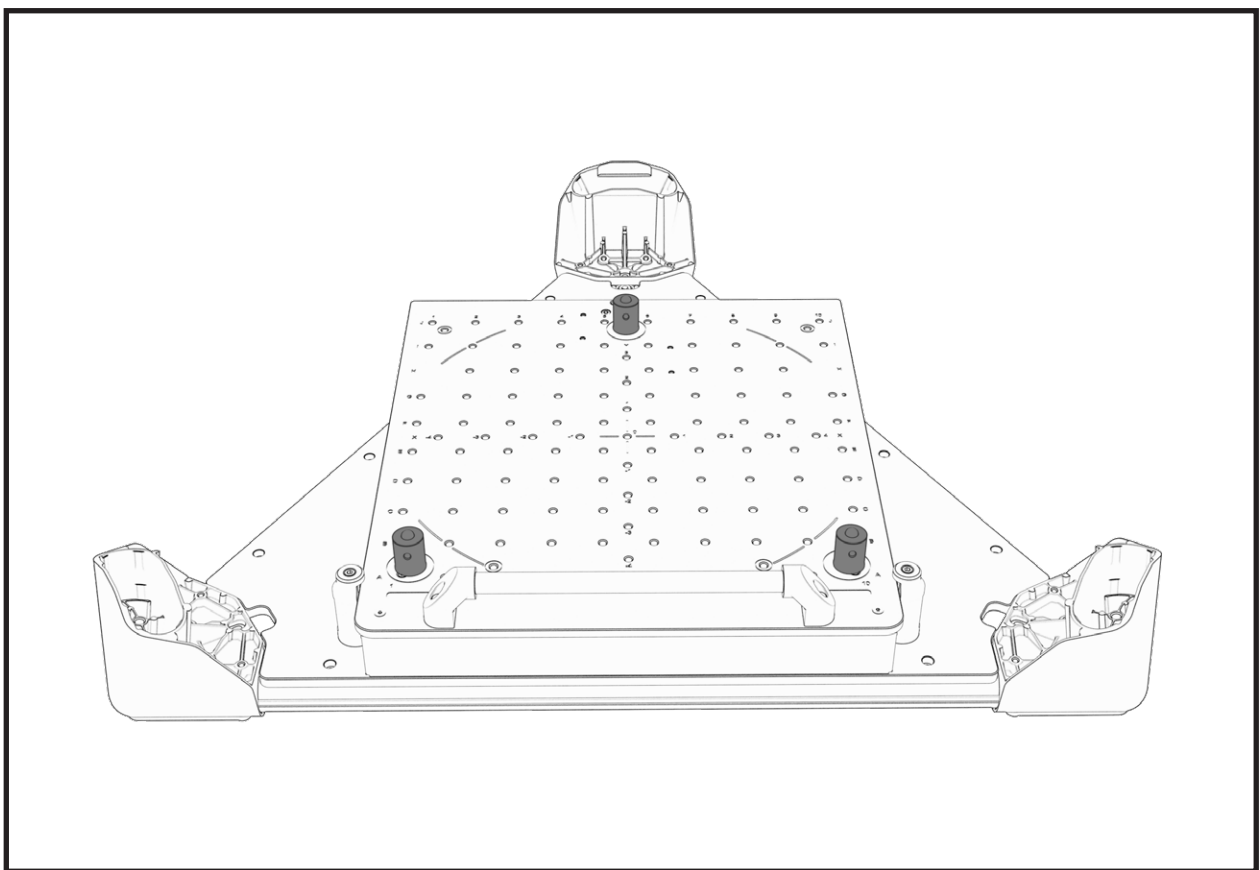
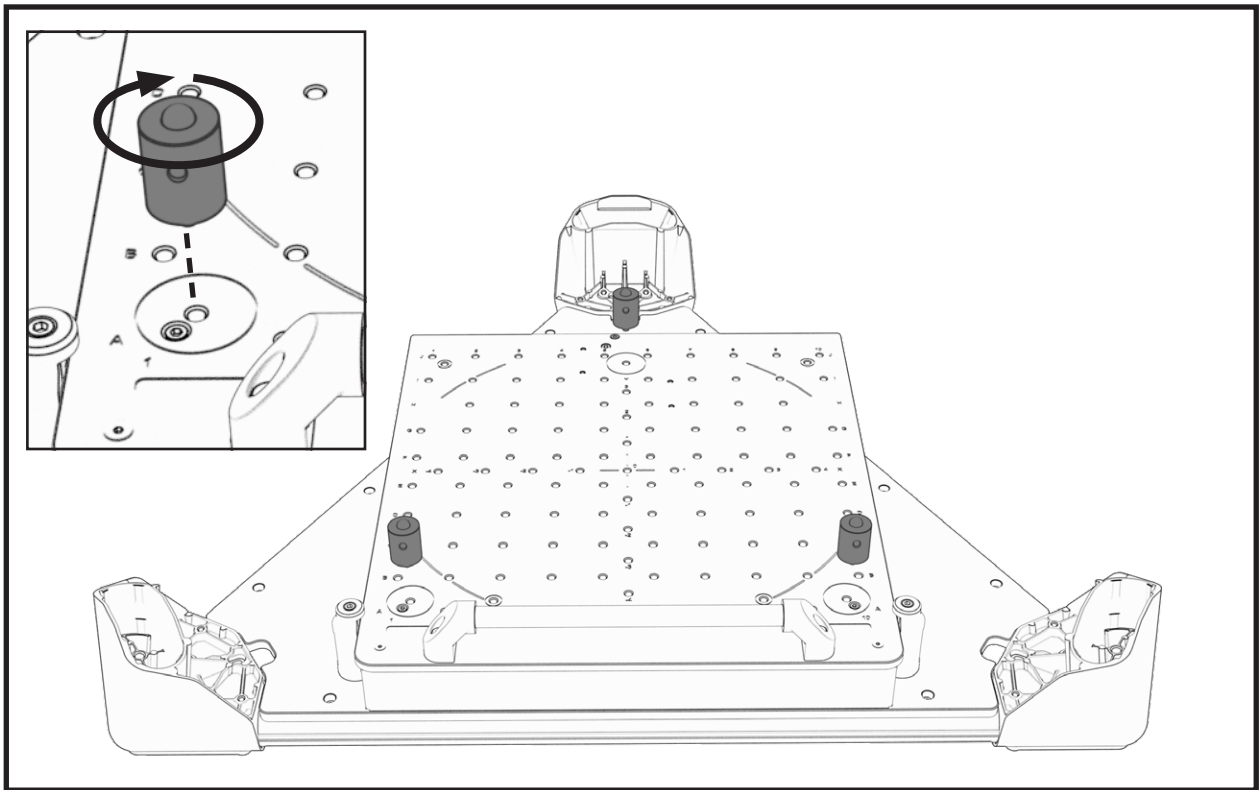

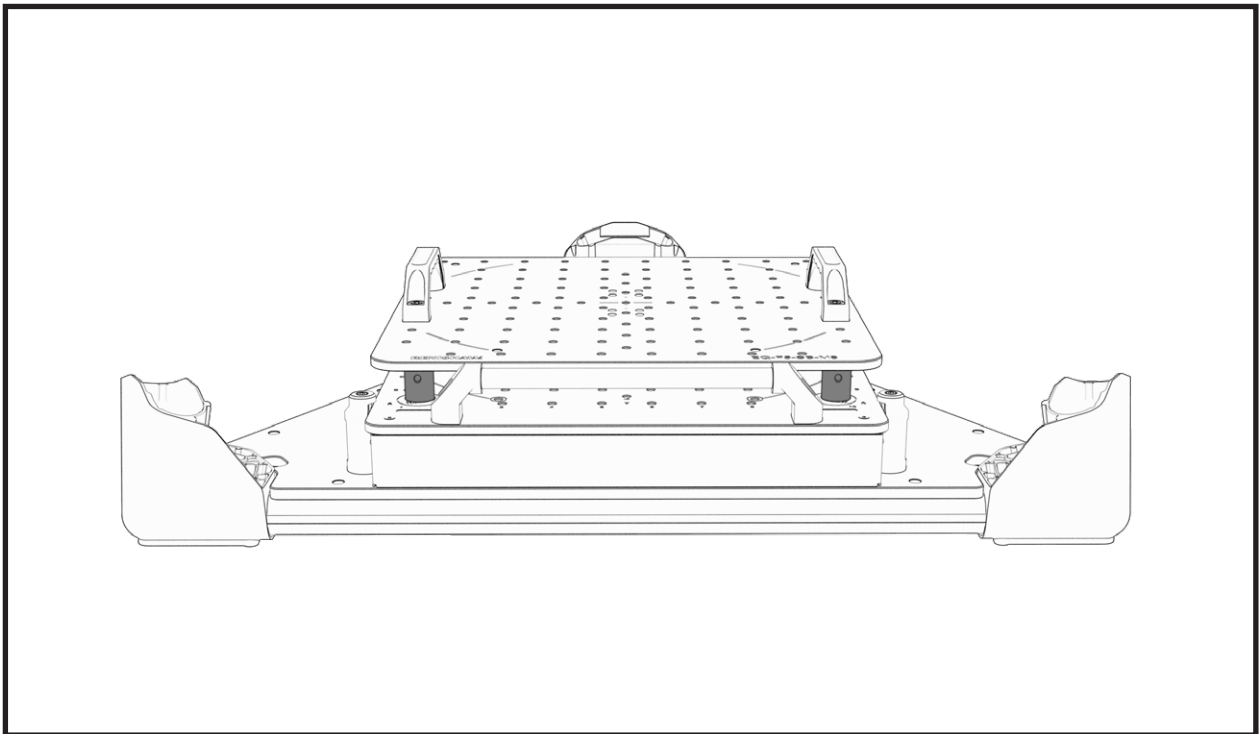
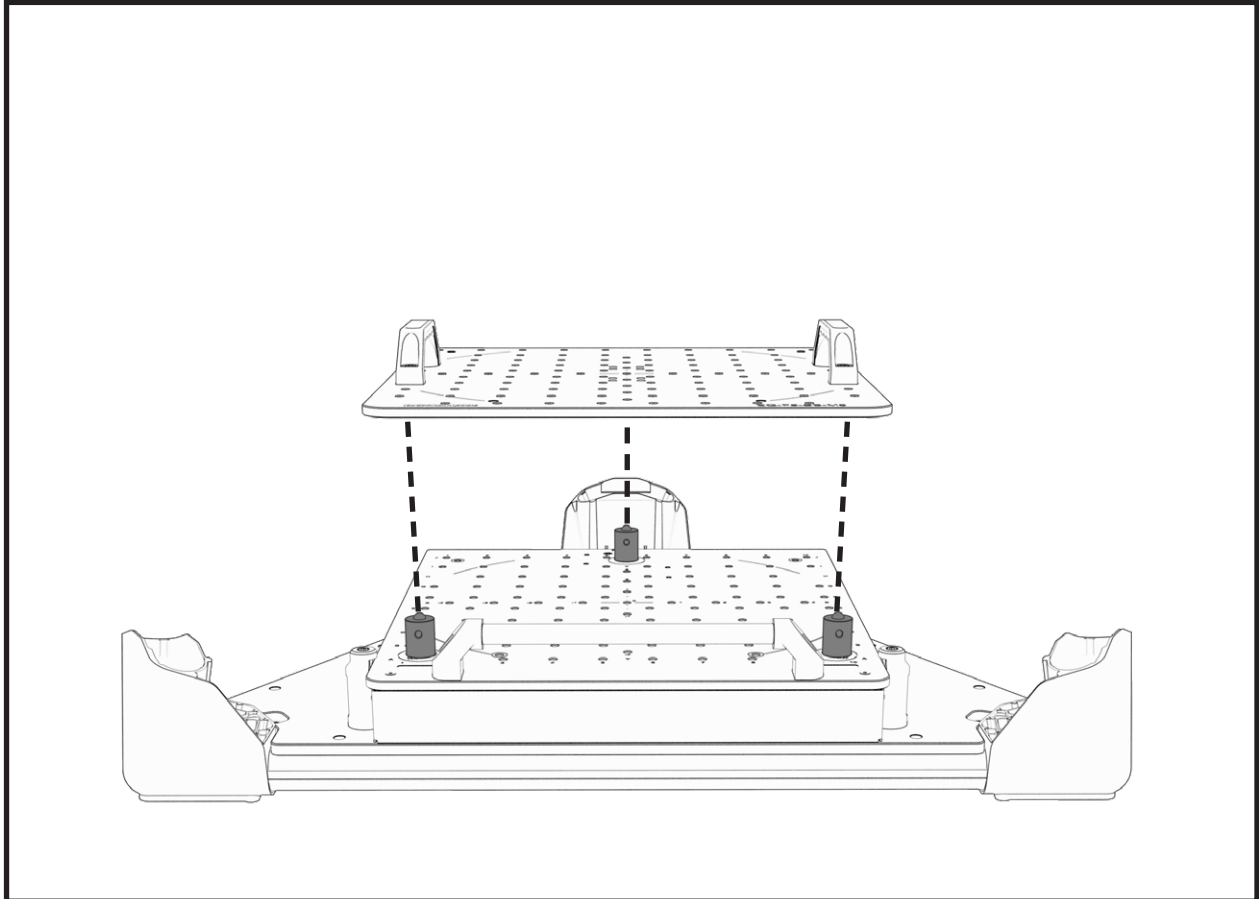

Ball spacer configuration	
Available loading mass	17.8 kg
Tile height	33 mm below working volume

**50 mm spacer + ball spacer**

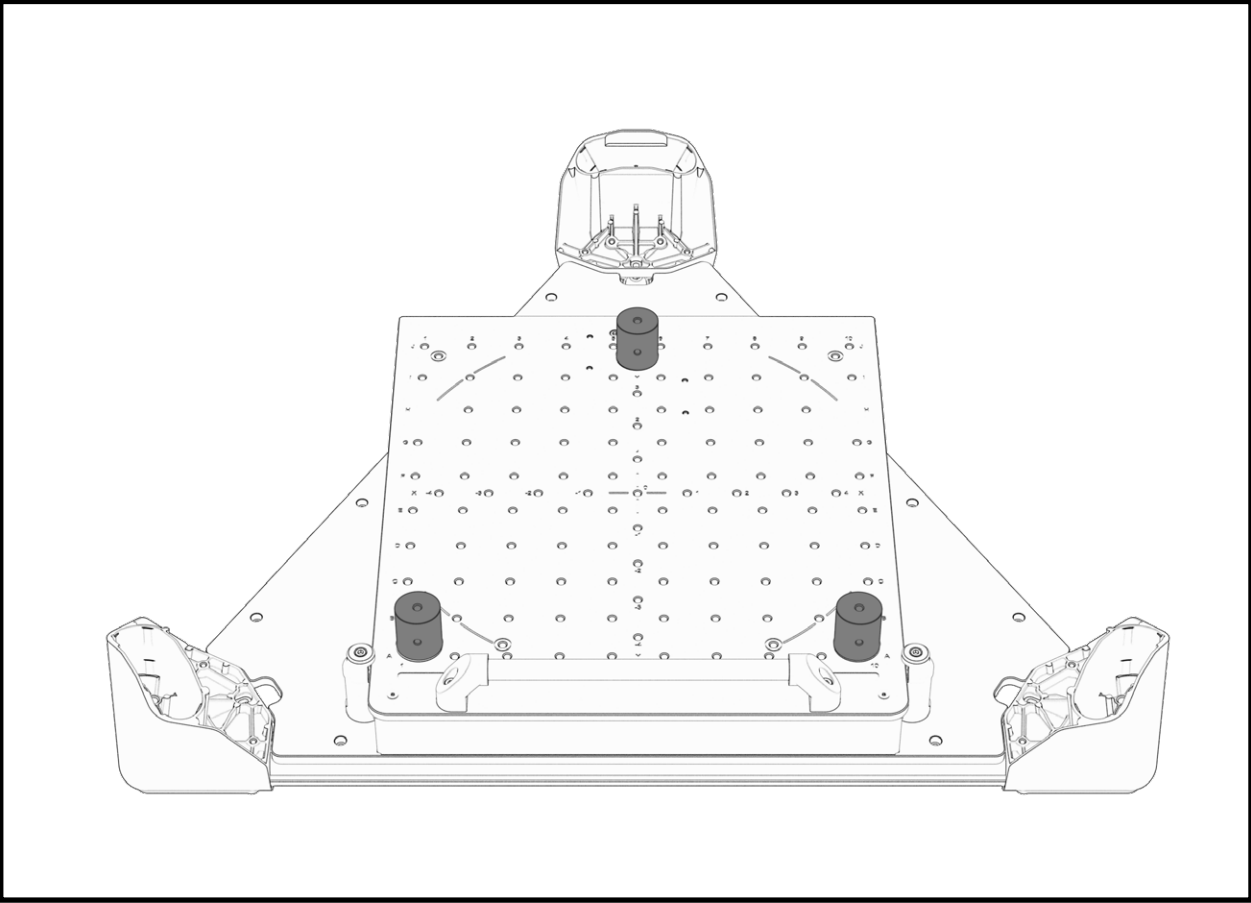
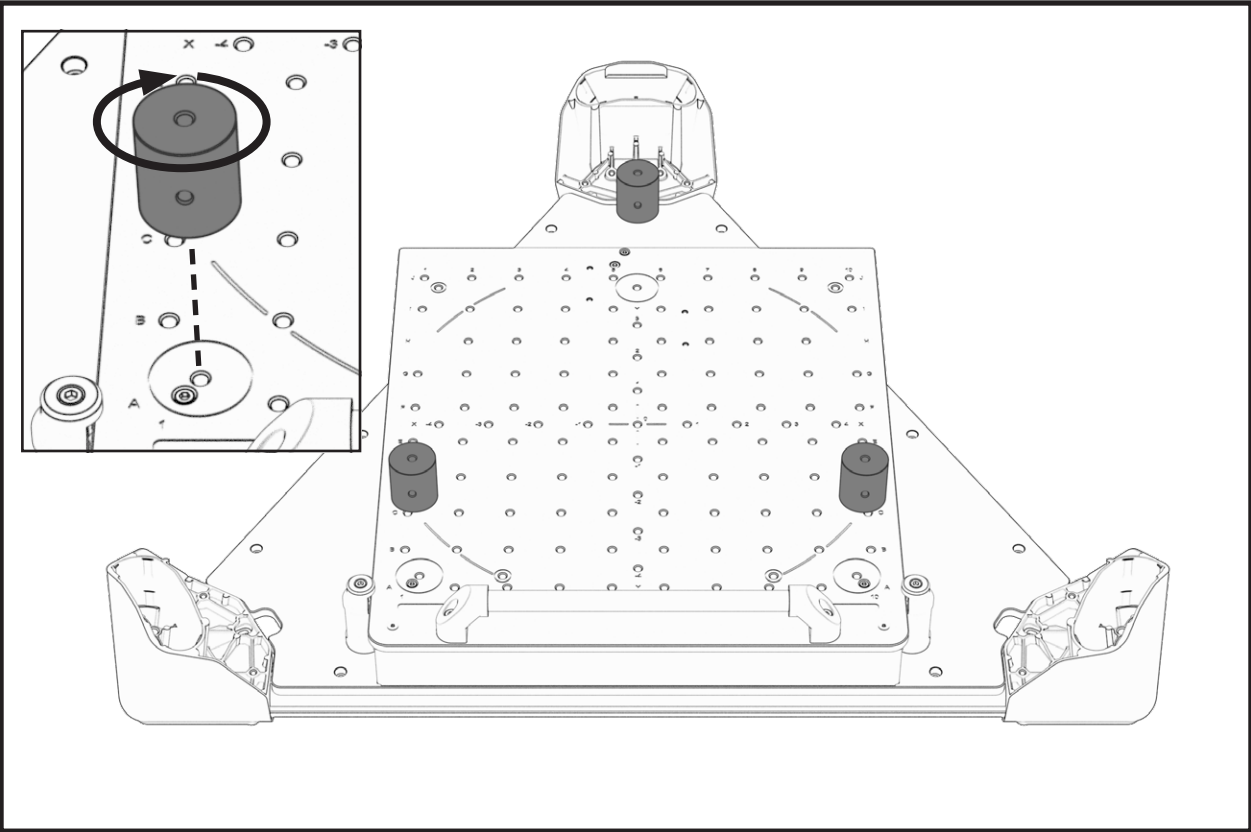

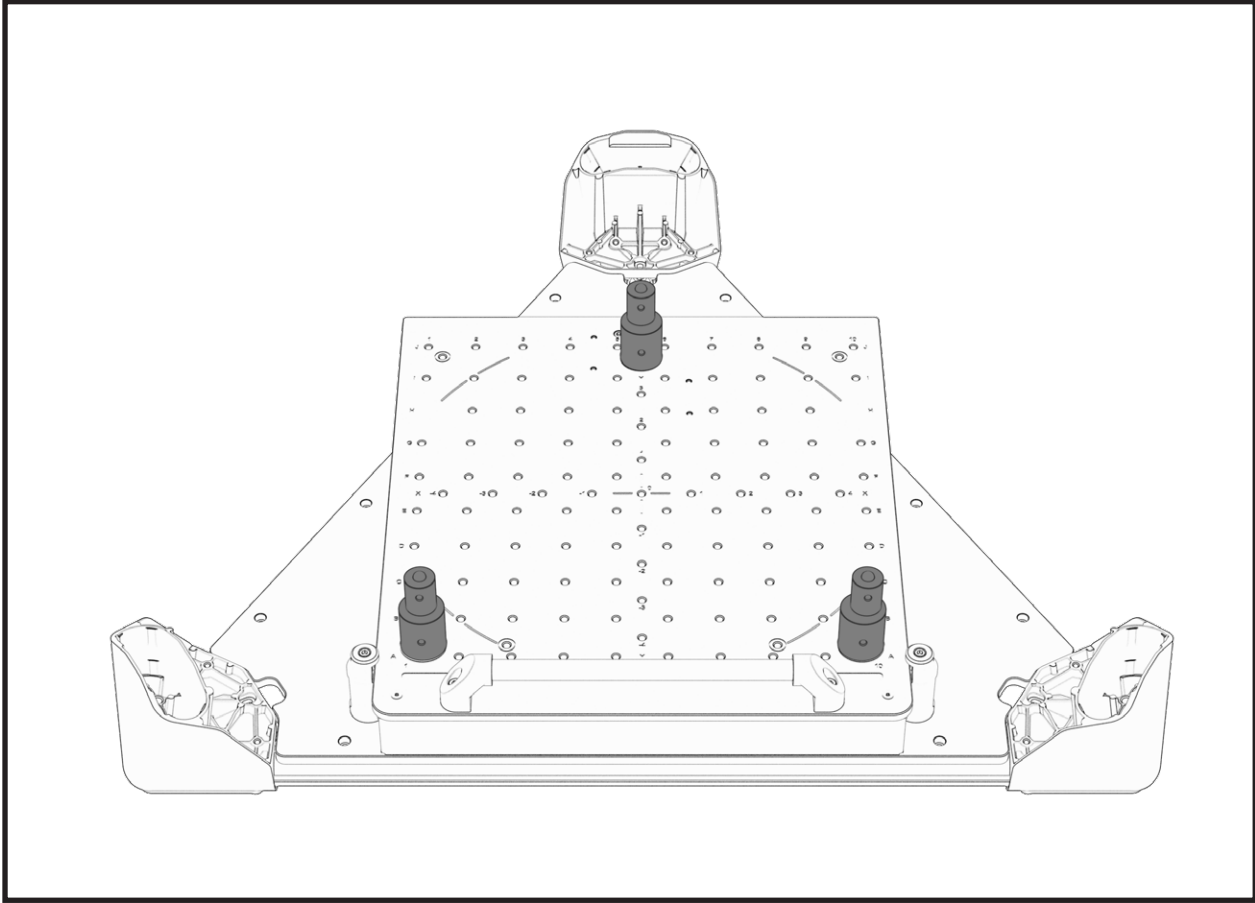
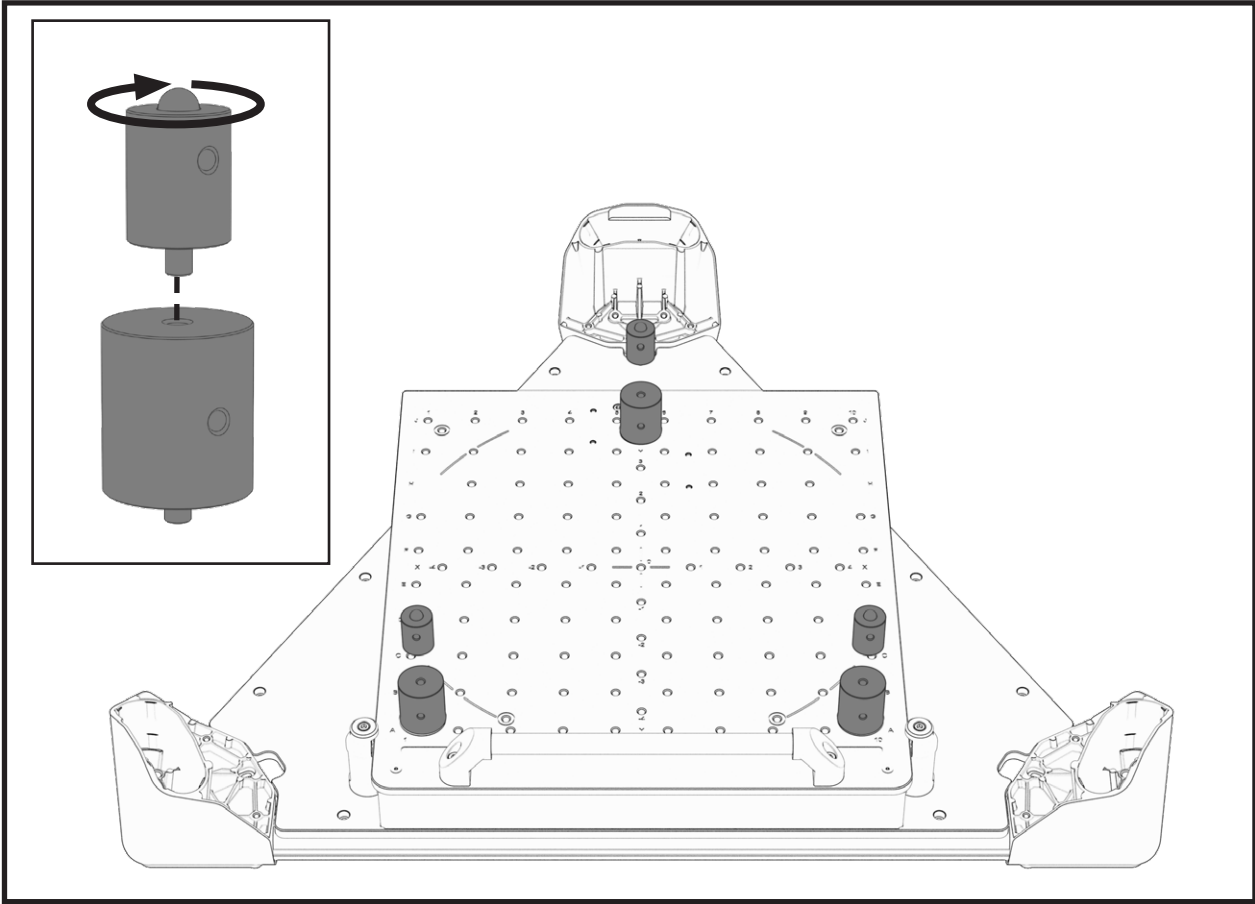

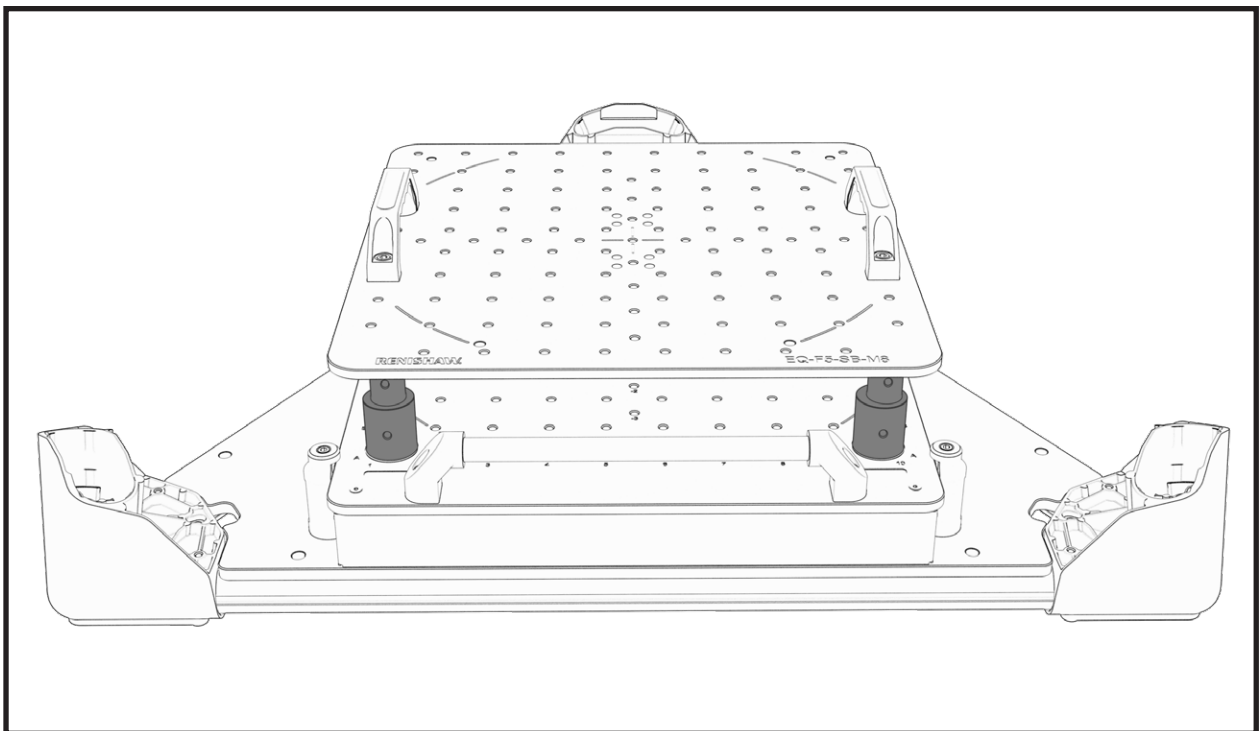
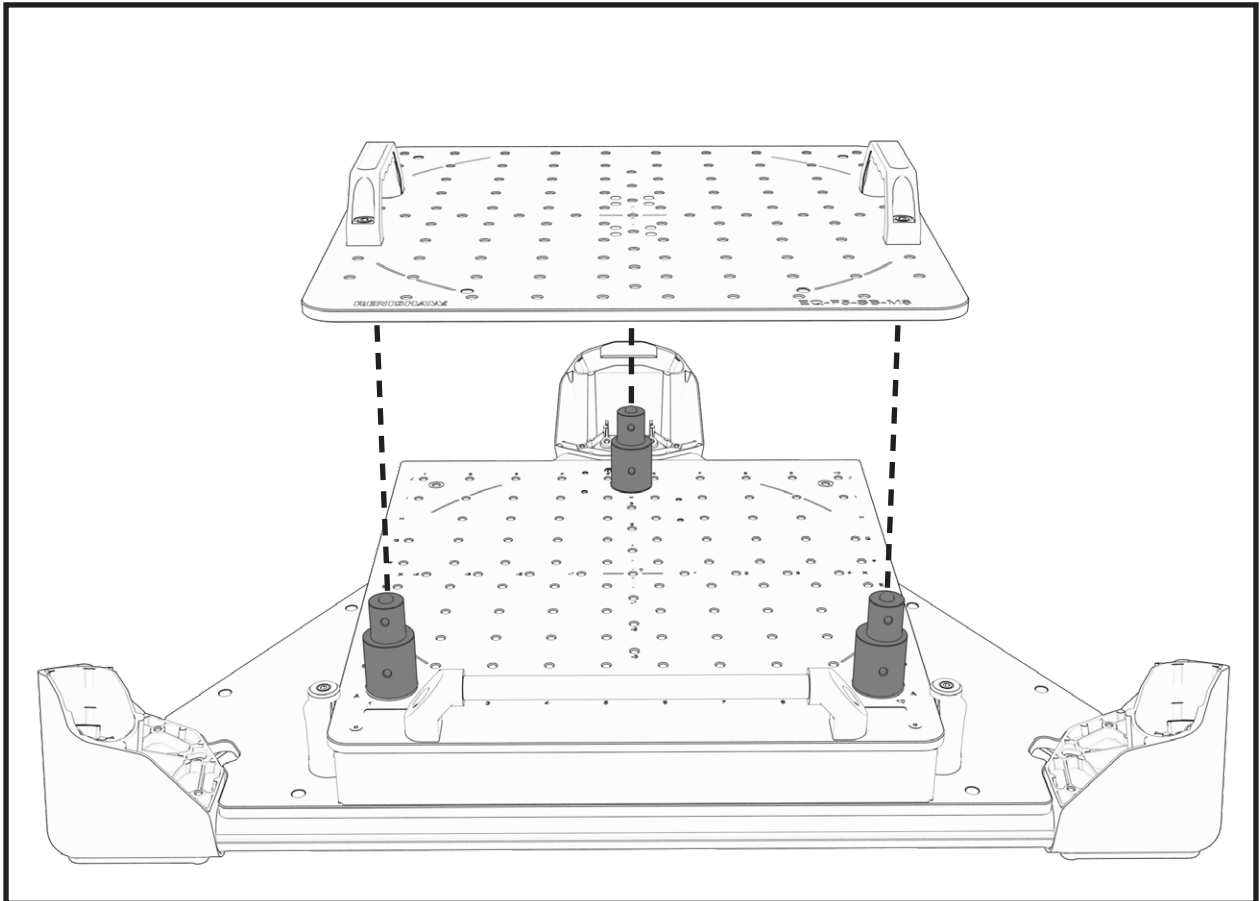

50 mm spacer + ball spacer configuration	
Available loading mass	17.3 kg
Tile height	15.5 mm inside working volume

**100 mm spacer + ball spacer**

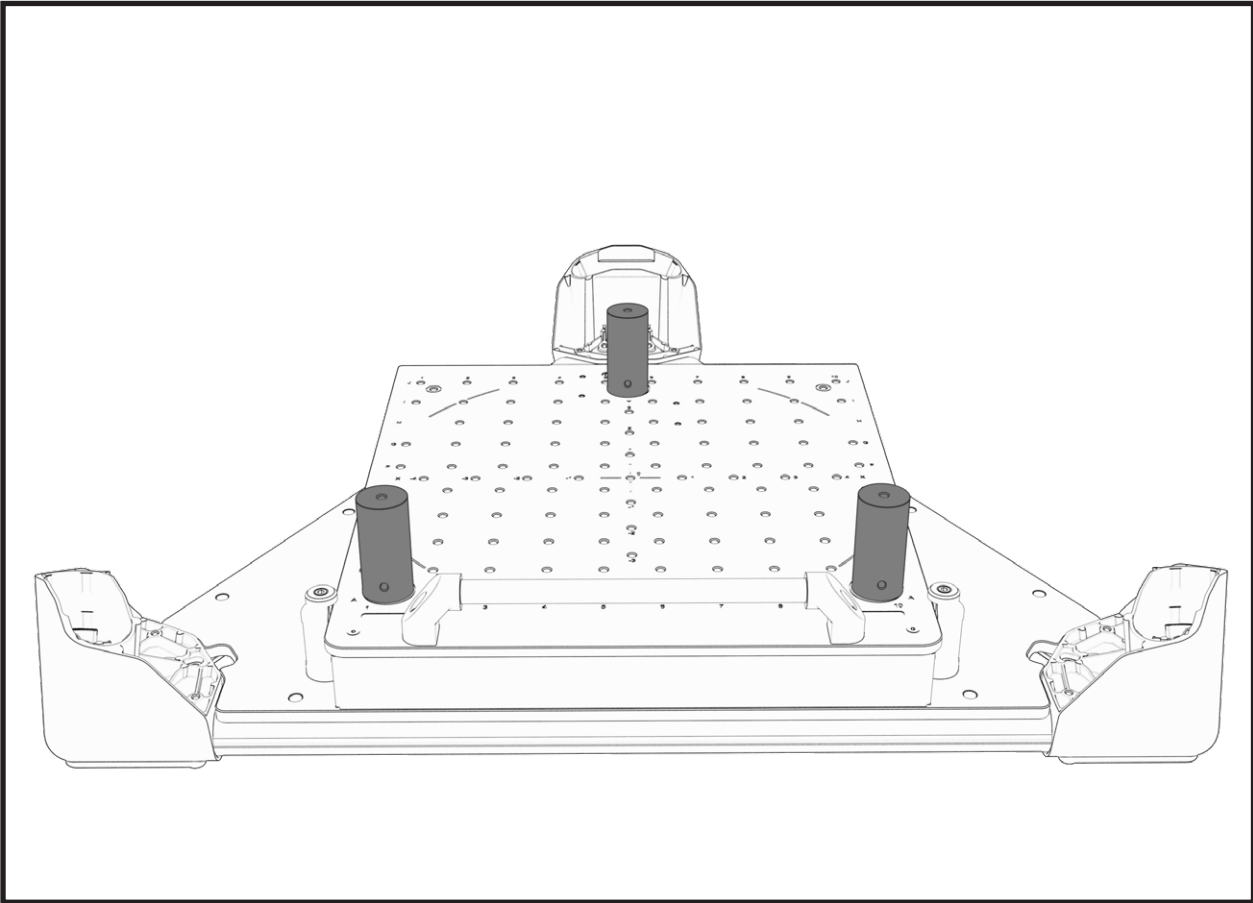
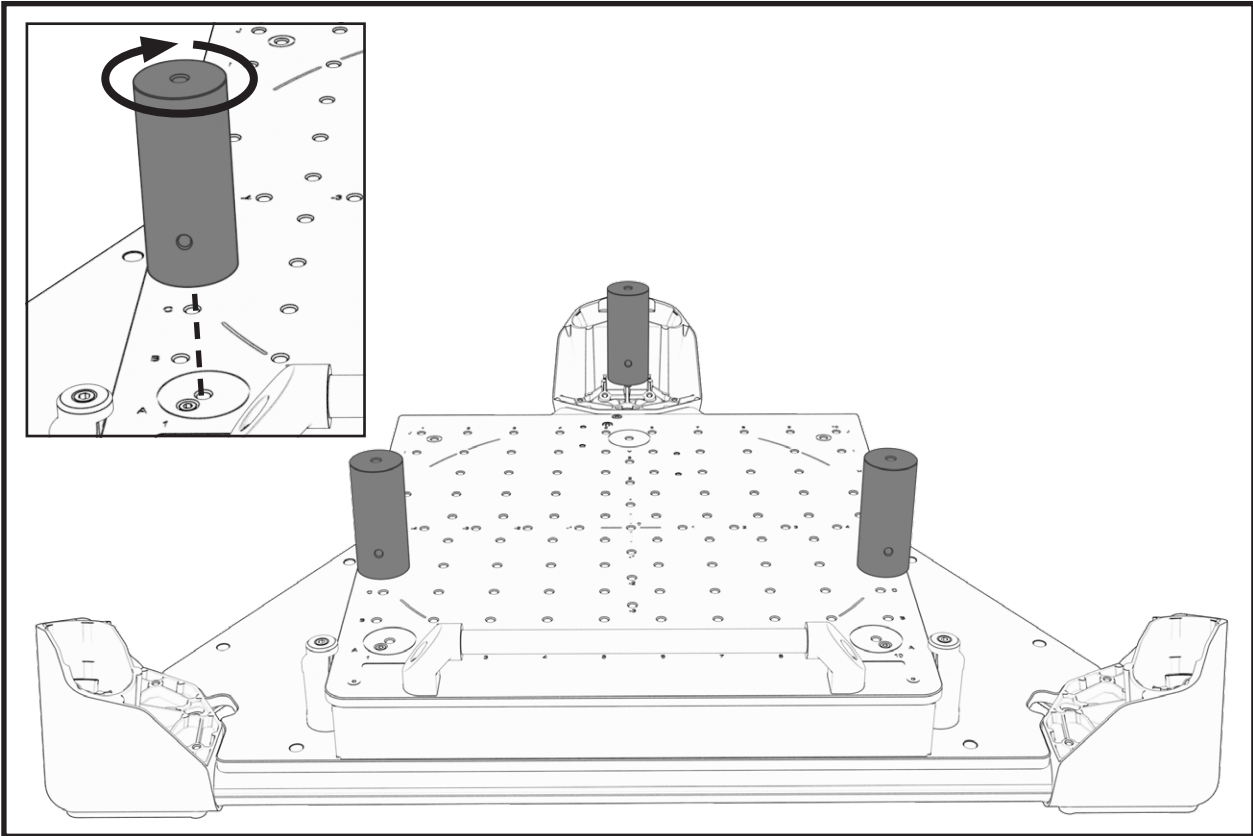

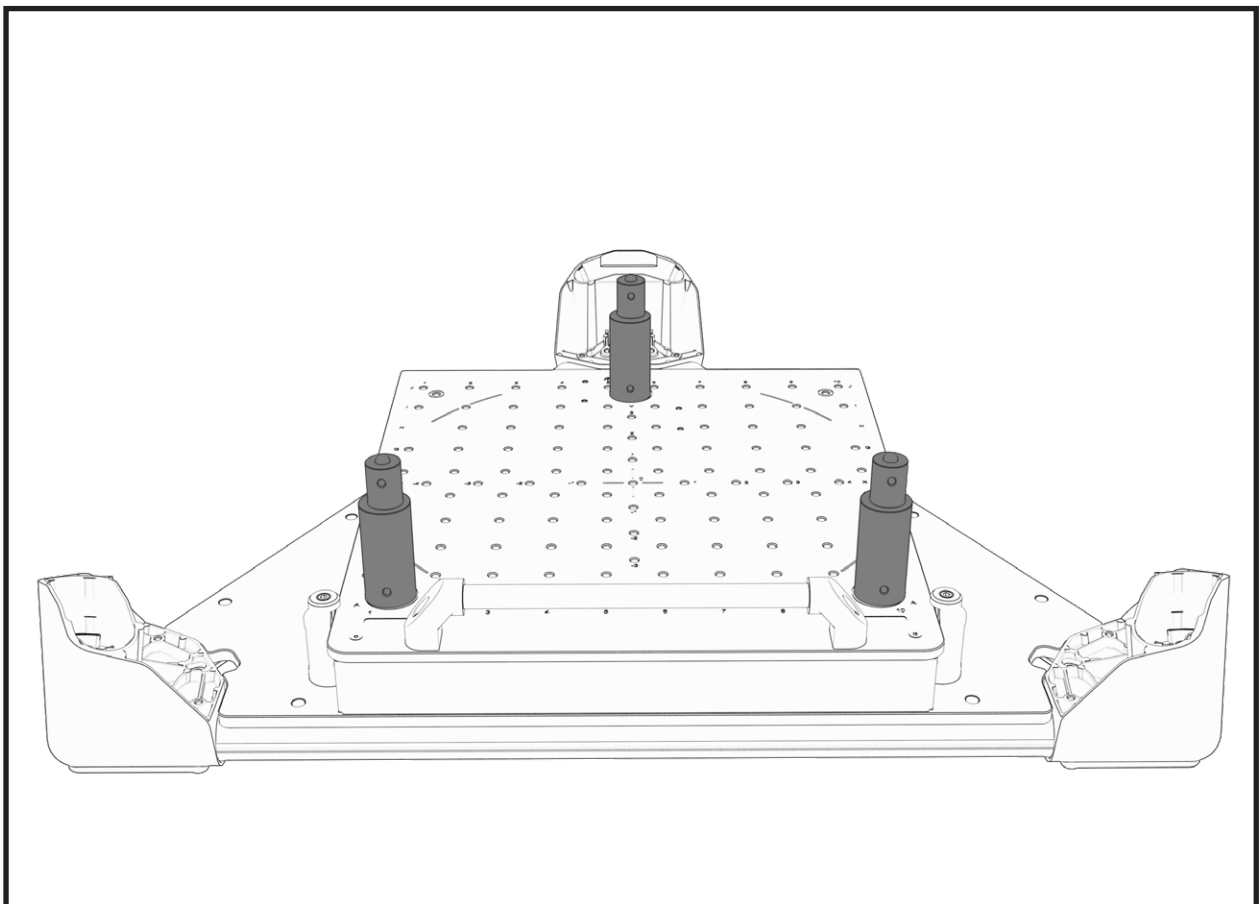
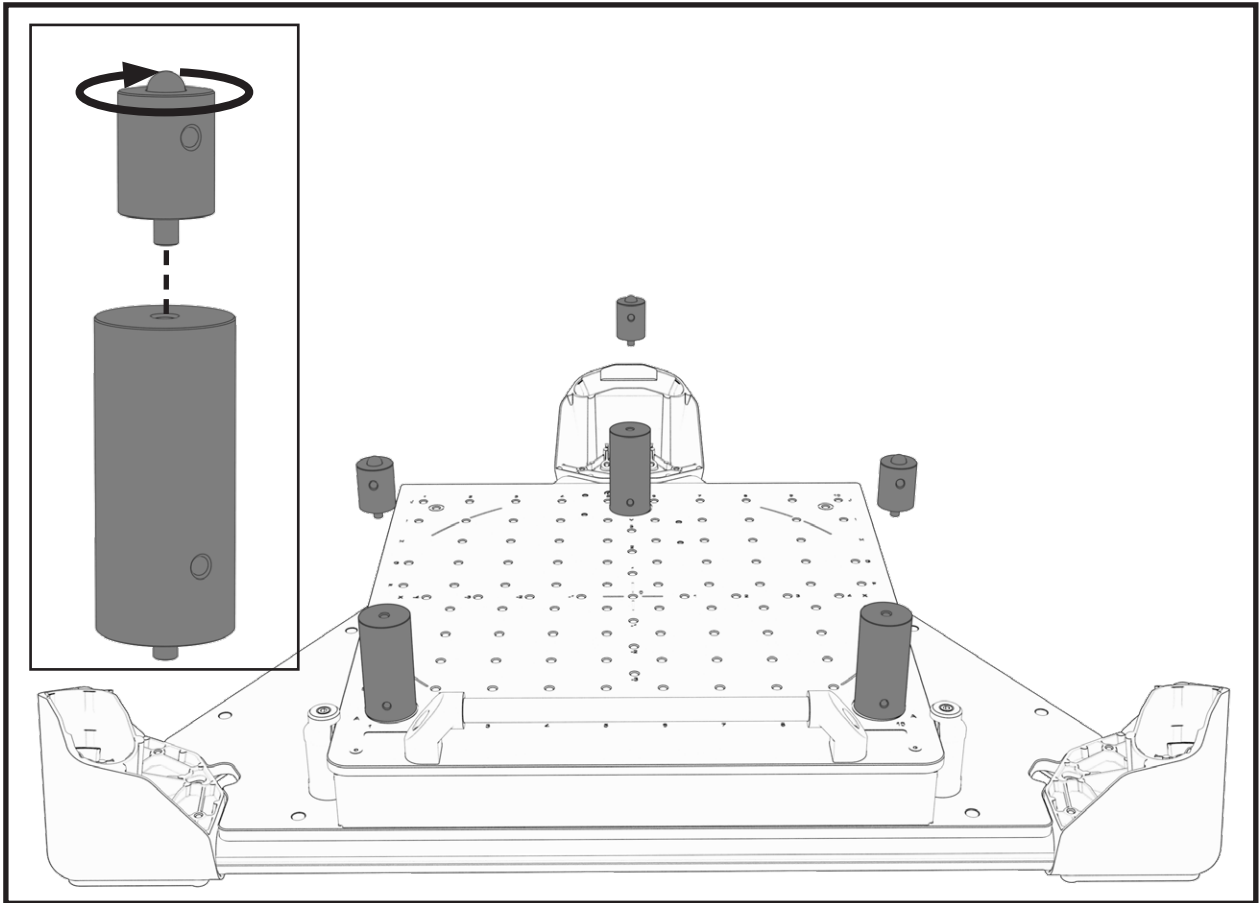

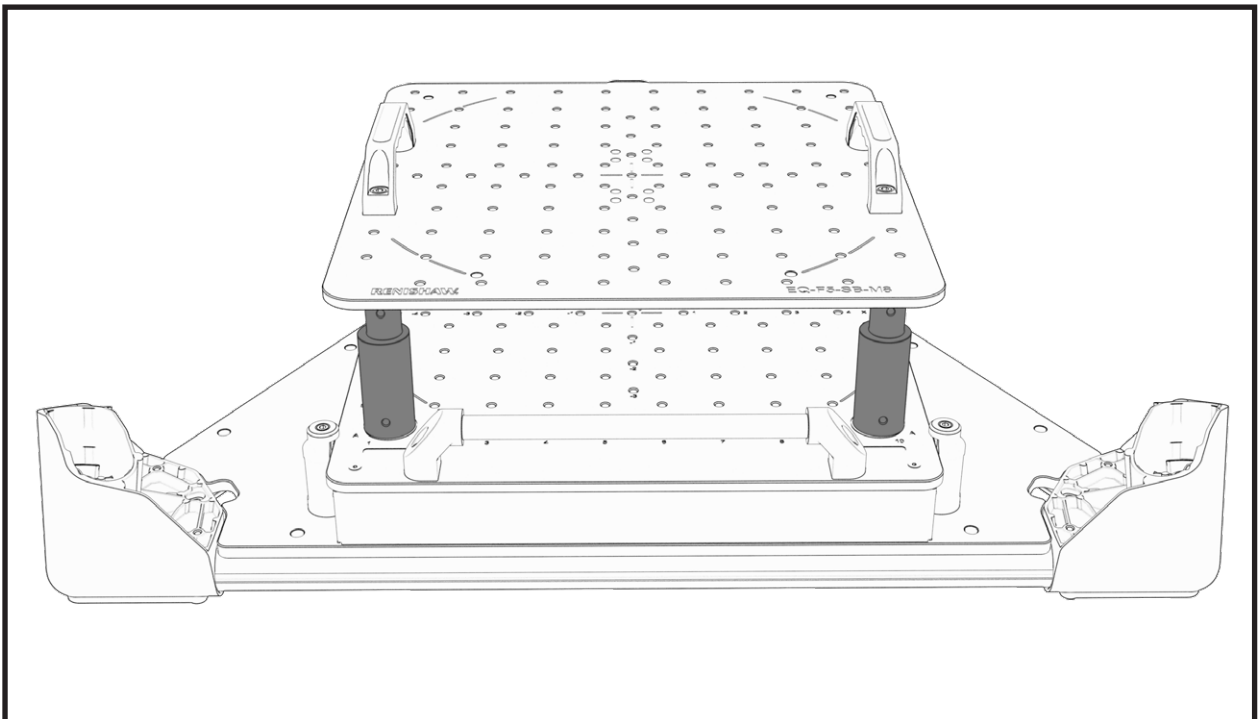
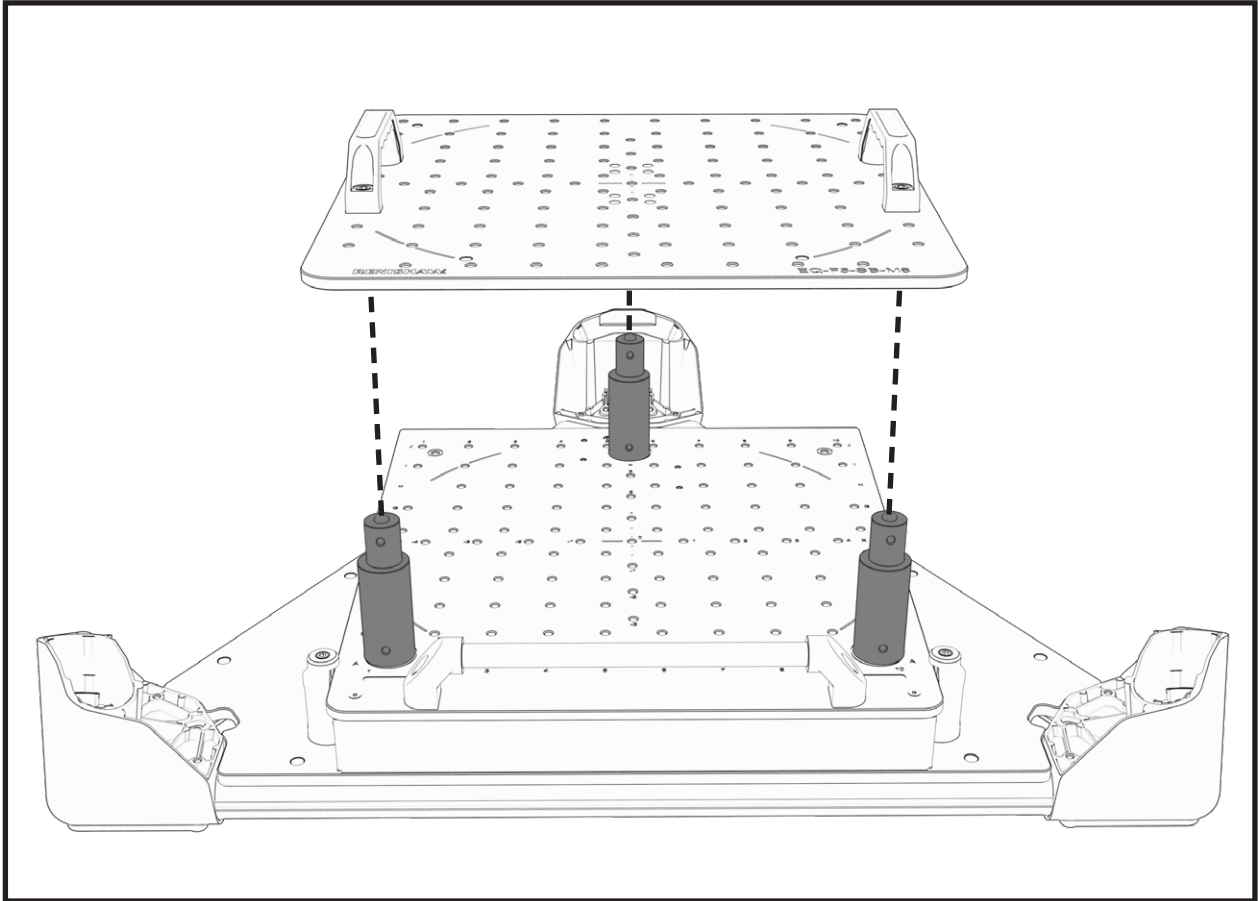

**100 mm spacer + ball spacer configuration**

<b>Available loading mass</b>	16.7 kg
<b>Tile height</b>	65.5 mm inside working volume

# Fixed spacer configurations

## 50 mm spacer

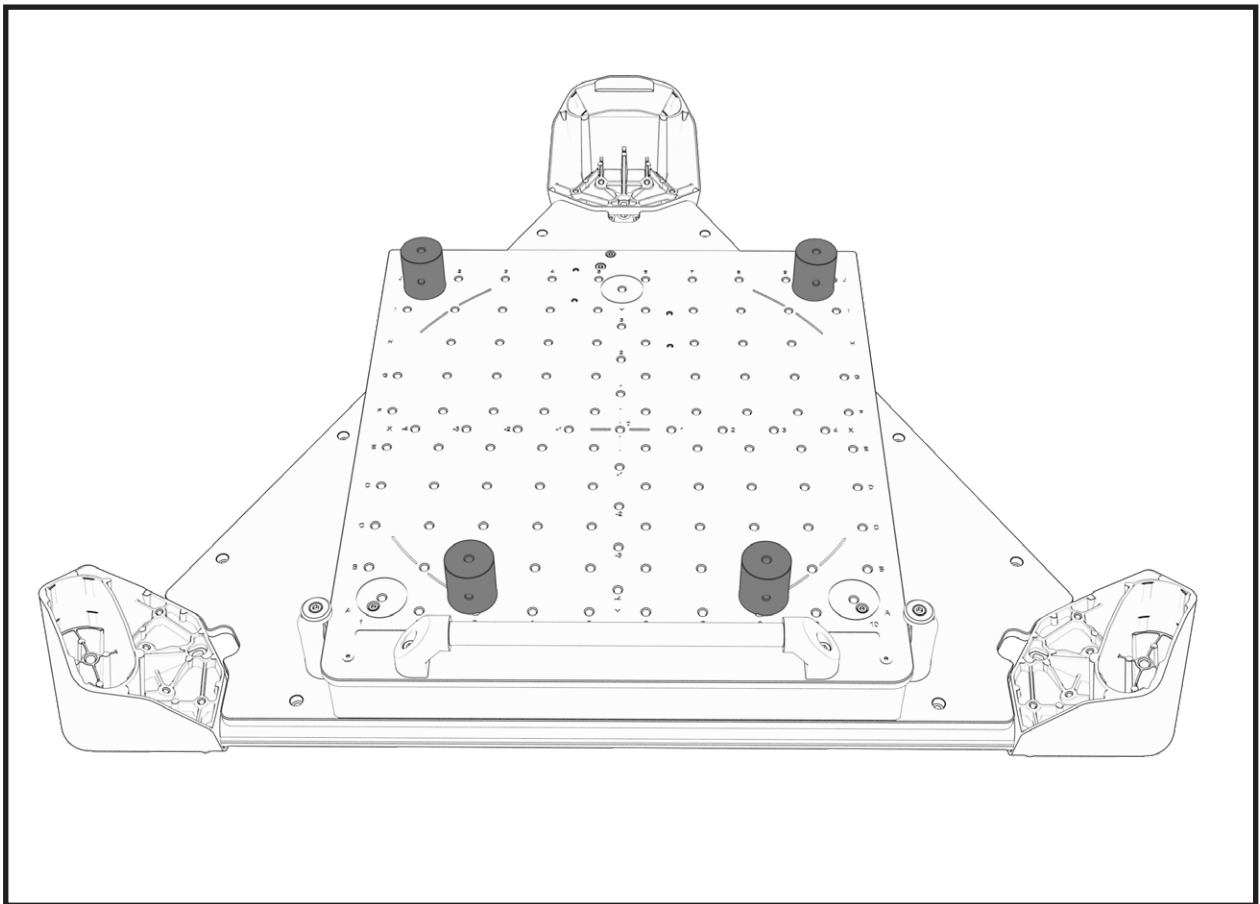
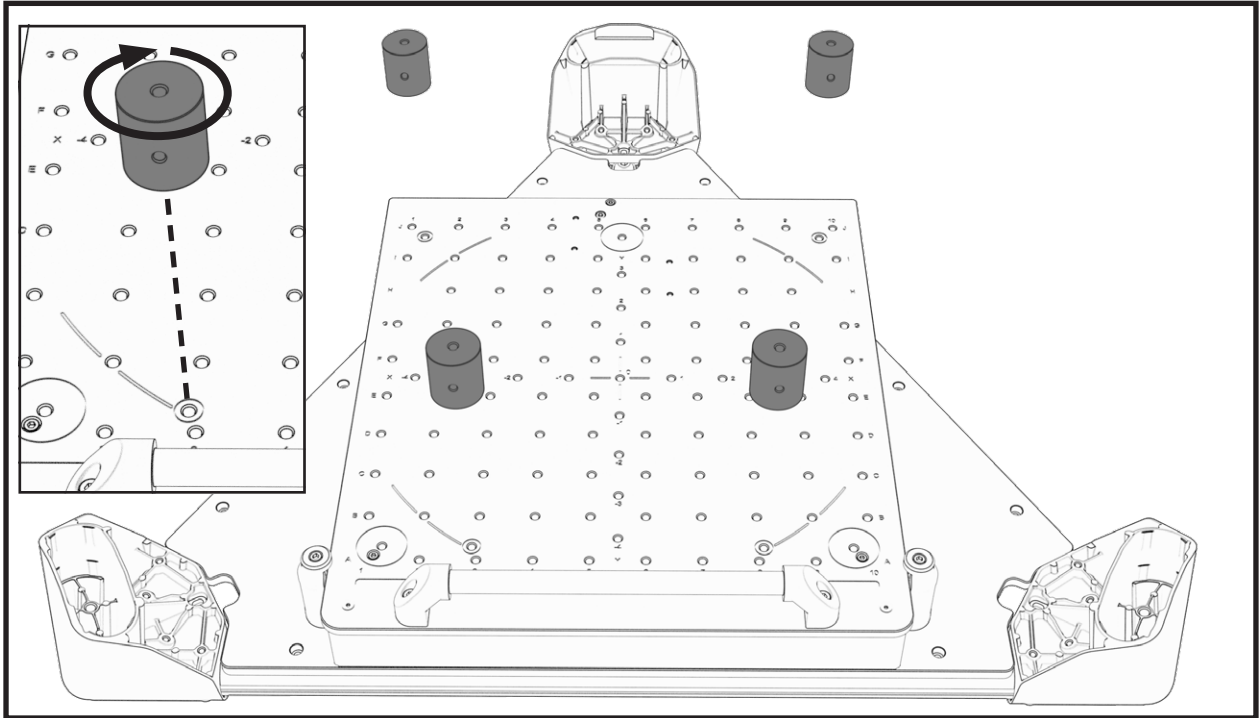

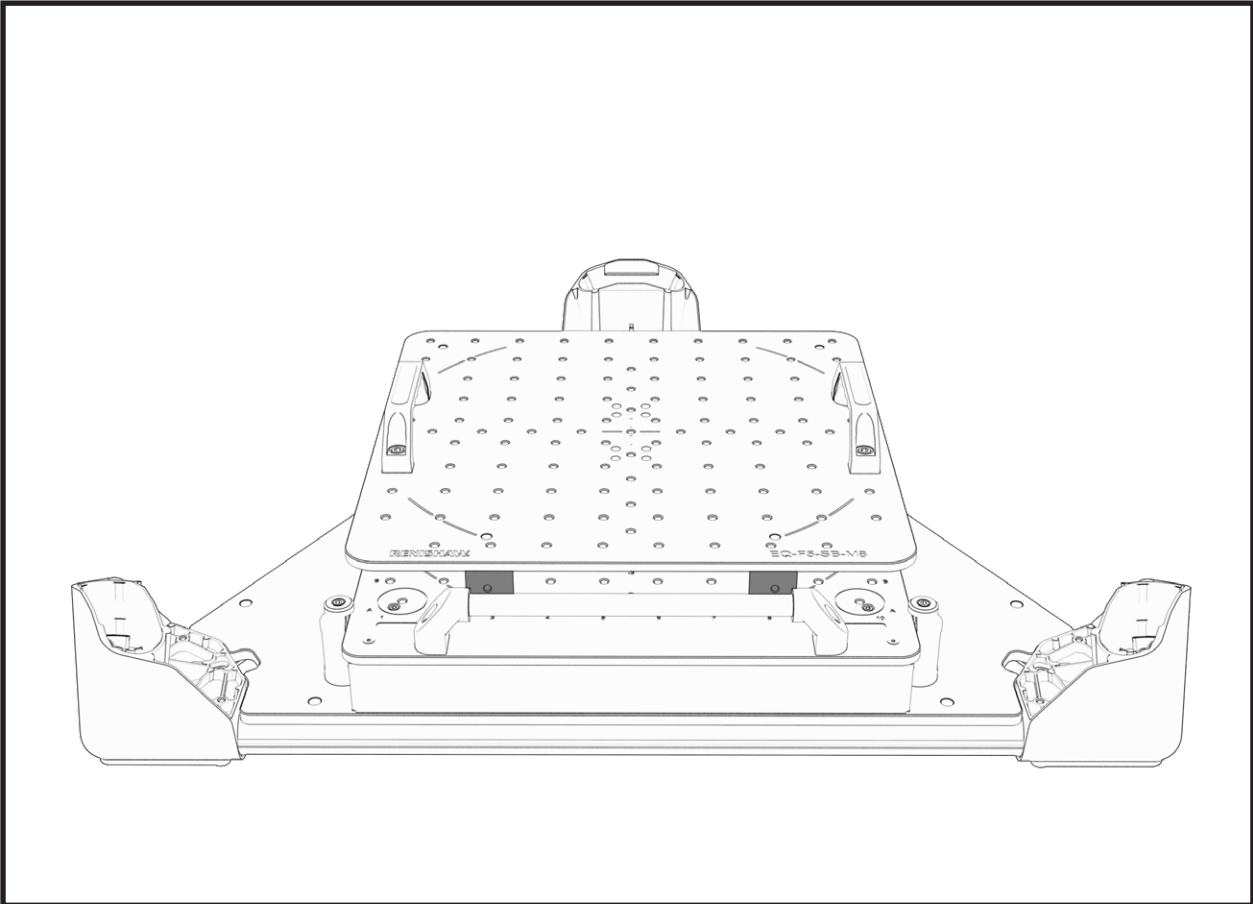
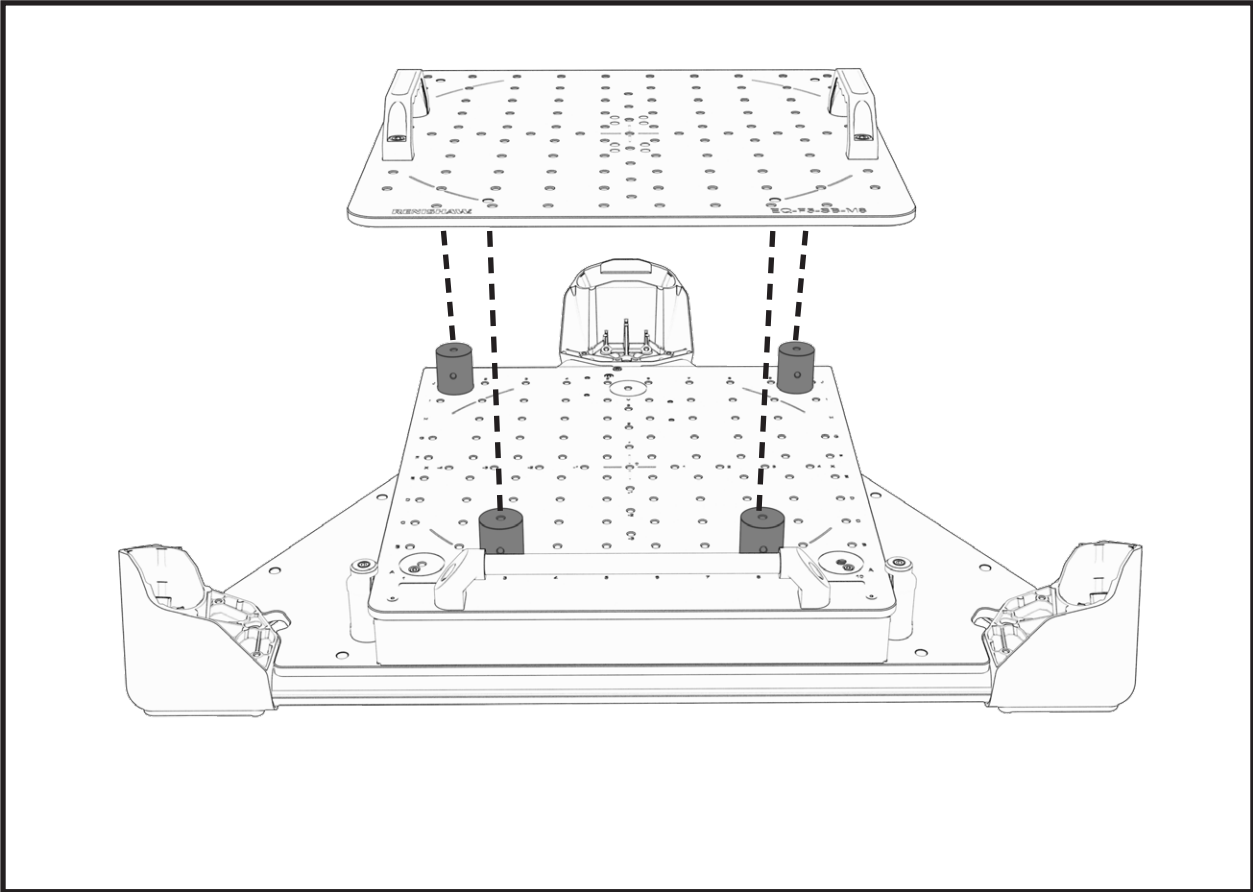

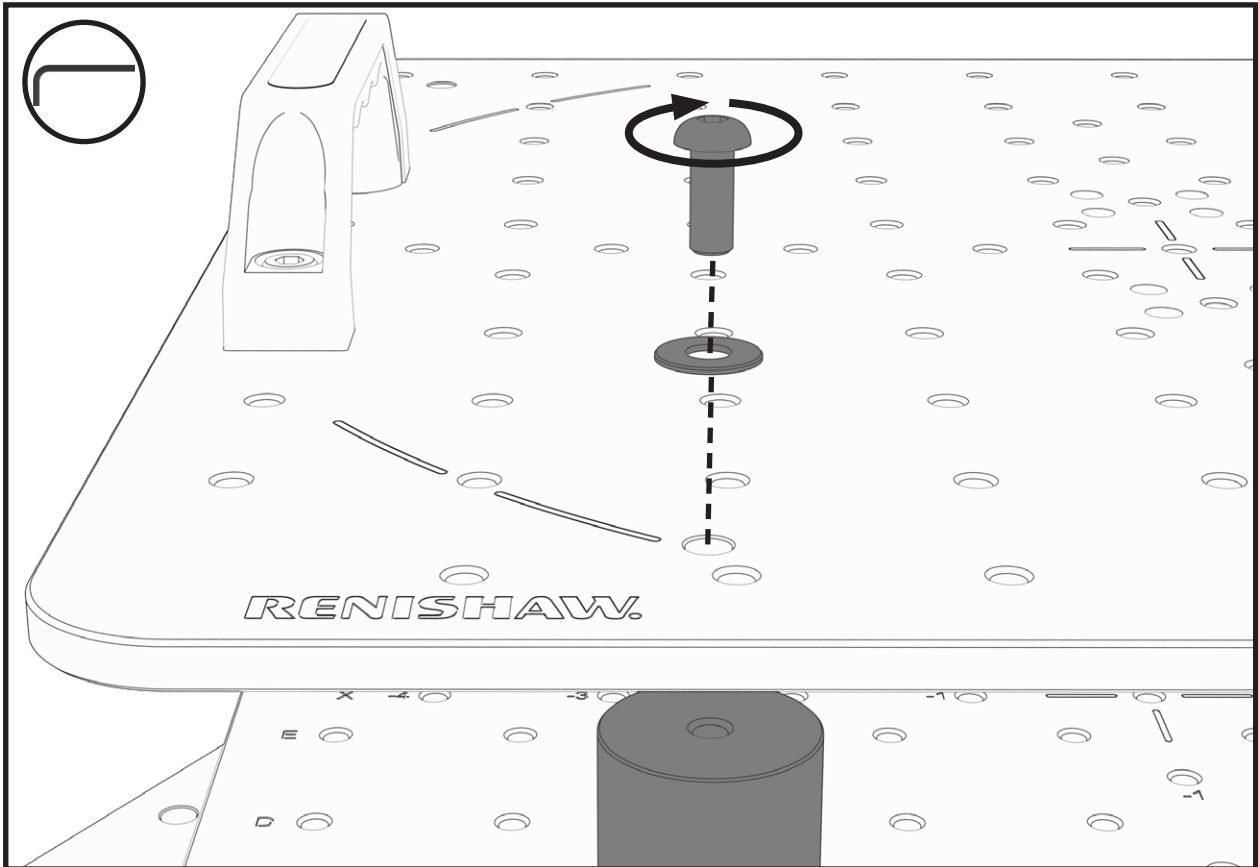

50 mm spacer configuration	
Available loading mass	17.3 kg
Tile height	23 mm below working volume

100 mm spacer

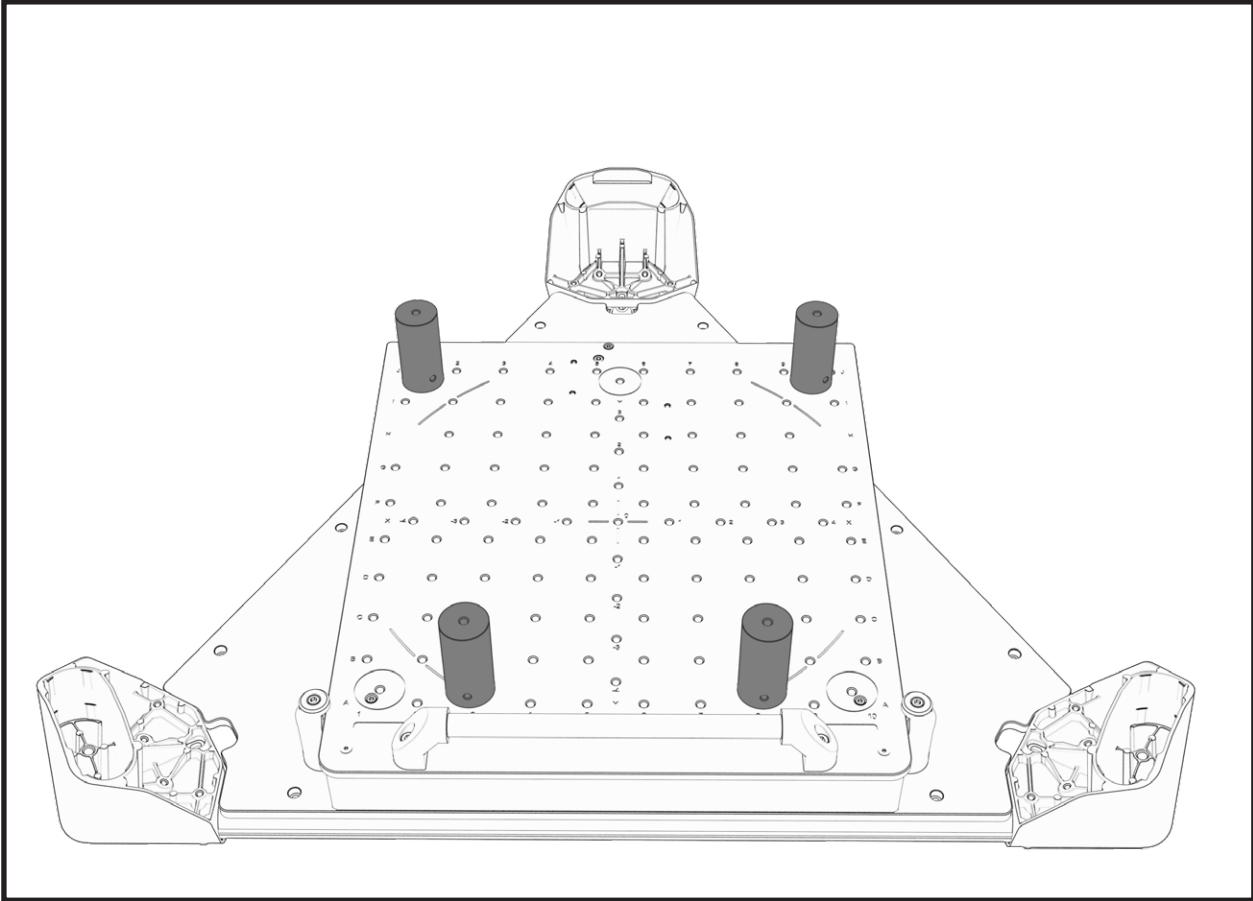
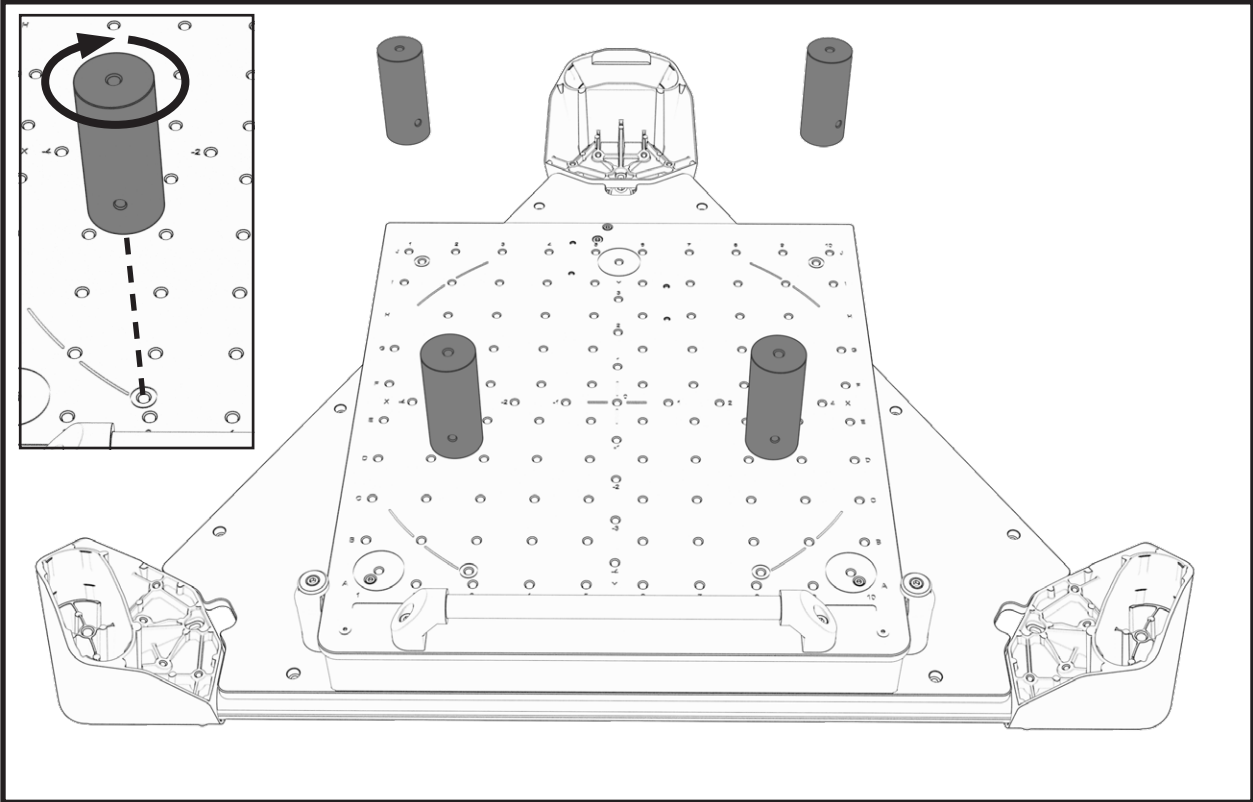

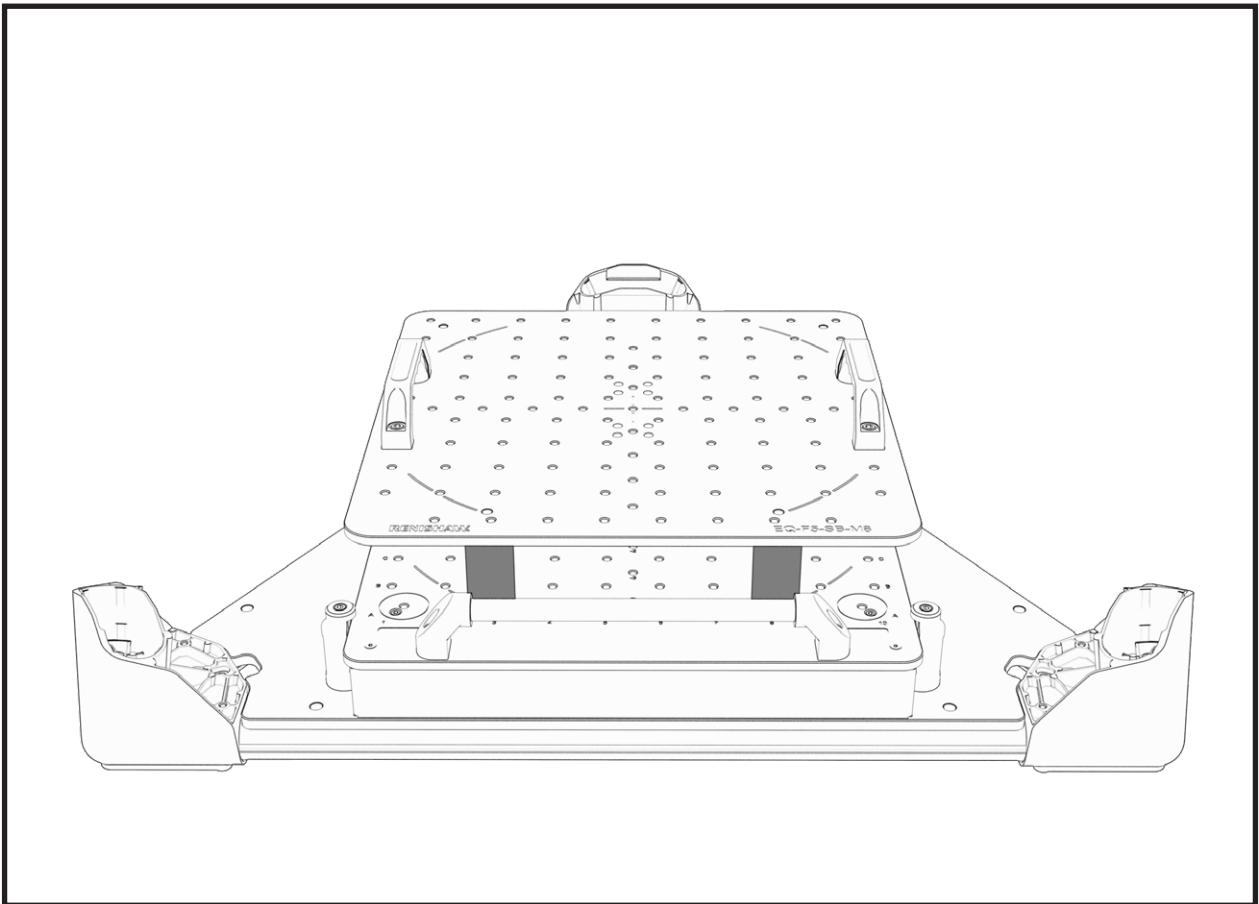
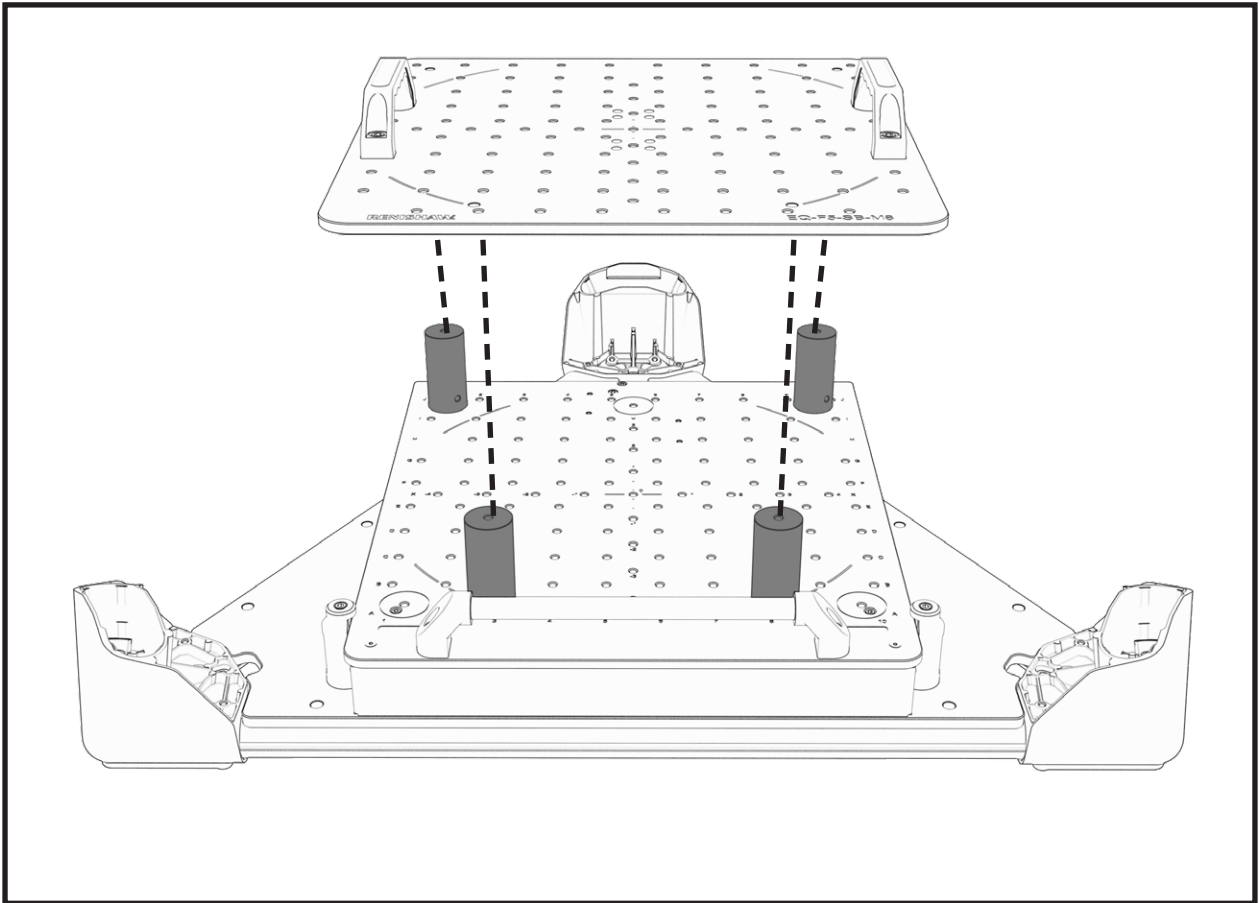

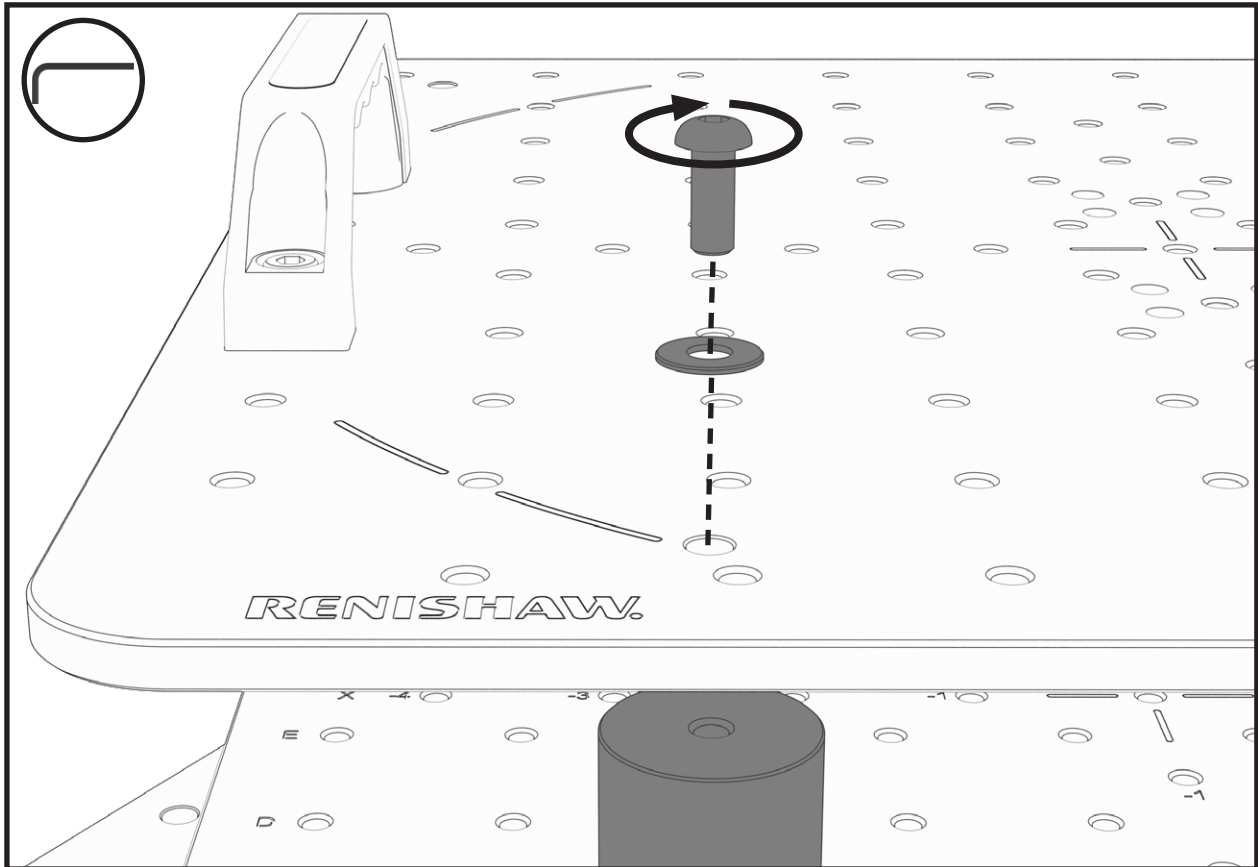

**100 mm spacer configuration**

<b>Available loading mass</b>	16.6 kg
<b>Tile height</b>	25.5 mm inside working volume

[www.renishaw.com/gauging](http://www.renishaw.com/gauging)



#renishaw

 +44 (0) 1453 524524

 [uk@renishaw.com](mailto:uk@renishaw.com)

© 2023 Renishaw plc. All rights reserved. This document may not be copied or reproduced in whole or in part, or transferred to any other media or language by any means, without the prior written permission of Renishaw.

RENISHAW® and the probe symbol are registered trade marks of Renishaw plc. Renishaw product names, designations and the mark 'apply innovation' are trade marks of Renishaw plc or its subsidiaries. Other brand, product or company names are trade marks of their respective owners.

WHILE CONSIDERABLE EFFORT WAS MADE TO VERIFY THE ACCURACY OF THIS DOCUMENT AT PUBLICATION, ALL WARRANTIES, CONDITIONS, REPRESENTATIONS AND LIABILITY, HOWSOEVER ARISING, ARE EXCLUDED TO THE EXTENT PERMITTED BY LAW. RENISHAW RESERVES THE RIGHT TO MAKE CHANGES TO THIS DOCUMENT AND TO THE EQUIPMENT, AND/OR SOFTWARE AND THE SPECIFICATION DESCRIBED HEREIN WITHOUT OBLIGATION TO PROVIDE NOTICE OF SUCH CHANGES.

Renishaw plc. Registered in England and Wales. Company no: 1106260. Registered office: New Mills, Wotton-under-Edge, Glos, GL12 8JR, UK.

Part no.: H-6620-8525-01-A

Issued: 12.2023