

EVOLUTE™, RTLA50 and FASTRACK™ absolute linear encoder system

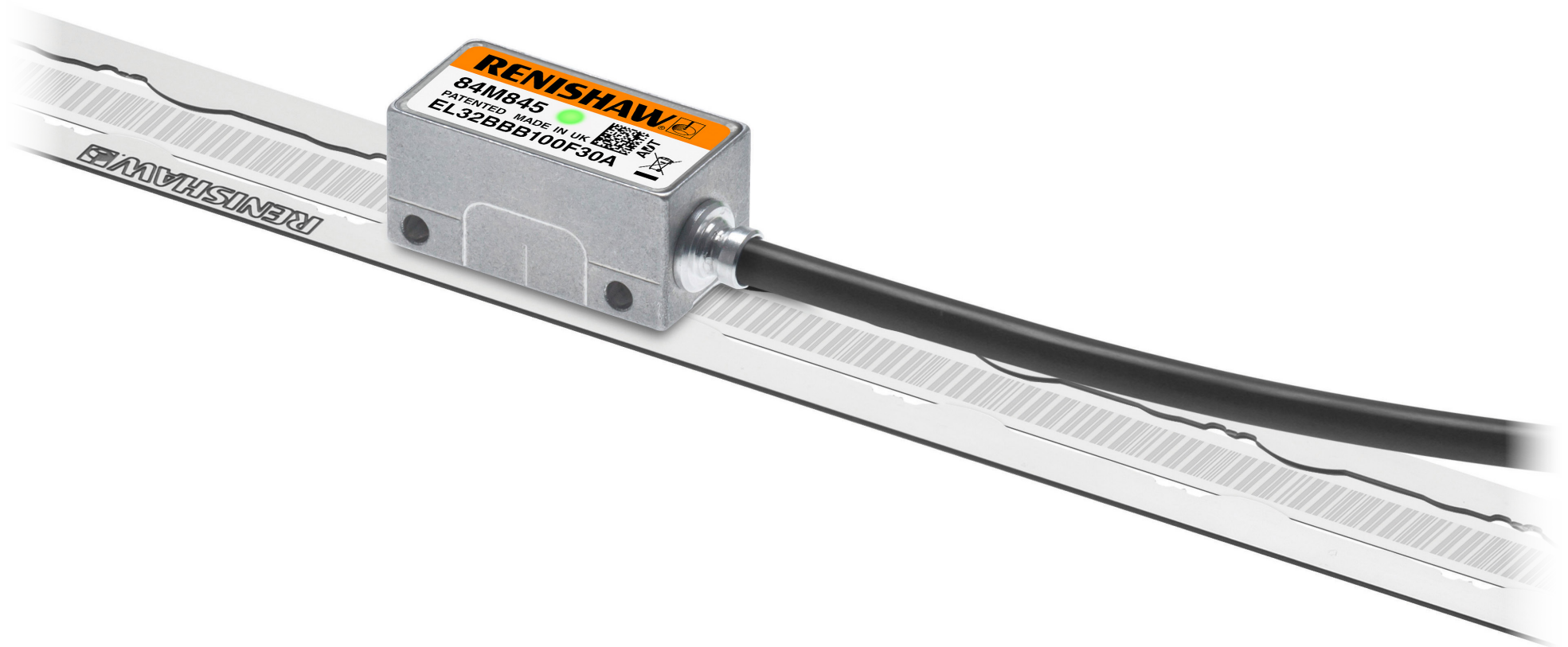

This page is intentionally left blank.

Contents

Legal notices4
Storage and handling7
EVOLUTE readhead installation drawing – standard cable outlet9
EVOLUTE readhead installation drawing – side cable outlet10
RTLA50/FASTRACK scale system installation drawing.11
Equipment required for installing the RTLA50 and FASTRACK scale system12
Cutting the RTLA50 scale and FASTRACK carrier.13
Applying the RTLA50 and FASTRACK scale system15
EVOLUTE readhead mounting and alignment18
EVOLUTE readhead signals19
EVOLUTE readhead termination options21
Siemens DRIVE-CLiQ interface drawing – single readhead input22
Electrical connections.23
General specifications24
RTLA50 scale and FASTRACK carrier specifications25

Legal notices

Patents

Features of Renishaw's EVOLUTE encoder systems and similar products are the subjects of the following patents and patent applications:

CN1260551	US7499827	JP4008356	GB2395005	CN1314511
EP1469969	JP5002559	CN102197282	EP2350570	JP2012507028
US20110173832	KR20110088506	CN102388295	EP2417423	KR20120014902
US2012007980	CN102460077	EP2438402	US20120072169	KR20120026579
US8141265	EP2294363	CN102057256	JP2011524534	KR20110033204

Terms and conditions and warranty

Unless you and Renishaw have agreed and signed a separate written agreement, the equipment and/or software are sold subject to the Renishaw Standard Terms and Conditions supplied with such equipment and/or software, or available on request from your local Renishaw office.

Renishaw warrants its equipment and software for a limited period (as set out in the Standard Terms and Conditions), provided that they are installed and used exactly as defined in associated Renishaw documentation. You should consult these Standard Terms and Conditions to find out the full details of your warranty.

Equipment and/or software purchased by you from a third-party supplier is subject to separate terms and conditions supplied with such equipment and/or software. You should contact your third-party supplier for details.

Declaration of Conformity

Renishaw plc hereby declares that the EVOLUTE encoder system is in compliance with the essential requirements and other relevant provisions of:

- the applicable EU directives
- the relevant statutory instruments under UK law



The full text of the declaration of conformity is available at: www.renishaw.com/productcompliance.

Compliance

Federal Code Of Regulation (CFR) FCC Part 15 – RADIO FREQUENCY DEVICES

47 CFR Section 15.19

This device complies with part 15 of the FCC Rules. Operation is subject to the following two conditions: (1) This device may not cause harmful interference, and (2) this device must accept any interference received, including interference that may cause undesired operation.

47 CFR Section 15.21

The user is cautioned that any changes or modifications not expressly approved by Renishaw plc or authorised representative could void the user's authority to operate the equipment.

47 CFR Section 15.105

This equipment has been tested and found to comply with the limits for a Class A digital device, pursuant to part 15 of the FCC Rules. These limits are designed to provide reasonable protection against harmful interference when the equipment is operated in a commercial environment.

This equipment generates, uses, and can radiate radio frequency energy and, if not installed and used in accordance with the instruction manual, may cause harmful interference to radio communications. Operation of this equipment in a residential area is likely to cause harmful interference in which case the user will be required to correct the interference at his own expense.

47 CFR Section 15.27

This unit was tested with shielded cables on the peripheral devices. Shielded cables must be used with the unit to ensure compliance.

Supplier's Declaration of Conformity

47 CFR § 2.1077 Compliance Information

Unique Identifier: EVOLUTE

Responsible Party - U.S. Contact Information

Renishaw Inc.
1001 Wesemann Drive
West Dundee
Illinois
IL 60118
United States
Telephone number: +1 847 286 9953
Email: usa@renishaw.com

ICES-003 – Information Technology Equipment (including Digital Apparatus)

This ISM device complies with Canadian ICES-003(A).

Cet appareil ISM est conforme à la norme ICES-003(A).

Intended use

The EVOLUTE encoder system is designed to measure position and provide that information to a drive or controller in applications requiring motion control. It must be installed, operated, and maintained as specified in Renishaw documentation and in accordance with the Standard Terms and Conditions of the Warranty and all other relevant legal requirements.

Further information

Further information relating to the EVOLUTE encoder range can be found in the following documents:

<i>EVOLUTE™ absolute optical encoder system</i> data sheet (Renishaw part no. L-9518-0027)
<i>ADTa-100 Advanced Diagnostic Tool</i> data sheet (Renishaw part no. L-9517-9834)
<i>Advanced Diagnostic Tools and ADT View software</i> user guide (Renishaw part no. M-6195-9413)

These can be downloaded from our website at www.renishaw.com/evolutedownloads and are also available from your local Renishaw representative.

Packaging

The packaging of our products contains the following materials and can be recycled.

Packing component	Material	ISO 11469	Recycling guidance
Outer box	Cardboard	Not applicable	Recyclable
	Polypropylene	PP	Recyclable
Inserts	Low density polyethylene foam	LDPE	Recyclable
	Cardboard	Not applicable	Recyclable
Bags	High density polyethylene bag	HDPE	Recyclable
	Metalised polyethylene	PE	Recyclable

REACH regulation

Information required by Article 33(1) of Regulation (EC) No. 1907/2006 ("REACH") relating to products containing substances of very high concern (SVHCs) is available at www.renishaw.com/REACH.

Disposal of waste electrical and electronic equipment



The use of this symbol on Renishaw products and/or accompanying documentation indicates that the product should not be mixed with general household waste upon disposal. It is the responsibility of the end user to dispose of this product at a designated collection point for waste electrical and electronic equipment (WEEE) to enable reuse or recycling. Correct disposal of this product will help to save valuable resources and prevent potential negative effects on the environment. For more information, contact your local waste disposal service or Renishaw distributor.

Storage and handling

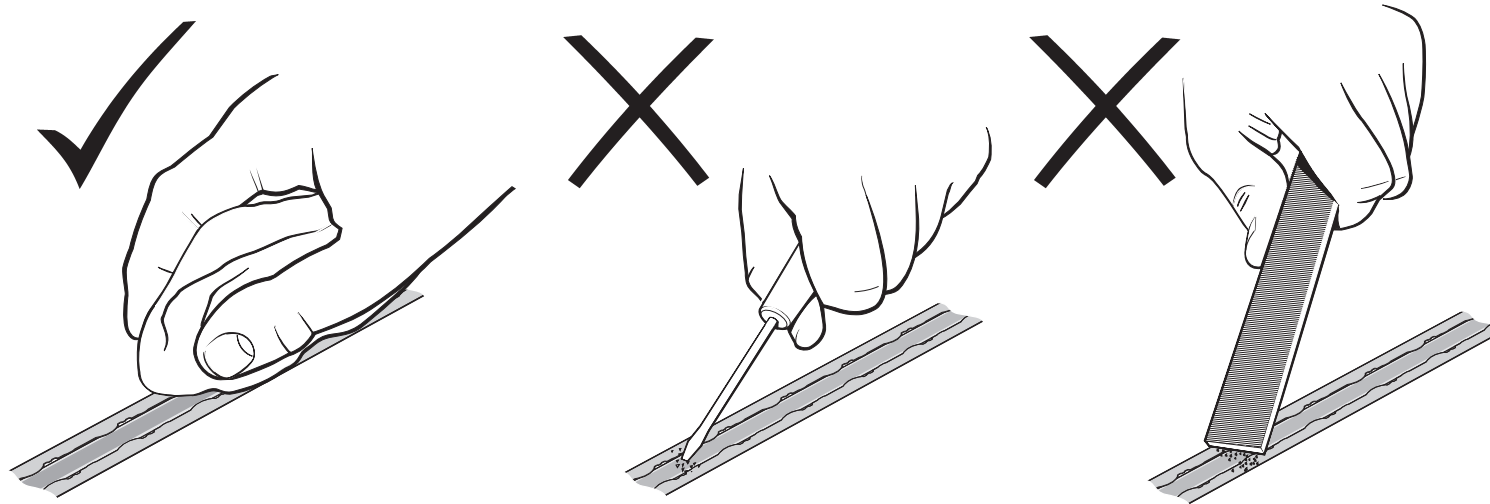

Minimum bend radius

RTLA50 scale - 50 mm
 FASTRACK™ carrier - 200 mm

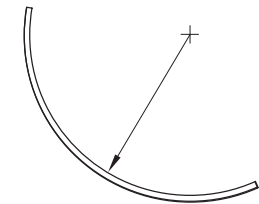

NOTE: During storage ensure the self-adhesive tape is on the outside of the bend.

System

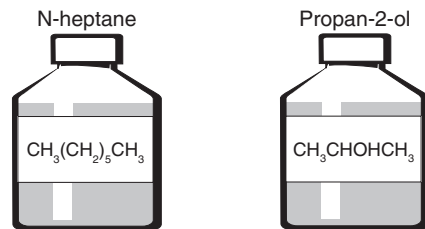

Readhead



Readhead and DRIVE-CLiQ interface

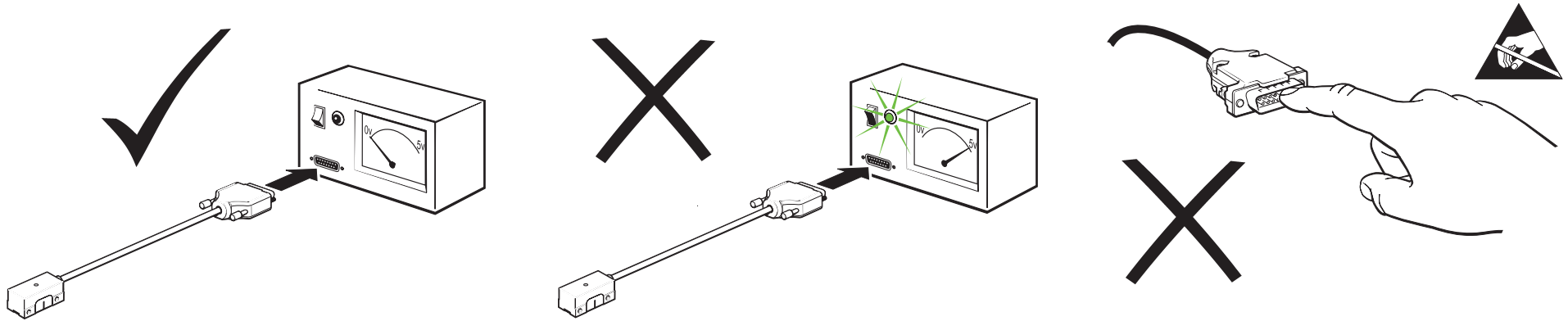

Temperature

Storage

EVOLUTE readhead, DRIVE-CLiQ interface, RTLA50 scale, and FASTRACK carrier	-20 °C to +80 °C
--	------------------

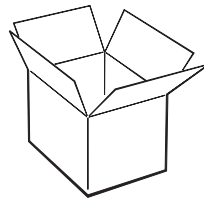

Operating

EVOLUTE readhead, RTLA50 scale, and FASTRACK carrier	0 °C to +80 °C
DRIVE-CLiQ interface	0 °C to +55 °C

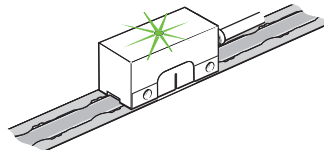

Humidity

95% relative humidity (non-condensing) to IEC 60068-2-78

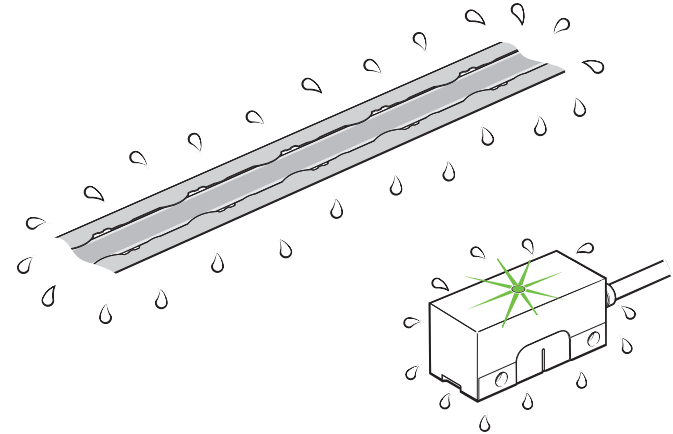

EVOLUTE readhead installation drawing – standard cable outlet

Dimensions and tolerances in mm

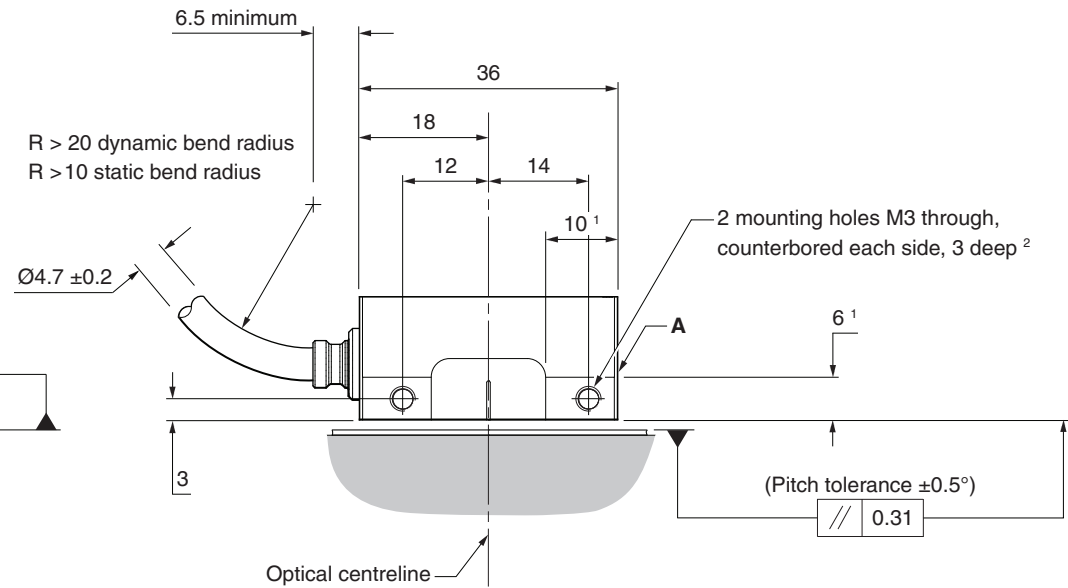
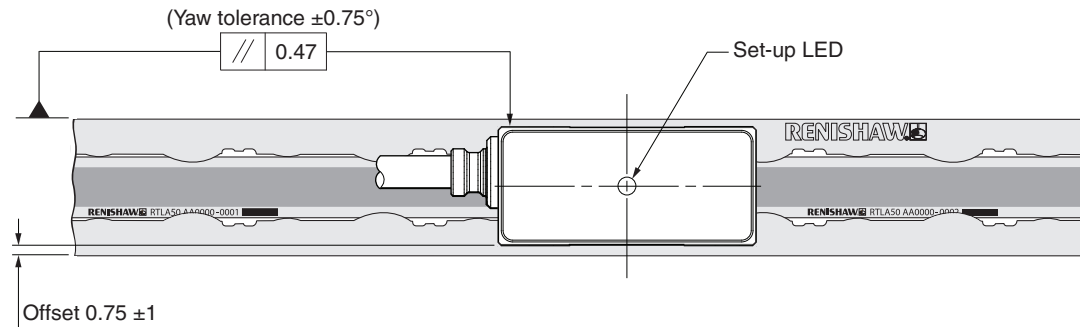
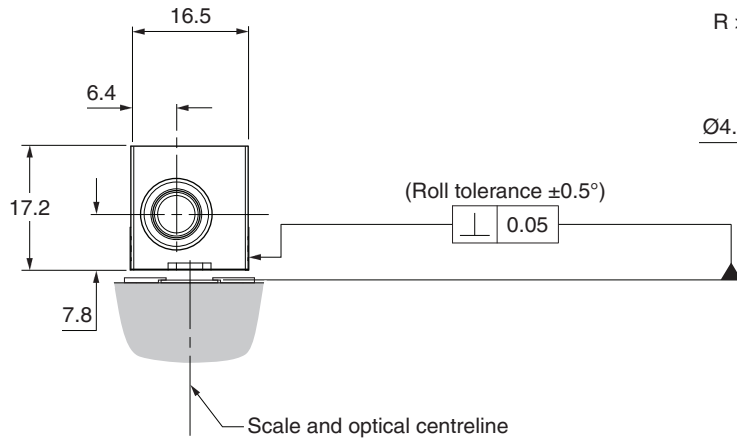
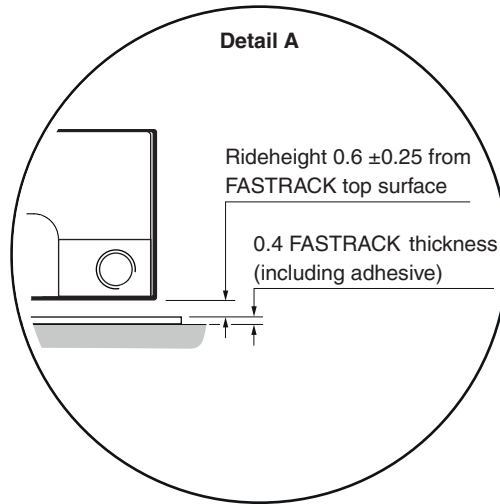

¹ Extent of mounting faces.

² The recommended thread engagement is 5 mm minimum (8 mm including counterbore) and the recommended tightening torque is 0.5 Nm to 0.7 Nm.

EVOLUTE readhead installation drawing – side cable outlet

Dimensions and tolerances in mm

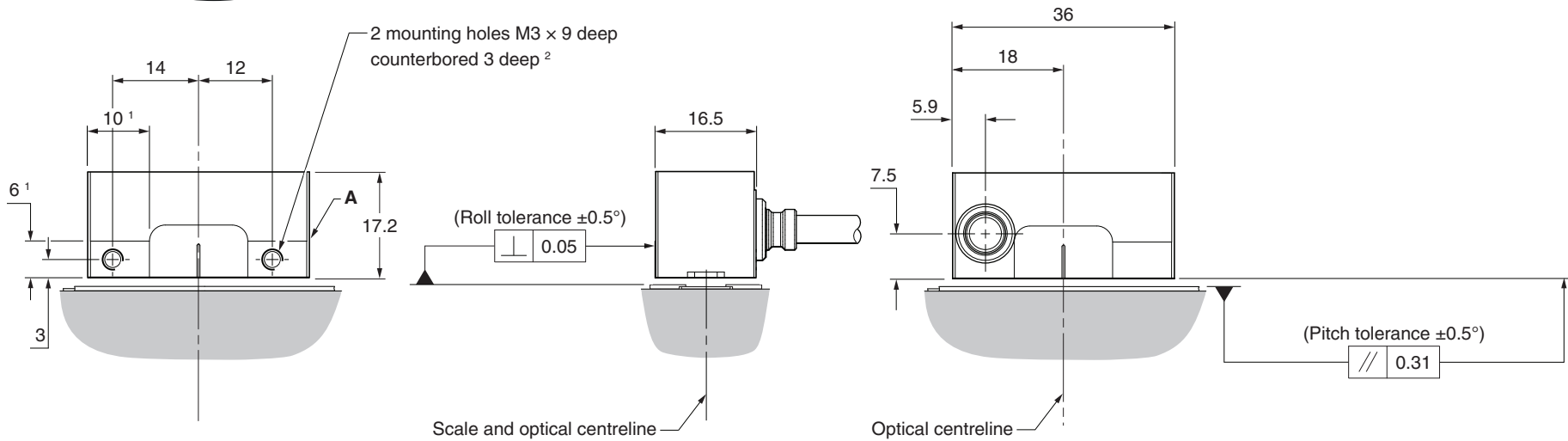
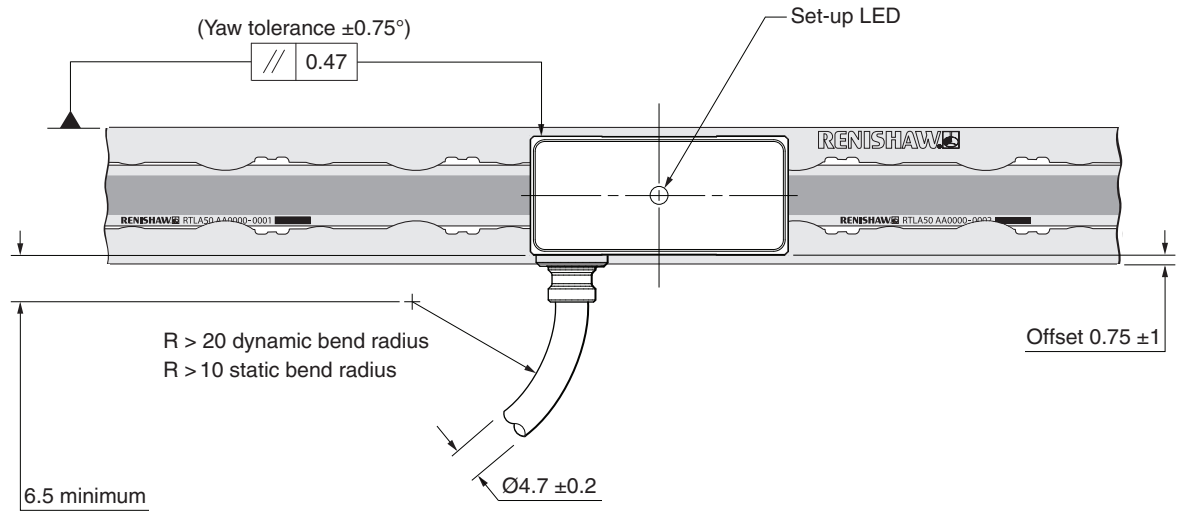
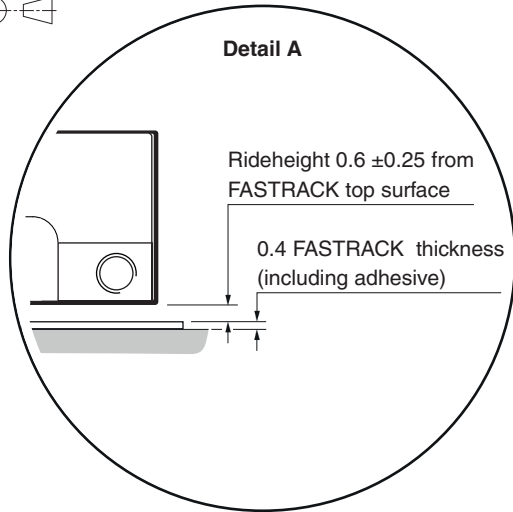

¹ Extent of mounting faces.

² The recommended thread engagement is 5 mm minimum (8 mm including counterbore) and the recommended tightening torque is 0.5 Nm to 0.7 Nm.

RTLA50/FASTRACK scale system installation drawing

Dimensions and tolerances in mm ¹

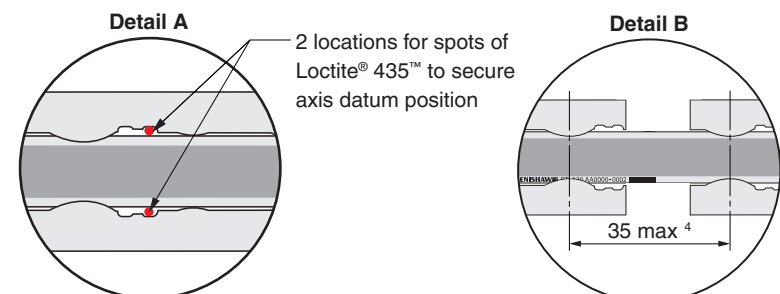
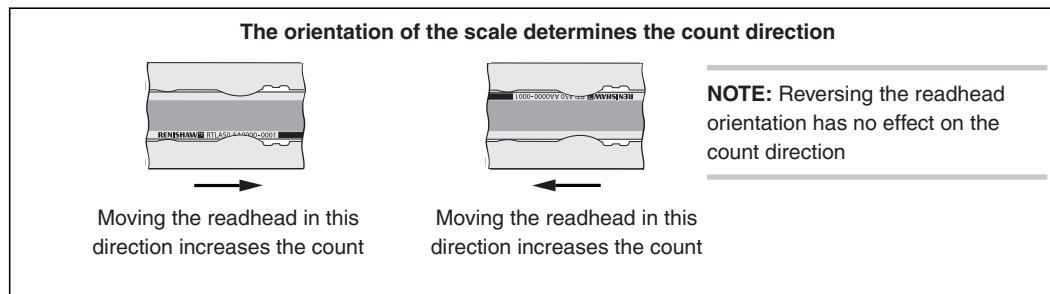
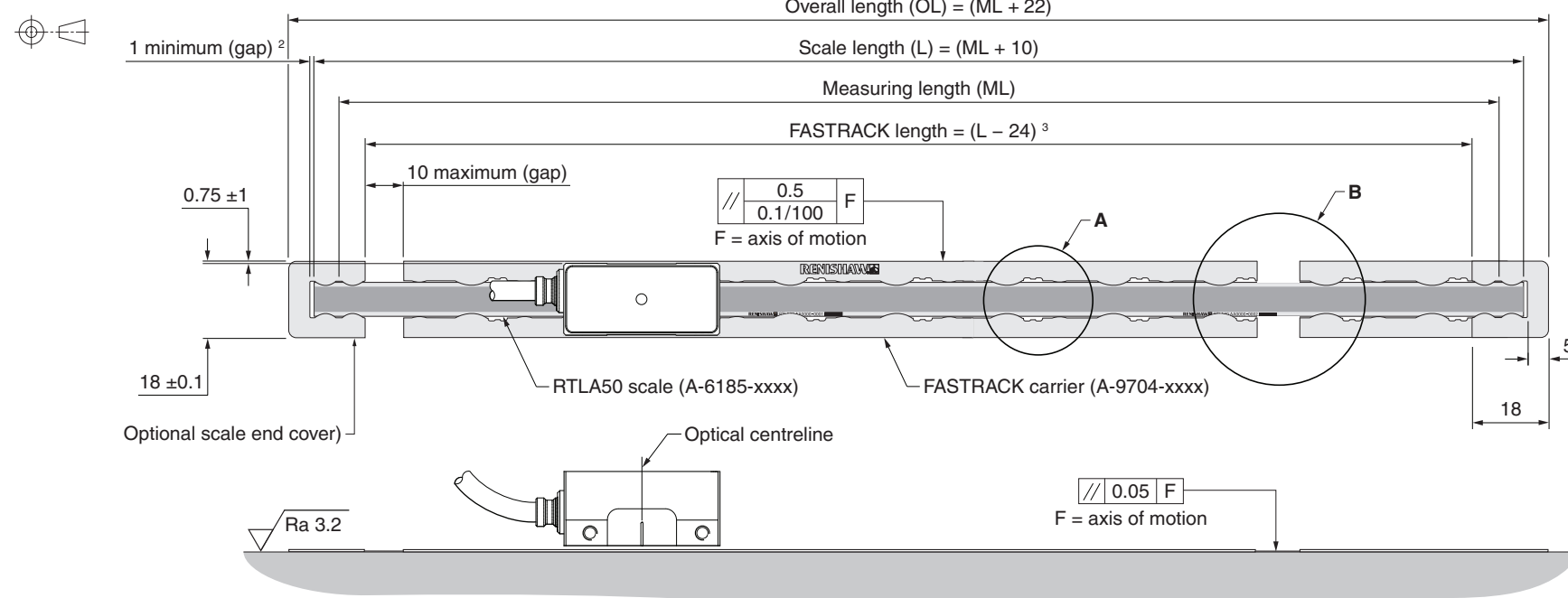

¹ All dimensions applicable when using side cable outlet version.

² For thermal expansion.

³ Assumes 1 mm gap between the scale and the end covers and zero gap between the FASTRACK carrier and the end covers. The minimum recommended FASTRACK carrier length = 100 mm.

⁴ Only required for sectional installations.

Equipment required for installing the RTLA50 and FASTRACK scale system

Required parts:

- Appropriate length of RTLA50 scale (see 'RTLA50/FASTRACK scale system installation drawing' on page 11)
- Appropriate length of FASTRACK carrier ¹ (see 'RTLA50/FASTRACK scale system installation drawing' on page 11)
- Loctite® 435™ (P-AD03-0012)
- Lint-free cloth
- Appropriate cleaning solvents (see 'Storage and handling' on page 7)
- Centre section removal tool (A-9589-0122)
- Small pair of pliers
- Dial test indicator (DTi)
- Protective gloves

Optional parts:

- A pair of scale end covers (A-9589-0058)
- Renishaw scale wipes (A-9523-4040)
- Loctite® 435™ dispensing tip (P-TL50-0209)
- RTL scale installation tool (A-9589-0420)
- Guillotine (A-9589-0071) or shears (A-9589-0133) for cutting RTLA50 scale and FASTRACK carrier to length required

¹ Minimum recommended length of FASTRACK is 100 mm.

Cutting the RTLA50 scale and FASTRACK carrier

CAUTION: During handling or installation of FASTRACK, suitable gloves should be worn to protect against injury from sharp edges.

If required cut the FASTRACK carrier and RTLA50 scale to length (separately) using the guillotine or the shears after referring to the 'RTLA50/FASTRACK scale system installation drawing' on page 11.

Using the guillotine

The guillotine should be held securely in place, using a suitable vice or clamping method.

Once secured, feed the FASTRACK or the scale through the guillotine as shown, and place the guillotine press block down onto the FASTRACK/scale.

NOTE: Ensure the block is in the correct orientation (as shown below).

Whilst holding the block in place, in a smooth motion, pull down the lever to cut through the FASTRACK/scale.

Guillotine press block orientation when cutting the FASTRACK carrier

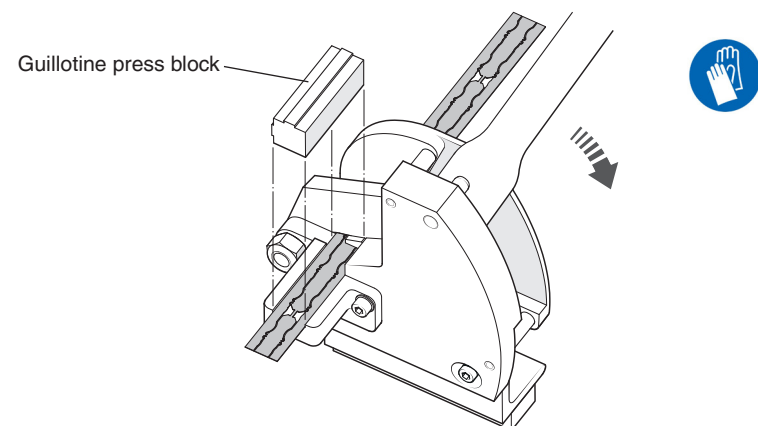

Guillotine press block orientation when cutting the RTLA50 scale

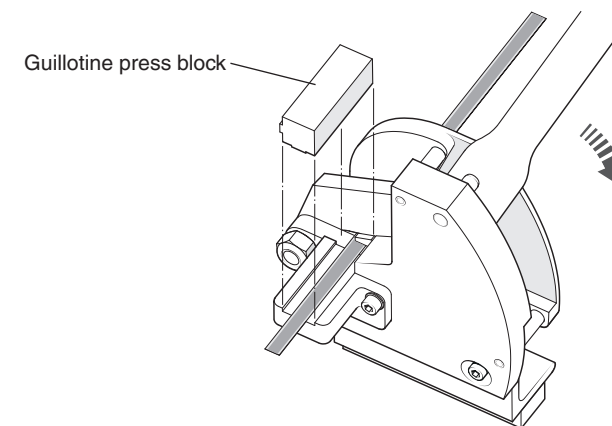

CAUTION: Do not cut the FASTRACK in these areas

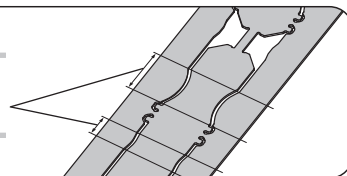

Using the shears

Feed the FASTRACK carrier or RTLA50 scale through the appropriately sized aperture on the shears (as shown below).

Hold the scale in place and close the shears in a smooth motion to cut through the scale.

Insertion of the FASTRACK carrier through widest aperture

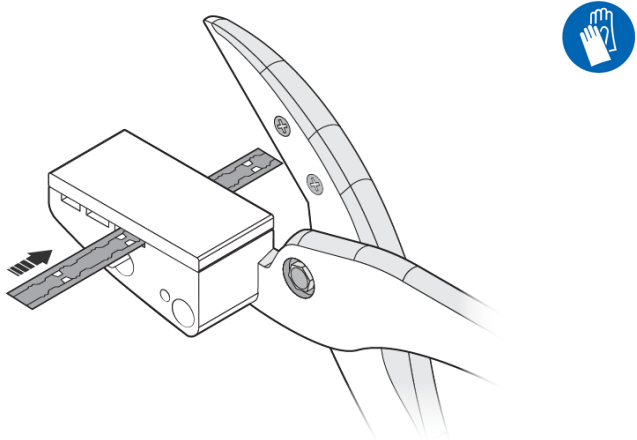

Insertion of the RTLA50 scale through the middle aperture

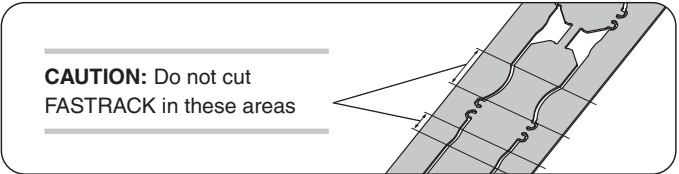
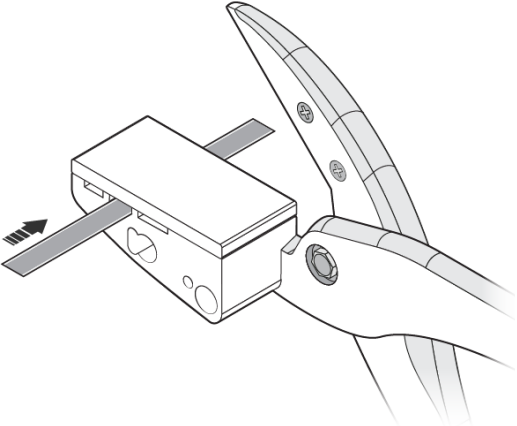

Applying the RTLA50 and FASTRACK scale system

1. Thoroughly clean and degrease the substrate and allow to dry.

For FASTRACK location a ledge, separate straight edge(s) or dowels can be used.

Check alignment of the ledge/separate straight edge(s) with respect to axis of motion (see 'RTLA50/FASTRACK scale system installation drawing' on page 11).

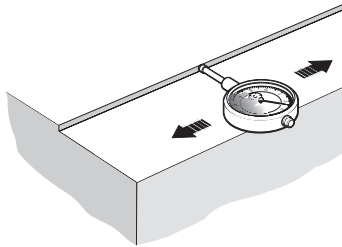

2. Before sticking the FASTRACK to the substrate bend the centre section upwards slightly using a small pair of pliers.

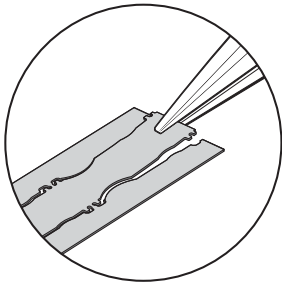

3. Remove the backing liner and stick the FASTRACK to the substrate locating it against the ledge/separate straight edge(s) or dowels.

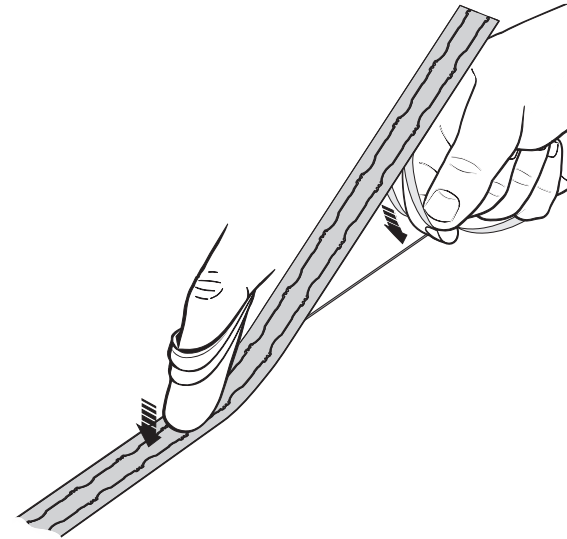

Ensure complete adhesion to the substrate by applying firm finger pressure along the length of the FASTRACK from the centre outwards towards each end using a lint-free cloth.

NOTE: Allow the FASTRACK a minimum of 20 minutes to adhere before removing the centre section.

- Engage the centre section removal tool and, with consistent forward pressure, remove the centre section of the FASTRACK carrier.

If the ledge method or similar is used then the appropriate side panel on the removal tool will need to be removed as shown below.

IMPORTANT: Wear suitable protective gloves whilst carrying out this procedure to avoid the risk of cuts.

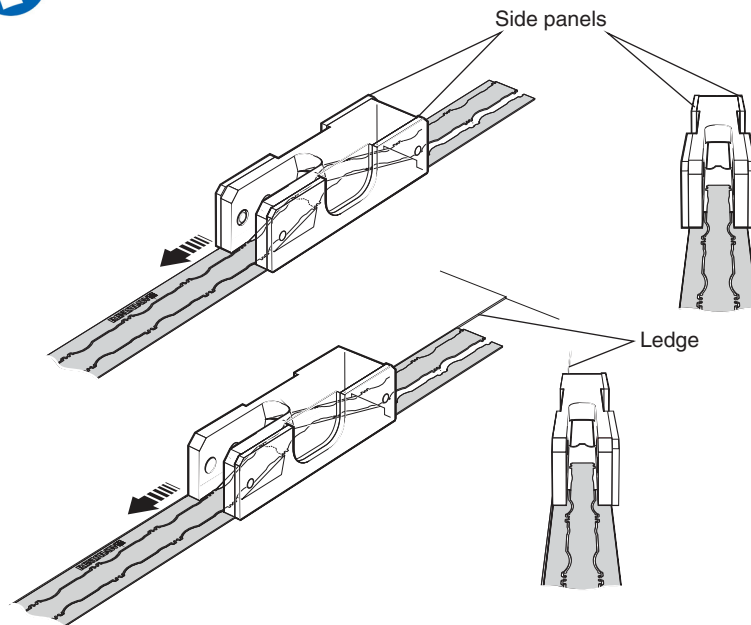

- Slide the RTLA50 scale into the FASTRACK ensuring the scale is fed under the projections as shown below.

The RTLA50 scale can be installed manually by either pulling or pushing it through the FASTRACK carrier.

Alternatively, use the optional RTL scale installation tool as shown below.

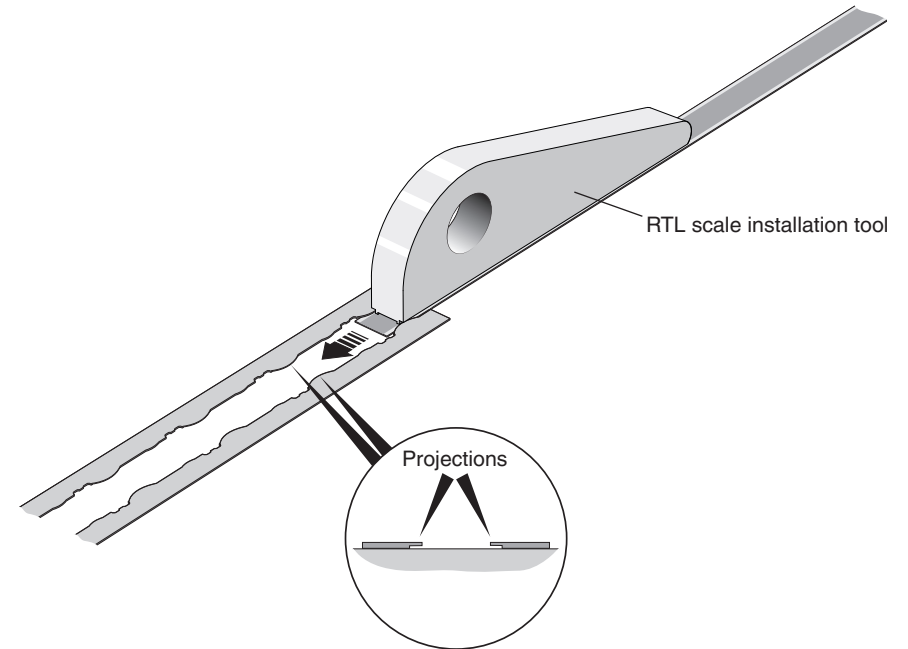

NOTE: For instructions on how to use the scale installation tool, download the *RTL* scale installation tool* user guide (Renishaw part no. M-9589-9101) from the website at www.renishaw.com/evolutedownloads.

IMPORTANT: If manually installing the scale using fingers, suitable gloves should be worn to protect against injury from sharp edges.



6. Create a scale datum. Using dispensing tip apply Loctite 435 between scale and FASTRACK so it wicks underneath the scale and FASTRACK adjacent to the user selected datum location as shown below.

NOTE: Only apply Loctite 435 in the locations shown below. Loctite 435 has been carefully selected as it will wick under the scale to lock it to the substrate. Dispensing tips are available.

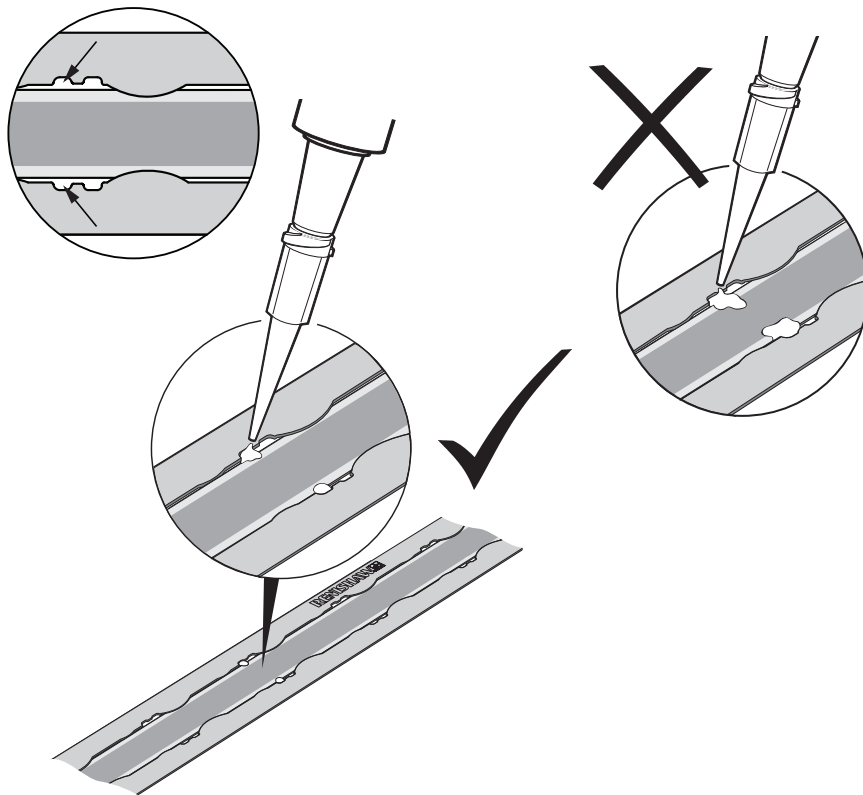

NOTE: Mechanical datum clamp also available. Contact your local Renishaw representative for more details.

7. Optional: Fix the self-adhesive end covers ensuring a gap of at least 1 mm.

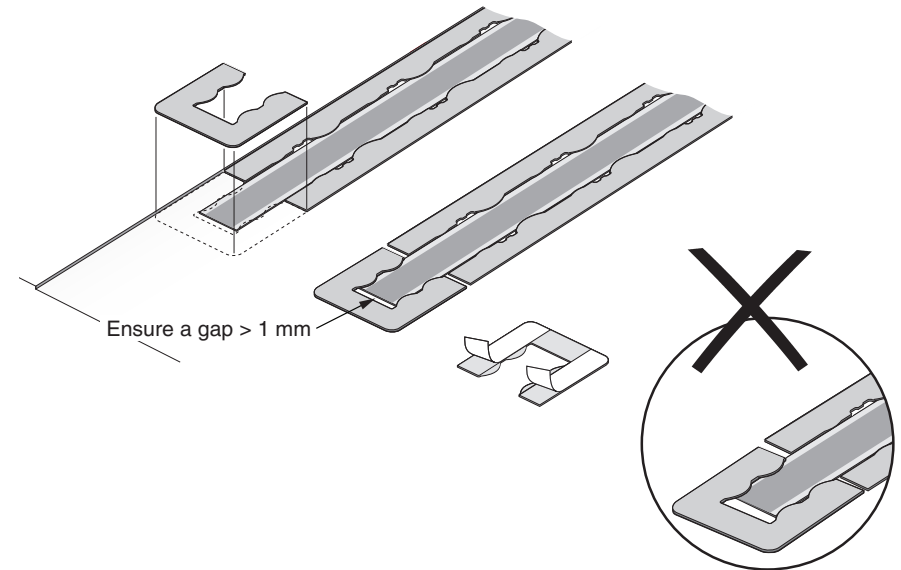

8. Clean the FASTRACK and the scale using a lint-free cloth.

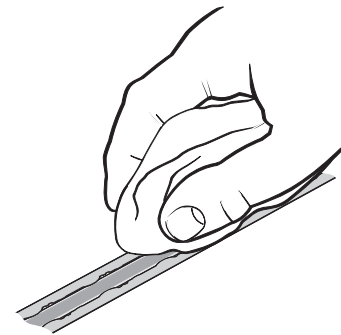

EVOLUTE readhead mounting and alignment

Mounting brackets

The bracket must have a flat mounting surface and should provide adjustment to enable conformance to the installation tolerances, allow adjustment to the rideheight of the readhead, and be sufficiently stiff to prevent deflection or vibration of the readhead during operation.

Readhead set-up

Ensure that the scale, readhead optical window and mounting face are clean and free from obstructions.

NOTE: When cleaning the readhead and scale apply cleaning fluid sparingly, do not soak.

To set nominal rideheight, place the red spacer with the aperture under the optical centre of the readhead to allow normal LED function during set-up procedure. Adjust the readhead to maximize the signal strength along the full axis of travel to achieve a green LED.

NOTES:

- A position error will trigger the set-up LED to flash continuously until the error is no longer present AND:
 - Power has been cycled OR
 - A position request has been received from the controller
- The optional Advanced Diagnostic Tool ADTa-100 ¹ (A-6525-0100) and ADT View software ² can be used to aid installation.

¹ For more details refer to the *Advanced Diagnostic Tools and ADT View software* user guide (Renishaw part no. M-6195-9413).

² The software can be downloaded for free from www.renishaw.com/adt.

³ The LED is activated regardless of whether the corresponding messages have been reconfigured.

⁴ The colour depends upon the LED status when component recognition is activated via p0144=1.

⁵ EVOLUTE Siemens DRIVE-CLiQ readheads require the Siemens DRIVE-CLiQ interface to function correctly.

EVOLUTE readhead and DRIVE-CLiQ interface status LEDs

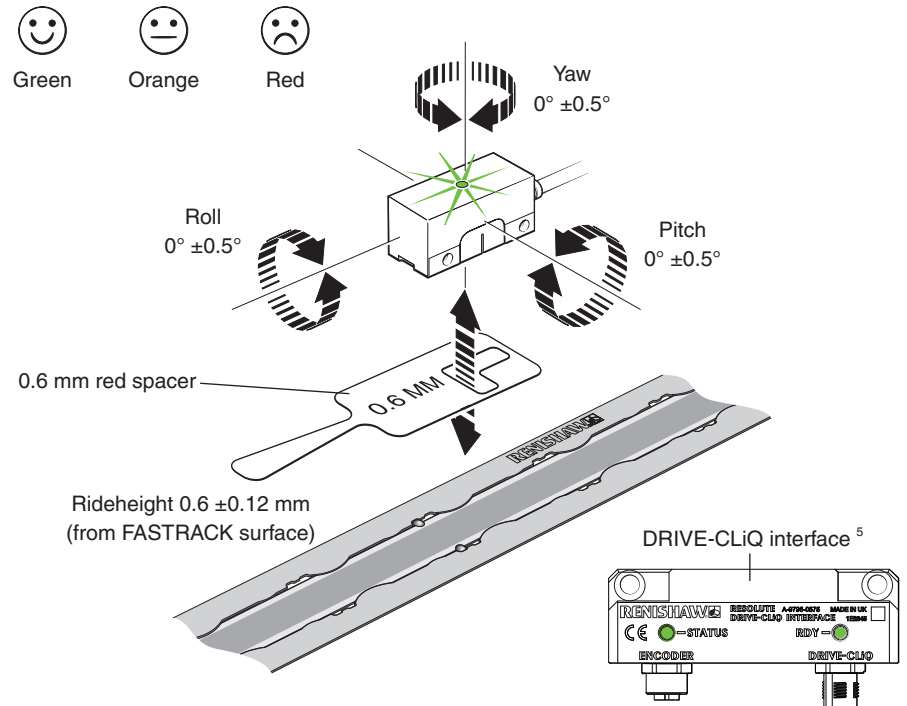

DRIVE-CLiQ interface RDY LED functions

Colour	Status	Description
-	Off	Power supply is missing or outside of permissible tolerance range
Green	Continuous light	The component is ready for operation and cyclic DRIVE-CLiQ communication is taking place
Orange	Continuous light	DRIVE-CLiQ communication is being established
Red	Continuous light	At least one fault is present in this component ³
Green/orange or red/orange	Flashing light	Component recognition via LED is activated (p0144) ⁴

EVOLUTE readhead signals

BiSS C serial interface

Function	Signal ¹	Wire colour	Pin
			9-way D-type (A)
Power	5 V	Brown	4, 5
	0 V	White	8, 9
		Green	
Serial communications	MA+	Violet	2
	MA-	Yellow	3
	SLO+	Grey	6
	SLO-	Pink	7
Shield	Shield	Shield	Case

Mitsubishi serial interface

Function	Signal	Wire colour	Pin
			9-way D-type (A)
Power	5 V	Brown	4, 5
	0 V	White	8, 9
		Green	
Serial communications	MR	Violet	2
	MRR	Yellow	3
Shield	Shield	Shield	Case
Reserved	Do not connect	Grey	6
		Pink	7

FANUC serial interface

Function	Signal	Wire colour	Pin
			9-way D-type (A)
Power	5 V	Brown	4, 5
	0 V	White	8, 9
		Green	
Serial communications	REQ	Violet	2
	*REQ	Yellow	3
	SD	Grey	6
	*SD	Pink	7
Shield	Shield	Shield	Case

Panasonic serial interface

Function	Signal	Wire colour	Pin
			9-way D-type (A)
Power	5 V	Brown	4, 5
	0 V	White	8, 9
		Green	
Serial communications	PS	Violet	2
	\overline{PS}	Yellow	3
Shield	Shield	Shield	Case
Reserved	Do not connect	Grey	6
		Pink	7

¹ For details, refer to *BiSS C-mode (unidirectional) for EVOLUTE™ encoders* data sheet (Renishaw part no. L-9517-9665).

Siemens DRIVE-CLiQ serial interface

DRIVE-CLiQ readhead output

Function	Signal	Wire colour	Pin
			M12 (S)
Power	5 V	Brown	2
	0 V	White	5, 8
Green			
Serial communications	A+	Violet	3
	A-	Yellow	4
Shield	Shield	Shield	Case
Reserved	Do not connect	Grey	7
		Pink	6

DRIVE-CLiQ interface output

Function	Signal	Pin
		M12
Power	24 V	1
	0 V	5
DRIVE-CLiQ communications	RX+	3
	RX-	4
	TX+	7
	TX-	6
Shield	Shield	Case

Yaskawa serial interface

Function	Signal	Wire colour	Pin
			9-way D-type (A)
Power	5 V	Brown	4, 5
	0 V	White	8, 9
Green			
Serial communications	S	Violet	2
	\bar{S}	Yellow	3
Shield	Shield	Shield	Case
Reserved	Do not connect	Grey	6
		Pink	7

EVOLUTE readhead termination options

9-way D-type connector (Termination code A)

BiSS C (unidirectional), FANUC, Mitsubishi, Panasonic and Yaskawa systems only

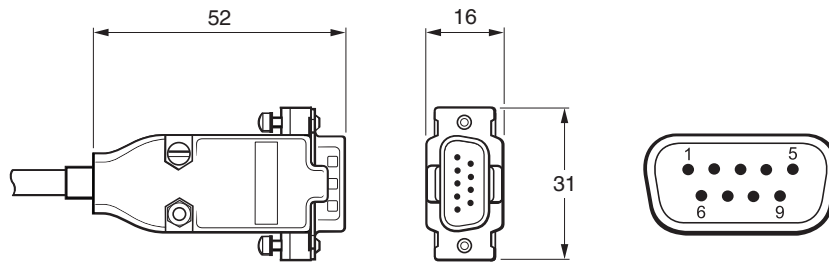

M12 (sealed) connector (Termination code S)

Siemens DRIVE-CLiQ systems only

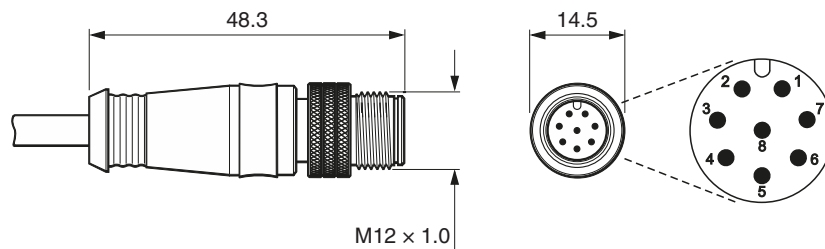

Siemens DRIVE-CLiQ interface drawing – single readhead input

Dimensions and tolerances in mm

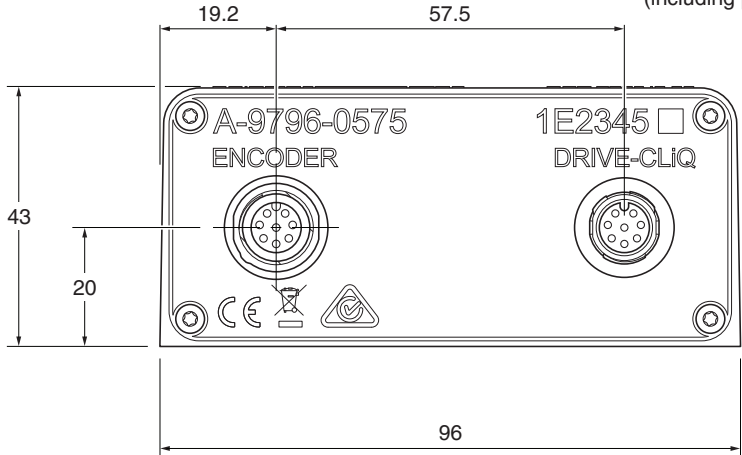
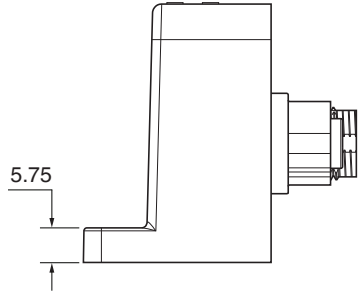
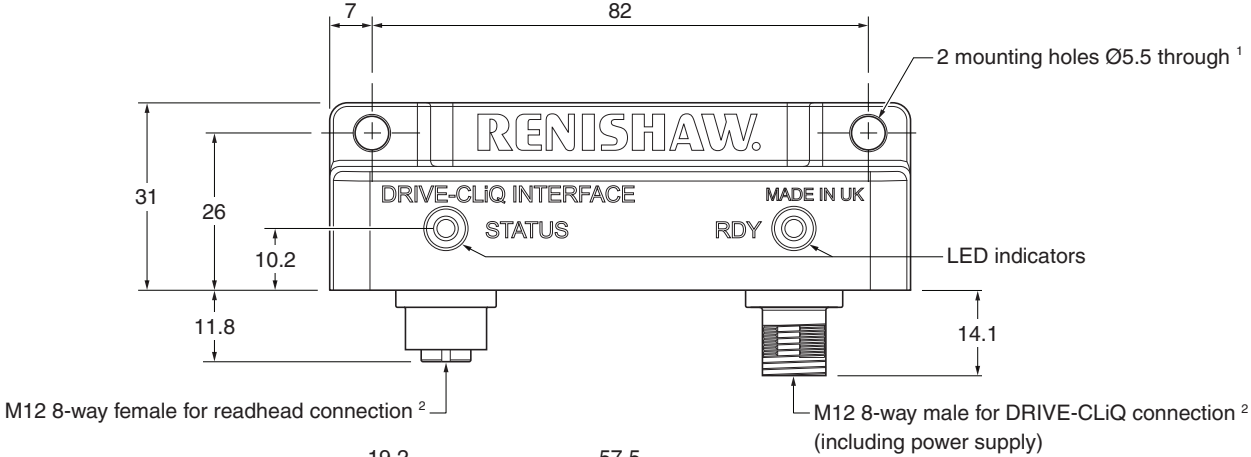

Interface part number	Compatible readheads
A-9796-0575	EL28D*

NOTE: EVOLUTE Siemens DRIVE-CLiQ readheads require the Siemens DRIVE-CLiQ interface to function correctly.

¹ Screw grade: ISO 4762-M5. Maximum tightening torque 4 Nm. Recommended thread engagement ≥ 5 mm.

² Maximum tightening torque 4 Nm.

Electrical connections

Grounding and shielding – EVOLUTE BiSS C (unidirectional), FANUC, Mitsubishi, Panasonic and Yaskawa systems

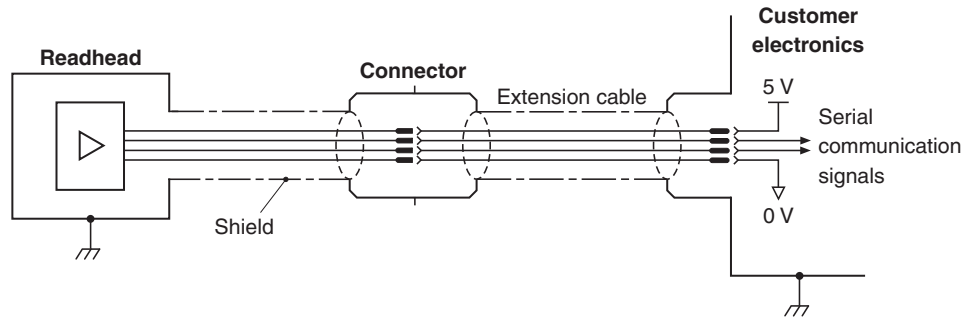

IMPORTANT:

- The shield should be connected to the machine earth (Field ground).
- If the connector is modified or replaced, the customer must ensure both 0 V cores (white and green) are connected to 0 V.

Grounding and shielding – EVOLUTE Siemens DRIVE-CLiQ systems only

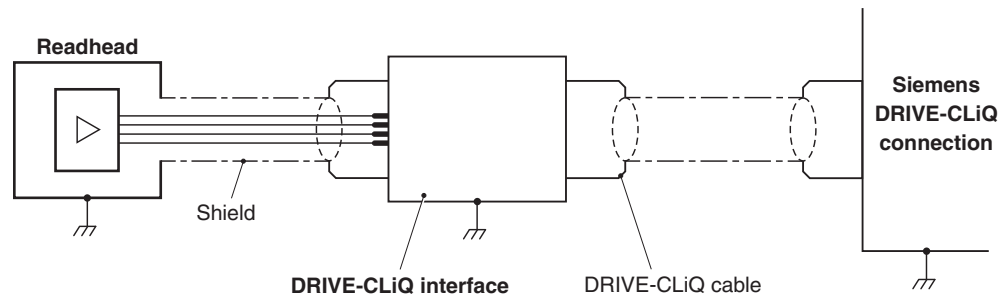

General specifications

Power supply ¹	5 V ±10%	1.25 W maximum (250 mA @ 5 V)
	24 V (DRIVE-CLiQ system only) ²	1.8 W maximum (75mA @ 24 V). 24 V as per DRIVE-CLiQ specification. 24 V power is provided by the DRIVE-CLiQ network.
	Ripple	200 mVpp maximum @ frequency up to 500 kHz
Sealing	Readhead	IP64
	DRIVE-CLiQ interface	IP67
Acceleration	Readhead (operating)	500 m/s ² , 3 axes
Shock	Readhead and DRIVE-CLiQ interface (non-operating)	1000 m/s ² , 6 ms, ½ sine, 3 axes
Maximum acceleration of scale with respect to readhead ³		2000 m/s ²
Vibration	Readhead (operating)	Sinusoidal 300 m/s ² , 55 Hz to 2000 Hz, 3 axes
	DRIVE-CLiQ interface (operating)	Sinusoidal 100 m/s ² , 55 Hz to 2000 Hz, 3 axes
Mass	Readhead	18 g
	Cable	32 g/m
	DRIVE-CLiQ interface	218 g
Readhead cable		7 core, tinned and annealed copper, 28 AWG Outside diameter 4.7 ±0.2 mm Flex life > 40 × 10 ⁶ cycles at 20 mm bend radius UL recognised component 
Maximum readhead cable length ⁴		3 m (to controller or DRIVE-CLiQ interface) (Refer to Siemens DRIVE-CLiQ specifications for maximum cable length from DRIVE-CLiQ interface to controller)

CAUTION: The EVOLUTE encoder system has been designed to the relevant EMC standards, but must be correctly integrated to achieve EMC compliance. In particular, attention to shielding arrangements is essential.

¹ Current consumption figures refer to terminated EVOLUTE systems. Renishaw encoder systems must be powered from a 5 Vdc supply complying with the requirements for SELV of standard IEC 60950-1.

² The Renishaw DRIVE-CLiQ interface must be powered from a 24 Vdc supply complying with the requirements for SELV of standard IEC 60950-1.

³ This is the worst case figure that is correct for the slowest communications clock rates. For faster clock rates, the maximum acceleration of scale with respect to the readhead can be higher. For more details, contact your local Renishaw representative.

⁴ Extension cables are available. For more details, contact your local Renishaw representative.



RTLA50 scale and FASTRACK carrier specifications

	RTLA50 scale	FASTRACK carrier
Form (height × width)	0.2 mm × 8 mm	0.4 mm × 18 mm (including adhesive)
Pitch	50 μm	N/A
Maximum length	10.2 m	25 m ¹
Accuracy (at 20 °C)	±10 μm/m, calibration traceable to International Standards	N/A
Material	Hardened and tempered martensitic stainless steel	
Mass	12.2 g/m	24 g/m
Coefficient of thermal expansion (at 20 °C)	10.1 ±0.2 μm/m/°C	
Mounting	Sits in the FASTRACK carrier	Self-adhesive backing tape
Installation temperature	+15 °C to +35 °C	
Datum fixing	Loctite® 435™ (P-AD03-0012)	

¹ The minimum recommended length is 100 mm

www.renishaw.com/contact

 #renishaw

 **+44 (0) 1453 524524**  **uk@renishaw.com**

© 2016–2026 Renishaw plc. All rights reserved. This document may not be copied or reproduced in whole or in part, or transferred to any other media or language by any means, without the prior written permission of Renishaw.
RENISHAW® and the probe symbol are registered trade marks of Renishaw plc. Renishaw product names, designations and the mark 'apply innovation' are trade marks of Renishaw plc or its subsidiaries. BiSS® is a registered trade mark of iC-Haus GmbH. DRIVE-CLiQ is a registered trademark of Siemens. Other brand, product or company names are trade marks of their respective owners.
Renishaw plc. Registered in England and Wales. Company no: 1106260. Registered office: New Mills, Wotton-under-Edge, Glos, GL12 8JR, UK.

WHILE CONSIDERABLE EFFORT WAS MADE TO VERIFY THE ACCURACY OF THIS DOCUMENT AT PUBLICATION, ALL WARRANTIES, CONDITIONS, REPRESENTATIONS AND LIABILITY, HOWSOEVER ARISING, ARE EXCLUDED TO THE EXTENT PERMITTED BY LAW. RENISHAW RESERVES THE RIGHT TO MAKE CHANGES TO THIS DOCUMENT AND TO THE EQUIPMENT, AND/OR SOFTWARE AND THE SPECIFICATION DESCRIBED HEREIN WITHOUT OBLIGATION TO PROVIDE NOTICE OF SUCH CHANGES.

Part no.: M-6183-9040-04-C
Issued: 03.2026