

OMI-2T optical machine interface



Compliance information for this product is available by scanning the QR code or visiting www.renishaw.com/mtpdoc



Contents

Before you begin	1-1
Warranty	1-1
CNC machines	1-1
Care of the interface	1-1
Patents	1-1
OMI-2T software notices	1-2
Intended use	1-2
Safety	1-3
Information to the user	1-3
Information to the machine supplier / installer	1-3
Information to the equipment installer	1-3
Equipment operation	1-3
Optical safety	1-4
OMI-2T basics	2-1
Introduction	2-1
Power supply	2-1
Input voltage ripple	2-1
OMI-2T visual diagnostics	2-2
Magnetic label	2-2
START SIGNAL LED (yellow)	2-3
LOW BATTERY LED (red)	2-3
PROBE STATUS LED (green, red)	2-3
ERROR LED (red, blue, yellow, violet)	2-3
SIGNAL CONDITION LED (red, yellow, green)	2-3
ACTIVE SYSTEM LEDs (green)	2-4
OMI-2T inputs:	2-4
OMI-2T outputs	2-5
OMI-2T output waveforms	2-6
Switches SW1 and SW2	2-7
Switch-on / switch-off	2-8
Switch-on / switch-off method	2-8
OMI-2T dimensions	2-9
OMI-2T specification	2-10

System installation	3-1
Mounting bracket (optional)	3-1
Wiring diagram (with output groupings shown)	3-2
O MI-2T cable	3-3
Cable sealing	3-3
Fitting flexible conduit	3-4
Screw torque values Nm (lbf.ft)	3-5
Maintenance	4-1
Cleaning the window	4-1
Removing the O MI-2T window	4-2
Fitting the O MI-2T window	4-3
Fault-finding	5-1
Parts list	6-1

Before you begin

Warranty

Unless you and Renishaw have agreed and signed a separate written agreement, the equipment and/or software are sold subject to the Renishaw Standard Terms and Conditions supplied with such equipment and/or software, or available on request from your local Renishaw office.

Renishaw warrants its equipment and software for a limited period (as set out in the Standard Terms and Conditions), provided that they are installed and used exactly as defined in associated Renishaw documentation. You should consult these Standard Terms and Conditions to find out the full details of your warranty.

Equipment and/or software purchased by you from a third-party supplier is subject to separate terms and conditions supplied with such equipment and/or software. You should contact your third-party supplier for details.

CNC machines

CNC machine tools must always be operated by fully-trained personnel in accordance with the manufacturer's instructions.

Care of the interface

Keep system components clean and treat the unit as a precision tool. Do not apply labels to the front of the OMI-2T or otherwise obstruct the window.

Patents

None applicable.

OMI-2T software notices

This OMI-2T product includes embedded software (firmware) to which the following notices apply:

USA government notice

NOTICE TO UNITED STATES GOVERNMENT CONTRACT AND PRIME CONTRACT CUSTOMERS

This software is commercial computer software that has been developed by Renishaw exclusively at private expense. Notwithstanding any other lease or licence agreement that may pertain to, or accompany the delivery of, this computer software, the rights of the United States Government and/or its prime contractors regarding its use, reproduction and disclosure are as set forth in the terms of the contract or subcontract between Renishaw and the United States Government, civilian federal agency or prime contractor respectively. Please consult the applicable contract or subcontract and the software licence incorporated therein, if applicable, to determine your exact rights regarding use, reproduction and/or disclosure.

Renishaw software EULA

Renishaw software is licensed in accordance with the Renishaw licence at:
www.renishaw.com/legal/softwareterms

Intended use

The OMI-2T combined optical transceiver and machine interface must only be used as intended. It is intended for use on machine tools to convert signals from the optical probe into voltage-free solid state relay (SSR) and drive outputs for transmission to the CNC machine tool controller. The OMI-2T must only be used within the environmental conditions specified in this guide.

Safety

Information to the user

In all applications involving the use of machine tools, eye protection is recommended.

The OMI-2T has a glass window. Handle with care if broken to avoid injury.

Information to the machine supplier / installer

It is the machine supplier's responsibility to ensure that the user is made aware of any hazards involved in operation, including those mentioned in Renishaw product literature, and to ensure that adequate guards and safety interlocks are provided.

If the probe system fails, the probe signal may falsely indicate a probe seated condition. Do not rely on probe signals to halt the movement of the machine.

Information to the equipment installer

All Renishaw equipment is designed to comply with the relevant UK, EU and FCC regulatory requirements. It is the responsibility of the equipment installer to ensure that the following guidelines are adhered to, in order for the product to function in accordance with these regulations:

- Any interface **MUST** be installed in a position away from any potential sources of electrical noise, (for example power transformers, servo drives).
- All 0 V/ground connections should be connected to the machine "star point" (the "star point" is a single point return for all equipment ground and screen cables). This is very important and failure to adhere to this can cause a potential difference between grounds.
- All screens must be connected as outlined in the user instructions.
- Cables must not be routed alongside high current sources (for example, motor power supply cables), or be near high-speed data lines.
- Cable lengths should always be kept to a minimum.
- the dc supply to this equipment must be derived from a source which is approved to IEC 62368-1.

Equipment operation

If this equipment is used in a manner not specified by the manufacturer, the protection provided by the equipment may be impaired.

Optical safety

This product contains LEDs that emit both visible and invisible light.

OMI-2T is ranked Risk Group: Exempt (safe by design).

The product was evaluated and classified using the following standard:

BS EN 62471:2008 The photobiological safety of lamps and lamp systems.
(IEC 62471:2006)

Renishaw recommends that you do not stare at or look directly into any LED device, irrespective of its risk classification.

OMI-2T basics

Introduction

The OMI-2T is a combined optical receiver and machine interface which is designed to be mounted within the machine's working envelope.

The OMI-2T operates using a modulated optical transmission mode and is compatible with machine probes that also operate in modulated mode.

Power supply

The OMI-2T can draw its supply from the CNC machine's nominal 12 Vdc to 30 Vdc supply.

The maximum supply current is 160 mA when the OMI-2T is transmitting and 40 mA when the OMI-2T is receiving.

The values quoted are based on a 24 Vdc and assume all outputs are open circuit.

CAUTION: This equipment will only perform to specification if the power supply 0 V is connected to the machine ground (star point).

Input voltage ripple

The input voltage ripple must not cause the voltage to fall below 12 V or rise above 30 V.

OMI-2T visual diagnostics

A visual indication of system status is provided by LEDs. Indication is provided for:

- START
- PROBE STATUS
- SIGNAL
- LOW BATTERY
- ERROR
- ACTIVE SYSTEM.

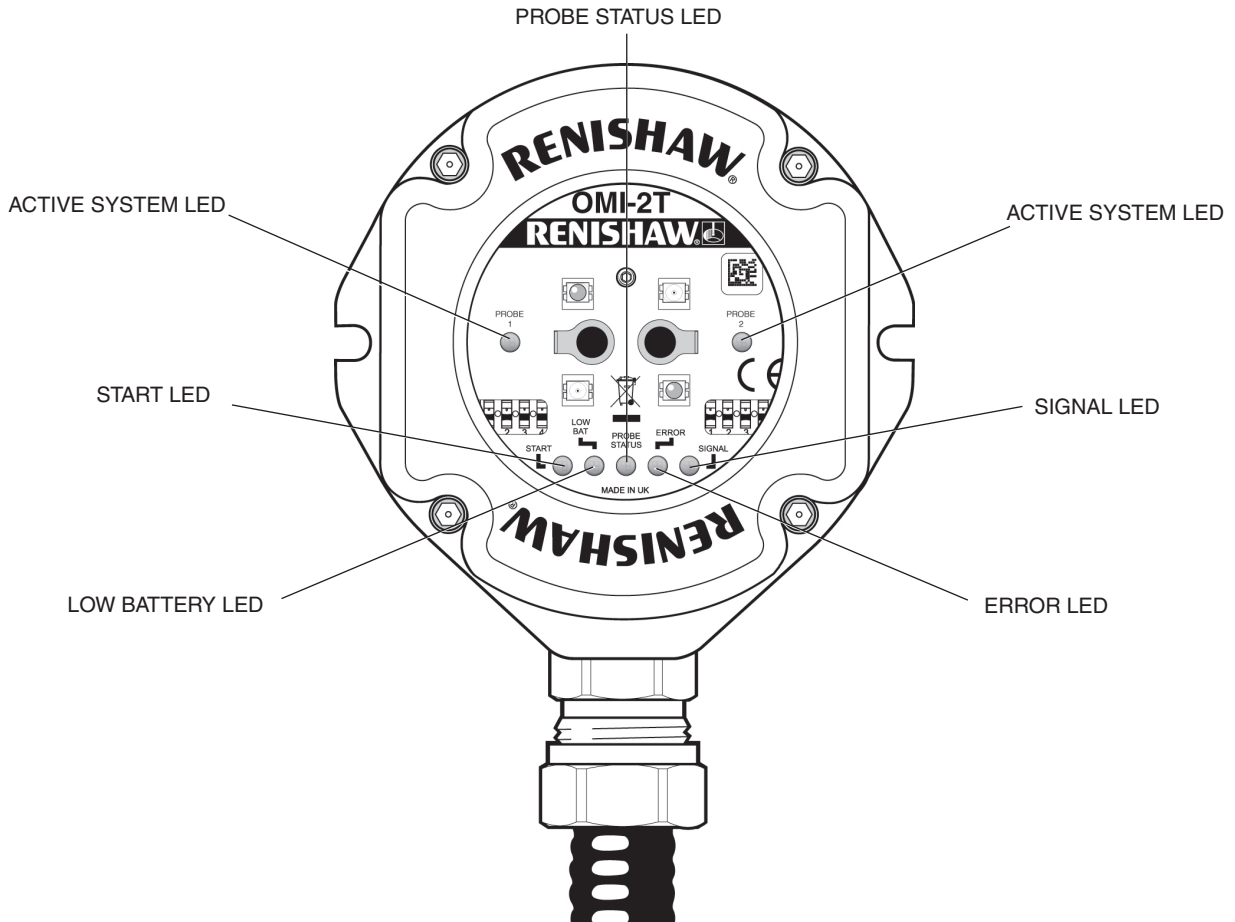

NOTE: Keep the window clean (for more information, see page 4-1, “Cleaning the window”).

Magnetic label

A summary of OMI-2T LED activity is provided on a magnetic label. The label may be placed on any machine flat metal surface.

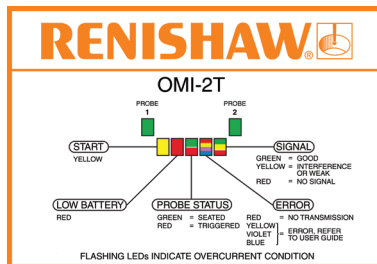

START SIGNAL LED (yellow)

This LED will either flash once when a “Machine Start” signal is commanded.

LOW BATTERY LED (red)

The LED is lit when the activated probe battery voltage falls below a set level.

Replace the probe battery as soon as is practicable after this LED is lit.

PROBE STATUS LED (green, red)

This bicolour LED is lit when the OMI-2T is powered.

- Green – Probe is seated.
- Red – Probe is triggered or an error has occurred.

The change of colour of this LED will coincide with the probe status output devices changing state.

ERROR LED (red, blue, yellow, violet)

Indicates a transmission error condition, for example, optical beam obstructed, probe out of optical range, probe switched off or battery dead.

- Red – No transmission:
There is no signal from the probe.
- Blue – Multiple probe detected:
A second modulated signal is being received.
- Yellow – Interference:
Either the signal received from the probe is too weak, or interference is present.
- Violet – Gauging:
Interference or a weak probe signal has caused the trigger instant to be delayed.

NOTE: The indication of a blue, yellow or violet error condition resulting from the loss of a good probe signal will persist until the active system input (Probe 1 or Probe 2) is deactivated.

SIGNAL CONDITION LED (red, yellow, green)

This tricolour LED is lit when the OMI-2T is powered and indicates as follows:

- Red – No transmission:
There is no signal from the probe.
- Yellow – Interference:
Either the signal received from the probe is too weak, or interference is present.
- Green – Good communications:
The condition of signal received from the probe is good.

ACTIVE SYSTEM LEDs (green)

The LEDs are lit green to show which system input (Probe 1 or Probe 2) is active. Providing the relevant probe is in range and operational, it will be active as long as the LED is lit.

Off when system input is inactive.

OMI-2T inputs:

There are two inputs:

- Probe 1 start
- Probe 2 start

Level	10 V to 30 V (10 mA at 24 V) When the input is active, the probe is switched on.
-------	---

The OMI-2T uses level machine inputs to define the active probe. When the respective input is active, the probe is switched on.

If both inputs are active the system will default to error.

OMI-2T outputs

There are four outputs:

- Probe status 1 (SSR).
- Probe status 2 (SSR).
- Error (SSR).
- Low battery (SSR).

All outputs can be inverted by using switches SW1 and SW2, (for further information, see **page 2-7**, “Switches SW1 and SW2”).

Probe status 1, Error, Low battery (SSR):

- “On” resistance = 50 Ω max.
- Load voltage = 40 V max.
- Load current = 100 mA max.

Switching times (with 10 mA load)

- Open to closed = 100 μ s max.
- Closed to open = 25 μ s max.

Both of the probe status outputs indicate the status of the selected probe (only one probe can be selected at a time). They are both individually configurable.

The Low battery, Probe status, and Error LEDs will start flashing red when an output overload has occurred. Probe status output will be triggered (SSR open). If this occurs, turn off the power supply and remove the source of the problem. Turning on the power supply will reset the OMI-2T.

CAUTIONS:

Power supply voltage

Do not exceed 30 V between: the black wire and the screen wire (green/yellow); the red wire and screen wire (green/yellow); or the red and black wires (power supply); as this could result in permanent damage to the OMI-2T and/or the customer power supply.

The use of in-line fuses at the machine cabinet end is recommended to provide protection for the OMI-2T and cable.

Screen connection

A good connection must be made to machine ground (“star point”).

Output

Ensure that output from the OMI-2T do not exceed specified current ratings.

OMI-2T output waveforms

NOTE: Outputs can be inverted by using switches SW1 and SW2 (for further information, see **page 2-7**, “Switches SW1 and SW2”).

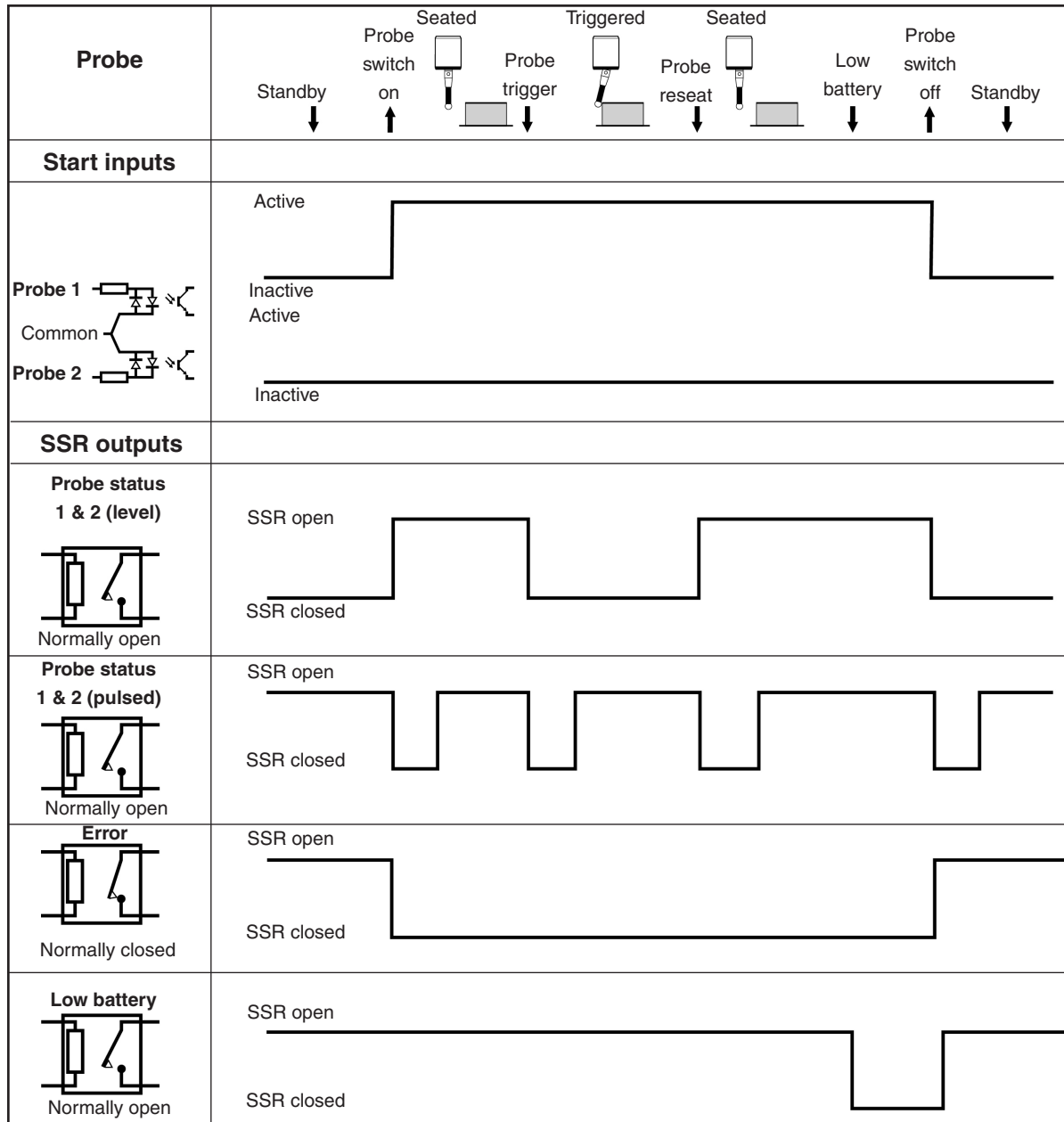

SIGNAL DELAYS

- Transmission delay** Probe trigger to output change of state = 1.3 ms max.
- Start delay** Time from initiation of start signal to valid signal transmission = 410 ms max. for kinematic probes and 1 second max. for strain gauge probes.

NOTES:

Pulsed outputs are 44 ms ±1 ms duration.

Minimum duration of error output is 250 ms nominal.

An error will cause the SSR outputs to latch in the probe standby state until the start input is reactivated.

Switches SW1 and SW2

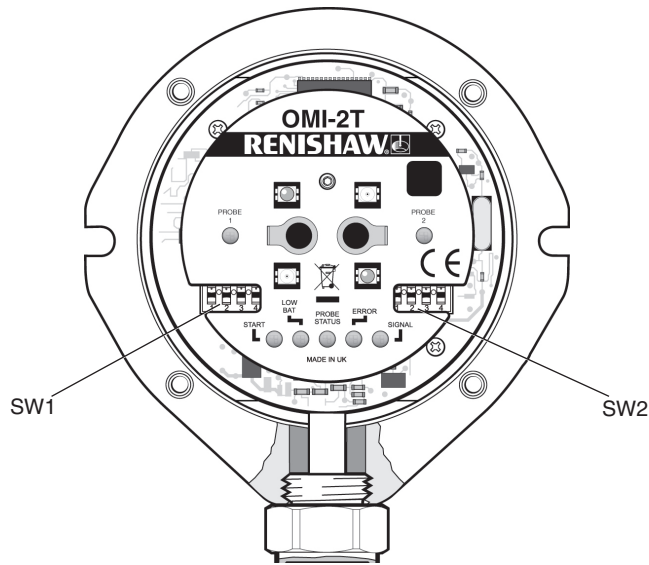

NOTE: To gain access to the switches, remove the window, (for more information, see **page 4-2**, “Removing the OMI-2T window”).

Switch SW1 output configuration

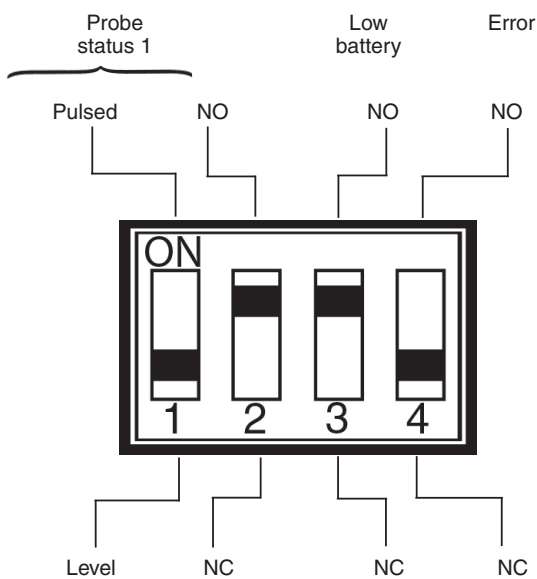

Factory settings for part numbers:

- A-5439-0049
- A-5439-0050

Switch SW2 output configuration

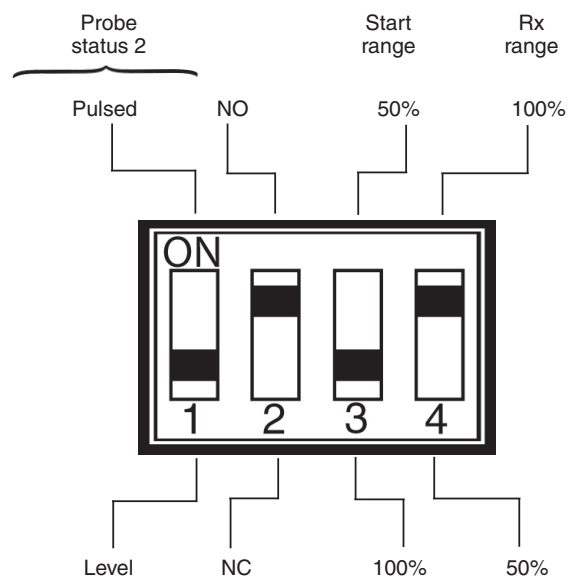

Abbreviations are as follows:

- NO = Normally open
- NC = Normally closed

CAUTION: When using error or probe SSR in NO mode, a wiring fault could cause loss of error condition and therefore could result in a non-failsafe condition.

Switch-on / switch-off

Switch-on / switch-off method

The OMI-2T operates using only optical on / optical off as the switch-on / switch-off method.

Optical on / optical off is available with all Renishaw's OMP range of spindle probes and the optical tool setter (OTS). Time out, spin on / spin off and shank on / shank off options are not compatible with the OMI-2T.

Start-up times

In normal operation the start-up time for a modulated probe (as reported by the OMI-2T error signal) is 410 ms max. for kinematic probes and 1 second max. for strain gauge probes.

The turn off time is 0 seconds.

Normal operation refers to when the on / off status of the probes is in synchronisation with the receiver on / off status. The active probe should correspond to the respective active system LED.

When changing from Probe 1 to Probe 2, or Probe 2 to Probe 1, allow 1 second between the cancelling of one machine start input and raising of the other start input, also allow 1 second when turning the probe off and back on again.

Synchronisation recovery

Under abnormal operating situations the system may lose synchronisation between the receiver and probes. An internal synchronisation recovery will be initiated when the next machine input is received.

The maximum time for system recovery from an abnormal operating situation is 3.5 seconds. Such a time delay could cause a machine alarm if controllers require ready signals within a time of less than 3.5 seconds.

NOTE: When used in conjunction with an OMP400 or OMP600, ensure the probe is set to the standard switch-on delay.

OMI-2T dimensions

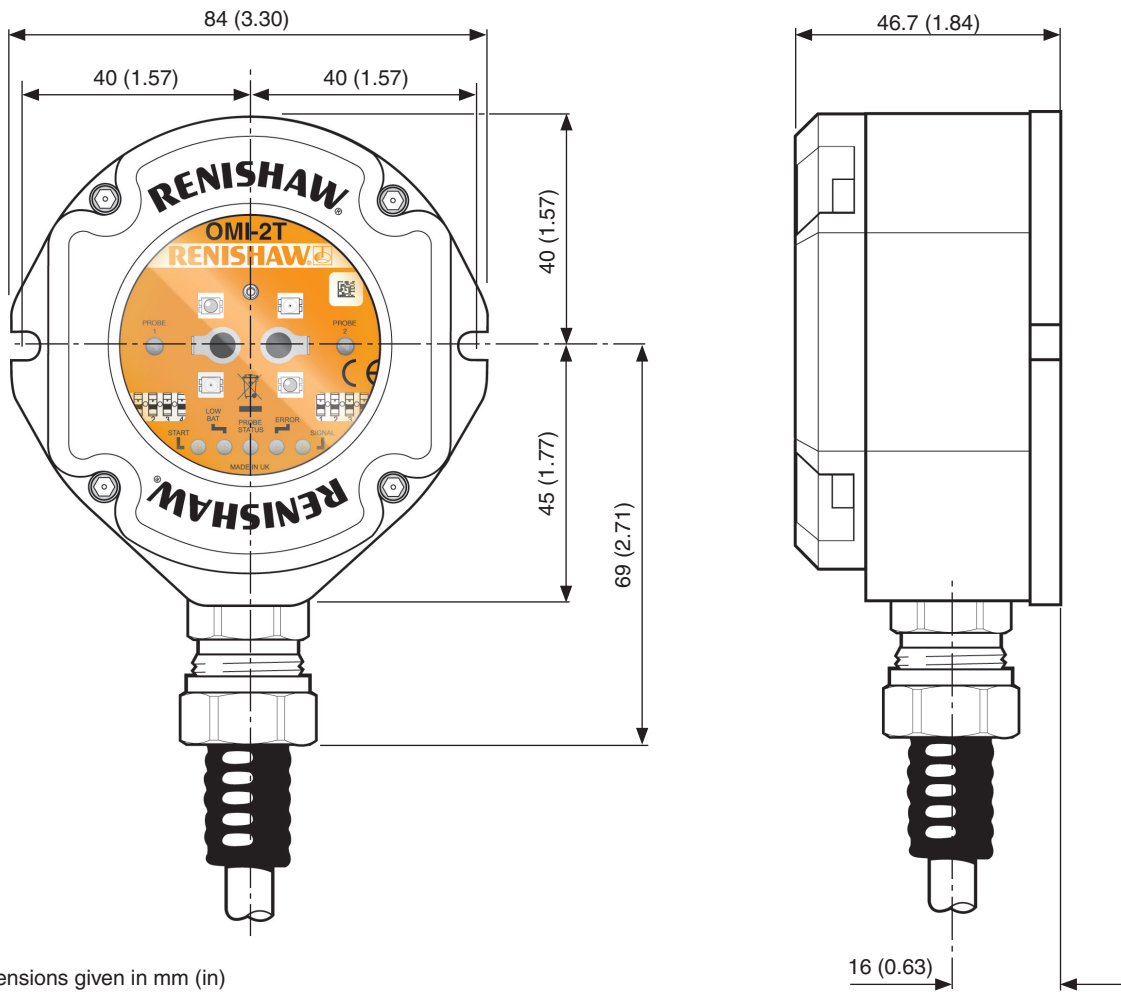

Dimensions given in mm (in)

OMI-2T specification

Principal application	The OMI-2T processes signals from RENGAGE™ technology or standard probes, and converts them into machine outputs, which are then transmitted to the CNC control. The system allows two probes to be used with one interface.	
Weight	OMI-2T including 8 m (26.2 ft) of cable = 955 g (33.69 oz) OMI-2T including 15 m (49.2 ft) of cable = 1495 g (52.73 oz)	
Transmission type	Infrared optical transmission (modulated)	
Probes per system	Two	
Compatible probes	Component setting/inspection: OMP40-2, OMP40M, OMP60, OMP60M, OMP400, OMP600 Lathe inspection: OLP40 Tool setting: OTS	
Operating range	Up to 6 m (19.7 ft)	
Supply voltage	12 Vdc to 30 Vdc (for further information, see page 3-2 “Wiring diagram”)	
Supply current	Transmitting: 160 mA max. peak Receiving: 40 mA average. NOTE: @24 Vdc, all outputs open circuit.	
M-code inputs	Level 10 V to 30 V (10 mA @ 24 V)	
Output signal	Probe Status 1, Probe status 2, Low battery, Error Voltage-free solid-state relay (SSR) outputs, configurable normally open or normally closed. Switching times (with 10 mA load), open to closed 100 µs max., closed to open 25 µs max.	
Input / output protection	Supply protected by resettable fuse. Outputs protected by over current protection circuit.	
Diagnostic LEDs	Start, Low battery, Probe status, Error, Active system and Signal condition.	
Cable (to machine controller)	Specification	Ø7.5 mm (0.29 in), 13-core screened cable, each core 18 × 0.1 mm
	Length	8 m (26.2 ft) and 15 m (49.2 ft)
Mounting	Flush mounting or directional mounting with optional mounting bracket (available separately).	
Environment	IP rating	IPX8, BS EN 60529:1992+A2:2013
	IK rating	IK03 BS EN IEC 62262: 2002+A1:2021
	Storage temperature	–25 °C to +70 °C (–13 °F to +158 °F)
	Operating temperature	+5 °C to +55 °C (+41 °F to +131 °F)
	Indoor/outdoor use	Indoor use
	Altitude	≤ 3000 m (9843 ft)
	Relative humidity	5% to 95%
	Wet location	Yes, water/oil/coolant
	Pollution degree	Level 2

System installation

Mounting bracket (optional)

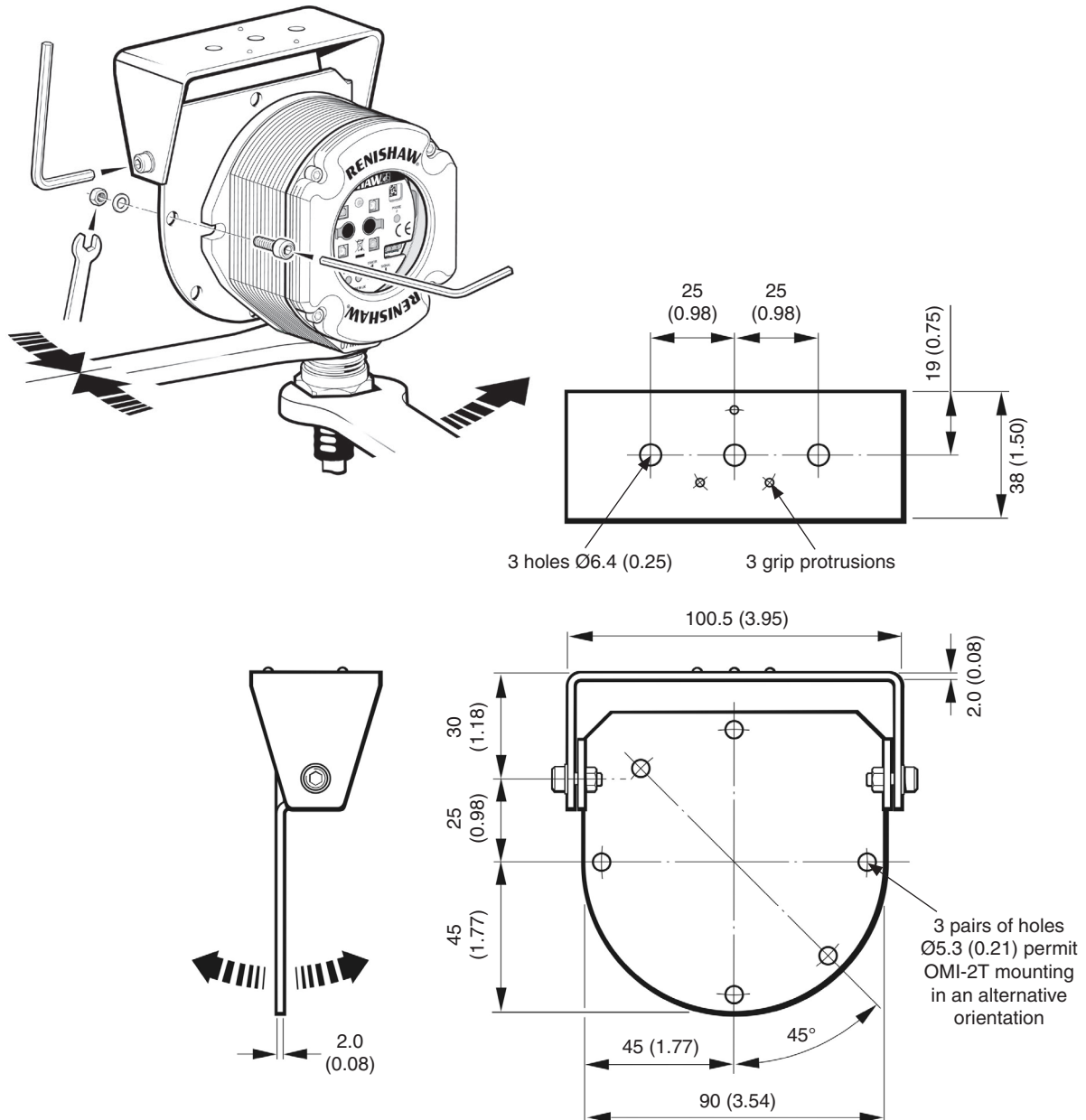

Dimensions given in mm (in)

NOTE: Install the OMI-2T with cable exiting from lower side for good coolant run off.

Wiring diagram (with output groupings shown)

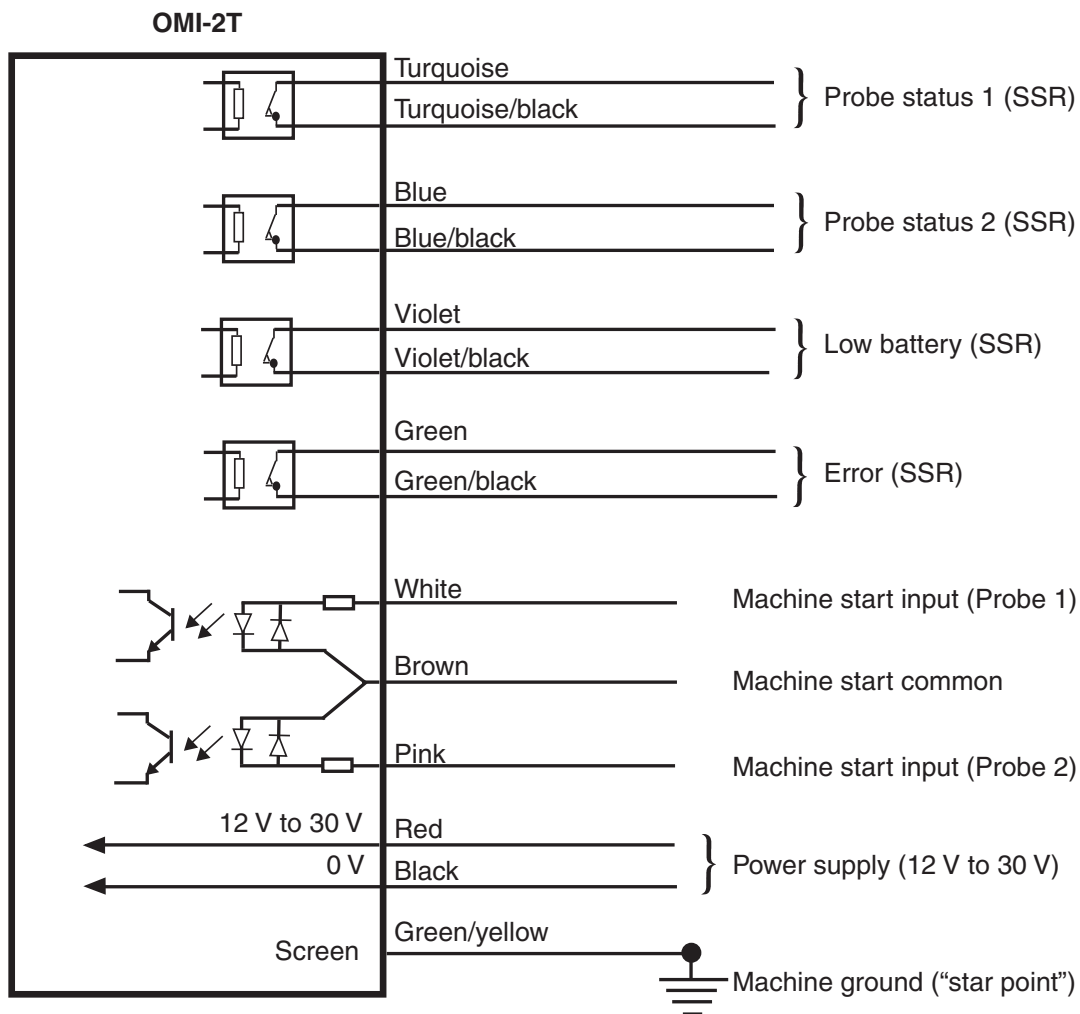

CAUTIONS:

The power supply 0 V should be terminated at the machine ground (star point). If a negative supply is used then the negative output must be fused.

The dc supply to this equipment must be derived from a source which is approved to BS EN IEC 62368-1.

OMI-2T cable

Cable termination

A ferrule should be crimped onto each cable wire for a more positive connection at the terminal box.

Standard cable variants

The OMI-2T standard polyurethane cables are 8 m (26 ft) and 15 m (49.2 ft) long.

Please contact Renishaw for other cable lengths.

Cable specification

Ø7.5 mm (0.29 in), 13 core screened cable, each core 18 × 0.1 mm.

NOTE: Maximum length of the specified cable must not exceed 25 m (82 ft).

Cable sealing

Coolant and dirt are prevented from entering the OMI-2T by the cable sealing gland. The OMI-2T cable can be protected against physical damage by fitting a flexible conduit if required.

A recommended flexible conduit is Anamet™ Sealtite HFX (5/16 in) polyurethane.

A conduit kit is available (see **page 6-1**, “Parts list”).

CAUTIONS:

Failure to adequately protect the cable can result in system failure due to either cable damage or coolant ingress through cores into the OMI-2T.

Failure due to inadequate cable protection will invalidate the warranty.

When tightening or loosening nut **B** on the conduit, ensure that torque is only applied between **A** and **B**.

Fitting flexible conduit

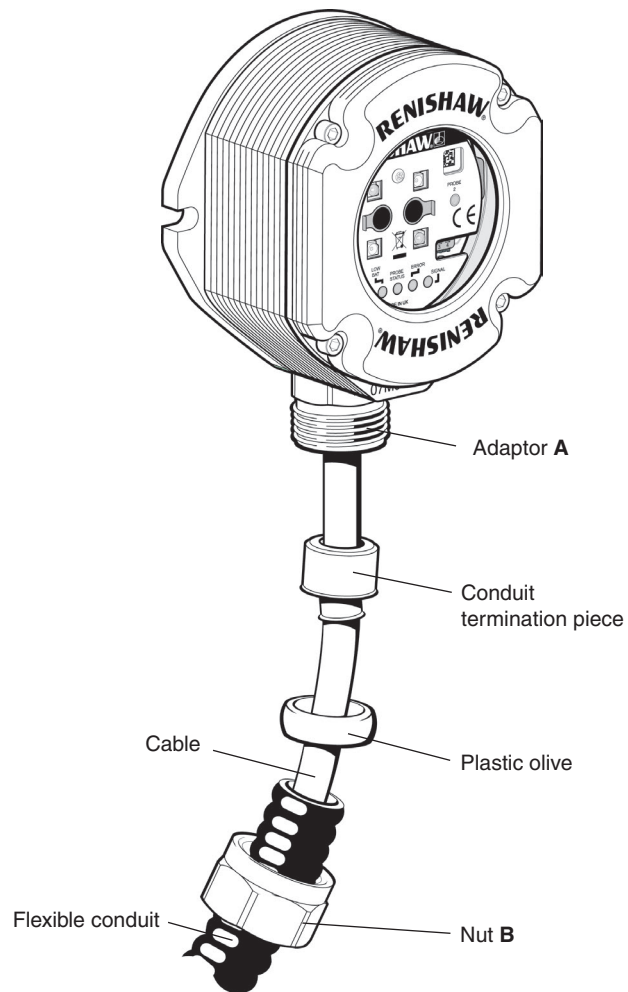

NOTE: Conduit bulkhead fittings require a clearance hole for an M16 thread.

1. Slide nut **B** and the plastic olive onto the conduit.
2. Screw the conduit termination piece into the end of the conduit.
3. Fit the conduit to adaptor **A** and tighten nut **B**.

Screw torque values Nm (lbf.ft)

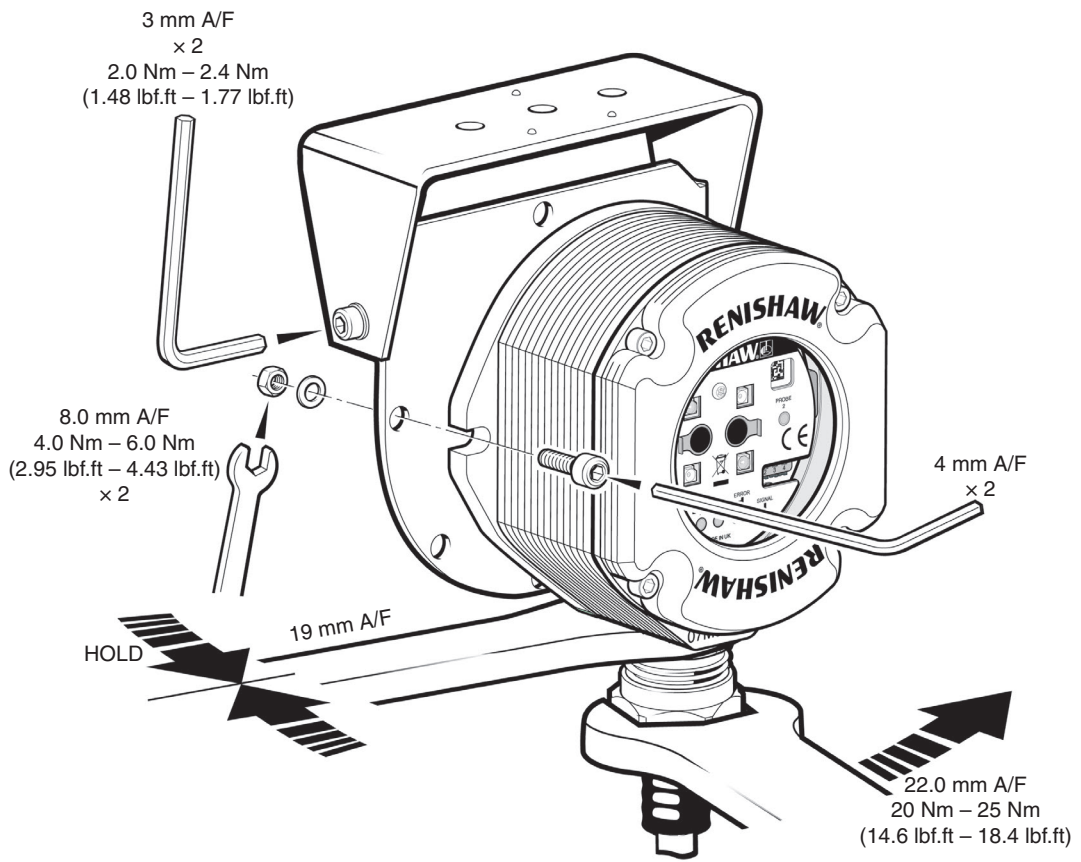

This page is intentionally left blank.

Maintenance

You may undertake the maintenance routines described in these instructions.

Further dismantling and repair of Renishaw equipment is a highly specialised operation, which must be carried out at an authorised Renishaw Service Centre.

Equipment requiring repair, overhaul or attention under warranty should be returned to your supplier.

Cleaning the window

Wipe the window of the interface with a clean cloth to remove machining residue. This should be done on a regular basis to maintain optimum transmission.

CAUTION: The OMI-2T has a glass window. Handle with care if broken to avoid injury.



Removing the OMI-2T window

It is not necessary to remove the OMI-2T from the machine when adjusting the switch or installing replacement parts.

The window may be removed and replaced as described below to change the switch settings.

To remove the OMI-2T window

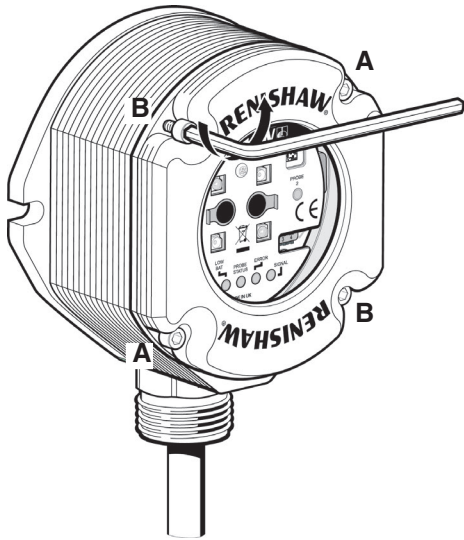

CAUTION: When removing the window, do not twist or rotate by hand.

1. Clean the OMI-2T thoroughly to ensure no debris or coolant enters the unit.
2. Remove the four cover screws, using a 2.5 mm A/F hexagon key. Two screws are short and two are long. Two of the cover holes are threaded **A**, and two are plain **B**.
3. The window fits tightly on the OMI-2T body, and is removed using the two long screws, which are inserted into the threaded holes **A**.
4. Tighten each screw a few turns at a time to pull the window up evenly. When it is clear of the body, remove the window and screws completely.

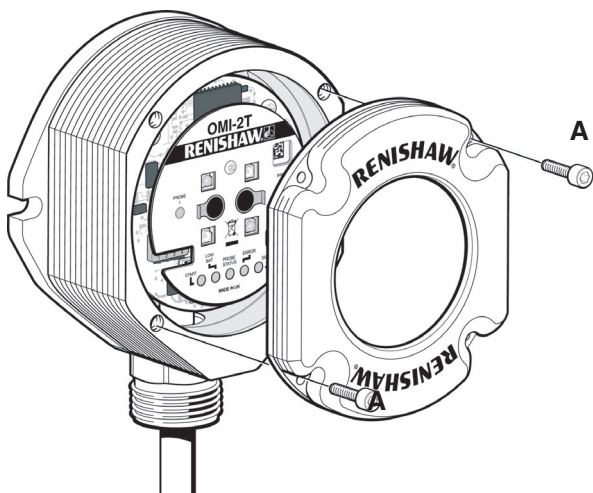

Fitting the OMI-2T window

1. Before fitting the window, check for any damage to screws or scratch marks which could prevent sealing.
2. Ensure the O-ring seating **C** in the OMI-2T body is clean.

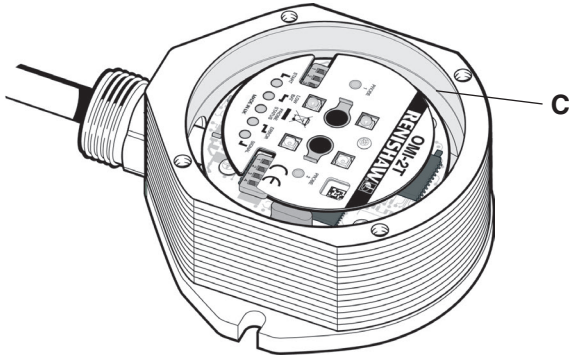

3. Ensure that the O-ring **D** and window **E** are clean.

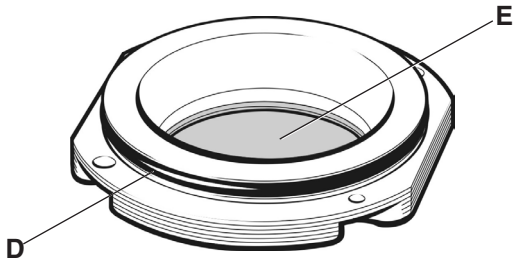

4. Insert the two short screws into window holes **A**, and tighten.

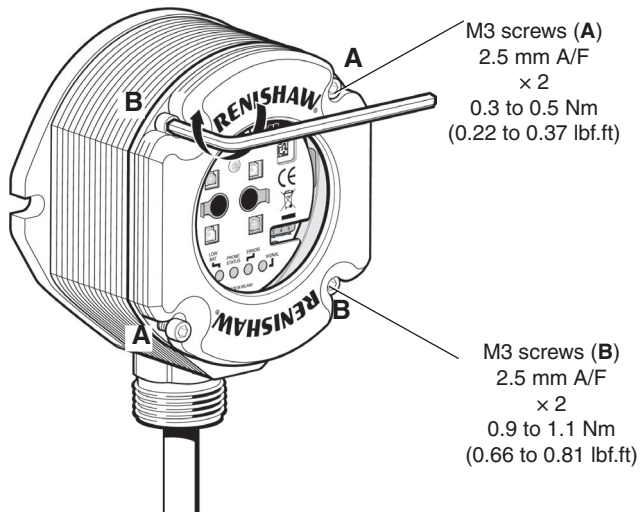

5. Place the window complete with the O-ring onto the OMI-2T body.

NOTE: The O-ring should be lightly lubricated with grease.

6. Insert the long screws into holes **B** and tighten each screw a few turns at a time, to pull the window down evenly. There may be some resistance due to some compression of air trapped inside the body.

This page is intentionally left blank.

Fault-finding

Symptom	Cause	Action
The probe fails to switch on switch off.	Installation / CNC program fault.	Correct the M-code wiring and/or the CNC program.
	Both Probe 1 and Probe 2 LEDs are lit on interface due to both M-codes being active.	Correct M-codes in CNC program.
	The probe is out of the start range.	Change the CNC program to bring the probe within the start range of the OMI-2T and ensure that the appropriate start range is selected.
	The transmission beam is obstructed.	Clean the OMI-2T window and remove any obstructions.
	Incompatible probe / probe transmission setting.	Ensure the probe switch-on / switch-off method is set to optical on / optical off. Change the probe or probe setting to modulated and appropriate start code (Probe 1 and Probe 2, see the probe installation guide).
	Incorrect “machine start” setting.	Reconfigure the “machine start setting SW1 and SW2.
	Dead optical probe batteries.	Change batteries.
Optical interference is blocking the start signal.	Check the OMI-2T visual diagnostics, (for more information, see page 2-2 , “OMI-2T visual diagnostics”). Remove the source of interference or reposition the OMI-2T such that interfering light does not shine onto the OMI-2T window or probe window.	

Symptom	Cause	Action
<p>The probe stops in mid-cycle.</p> <p>or</p> <p>An unexpected error occurs during a probing cycle.</p> <p>or</p> <p>An unexpected trigger occurs during the probing cycle.</p>	The transmission beam is obstructed.	Remove the obstruction.
	Optical interference.	Remove the source of interference or reposition the OMI-2T such that interfering light does not shine into the OMI-2T window.
	Intermittent wiring fault.	Correct wiring.
	The probe has moved outside the reception range.	Change the CNC program to bring the probe within the reception range of the OMI-2T and ensure that the appropriate reception range is selected.
	The probe has not been triggered for more than 90 minutes.	Restart the probe and ensure that the probe is not idle for 90 minutes.
<p>The probe switches on, but the OMI-2T error LED remains lit.</p>	Interfering light source is shining directly into the OMI-2T window.	<p>Check the OMI-2T visual diagnostics, (for more information, see page 2-2, “OMI-2T visual diagnostics”).</p> <p>Remove the source of interference or reposition the OMI-2T such that interfering light does not shine onto the OMI-2T window.</p>
	The probe is out of range.	<p>Check the signal condition LED.</p> <p>Change the CNC program to move the probe into the reception range of the OMI-2T and ensure the appropriate reception range is selected.</p>
	A signal is being received from a probe on an adjacent machine tool.	Change the adjacent probe to low power mode or change the OMI-2T reception range to 50%, if this range is acceptable.
	Installation / CNC program fault.	Check wiring and CNC program.
<p>The probe indicates low battery condition, but the machine control does not.</p>	Installation / CNC program fault.	Correct low battery SSR wiring and/or CNC program.

Symptom	Cause	Action
The machine control does not respond to the probe being triggered or seated.	Probe is not switched on.	Attempt to switch it on.
	Probe is out of range.	Change the CNC program to bring the probe within the reception range.
	Installation / CNC program fault.	Correct the probe status output(s) wiring and CNC program.
	A signal is being received from a probe on an adjacent machine tool.	Change the adjacent probe to low power mode or change the OMI-2T reception range to 50%, if this range is acceptable.
Probe triggers but the OMI-2T does not respond.	The OMP400 or OMP600 has the 3 second switch-on mode selected.	Reconfigure the OMP400 or OMP600 to the standard switch-on delay.
	The probe is out of range.	Review the performance envelopes.
	The transmission beam obstructed.	Check that the probe and OMI-2T windows are clean, and remove any obstruction.
	The probe is set to legacy transmission.	Reconfigure to modulated transmission.

This page is intentionally left blank.

Parts list

Type	Part number	Description
OMI-2T kit	A-5439-0049	OMI-2T with 8 m (26.2 ft) cable, magnetic label, tools and support card.
OMI-2T kit	A-5439-0050	OMI-2T with 15 m (49.2 ft) cable, magnetic label, tools and support card.
Mounting bracket	A-2033-0830	Mounting bracket.
Conduit kit	A-4113-0306	Conduit kit with 1 m (3.28 ft) of polyurethane conduit and bulkhead connector (M16 thread).
Window replacement kit	A-5191-0019	Comprising: window assembly with O-ring, 3 × stainless steel M3 × 14 mm long screws, 3 × stainless steel M3 × 5 mm long screws and 1 × 2.5 mm hexagon wrench.
Tools	A-5191-0300	Comprising: 1 × 2.5 mm hexagon wrench, 1 × 4 mm hexagon wrench, 14 × ferrules, 2 × M5 screws, 2 × M5 washers and 2 × M5 nuts.
Publications. These can be downloaded from our website at www.renishaw.com		
OMP40-2	H-4071-8504	Installation guide: for set-up of the OMP40-2 optical machine probe.
OLP40	H-5625-8504	Installation guide: for set-up of the OLP40 optical lathe probe.
OMP400	H-5096-8504	Installation guide: for set-up of the OMP400 optical machine probe.
OMP60	H-4038-8505	Installation guide: for set-up of the OMP60 optical machine probe.
OMP600	H-5180-8504	Installation guide: for set-up of the OMP600 optical machine probe.
OTS	H-5514-8504	Installation guide: for set-up of the OTS optical tool setting probe.

NOTE: The serial number of each OMI-2T is found on the bottom of the housing.

www.renishaw.com/contact



#renishaw

 +44 (0) 1453 524524

 uk@renishaw.com

© 2010–2026 Renishaw plc. All rights reserved. This document may not be copied or reproduced in whole or in part, or transferred to any other media or language by any means, without the prior written permission of Renishaw.

RENISHAW® and the probe symbol are registered trade marks of Renishaw plc. Renishaw product names, designations and the mark 'apply innovation' are trade marks of Renishaw plc or its subsidiaries. Other brand, product or company names are trade marks of their respective owners.

WHILE CONSIDERABLE EFFORT WAS MADE TO VERIFY THE ACCURACY OF THIS DOCUMENT AT PUBLICATION, ALL WARRANTIES, CONDITIONS, REPRESENTATIONS AND LIABILITY, HOWSOEVER ARISING, ARE EXCLUDED TO THE EXTENT PERMITTED BY LAW. RENISHAW RESERVES THE RIGHT TO MAKE CHANGES TO THIS DOCUMENT AND TO THE EQUIPMENT, AND/OR SOFTWARE AND THE SPECIFICATION DESCRIBED HEREIN WITHOUT OBLIGATION TO PROVIDE NOTICE OF SUCH CHANGES.

Renishaw plc. Registered in England and Wales. Company no: 1106260. Registered office: New Mills, Wotton-under-Edge, Glos, GL12 8JR, UK.

Part no.: H-5439-8510-05-C

Issued: 06.2026