

# Ri interface cable guide



# System connection

The optional Ri cable guide aids assembly of the connector. There are two versions depending upon which type of readhead is being connected.

| Readhead | Cable guide part number |
|----------|-------------------------|
| ATOM™    | A-9693-2577             |
| TONiC™   | A-9770-0019             |

Approved ESD precautions must be followed at all times during readhead and interface electrical connections. The ATOM and TONiC readheads are connected to the Ri interface via a small, rugged connector to allow for easy feed-through during installation.



## Inserting the Ri cable guide

1. Open the interface housing by removing the 2 screws shown (4-40 UNC screws and nuts).
2. With the plain side uppermost, remove the top half of the housing, so that the interface PCB is exposed and the readhead connection socket is visible.

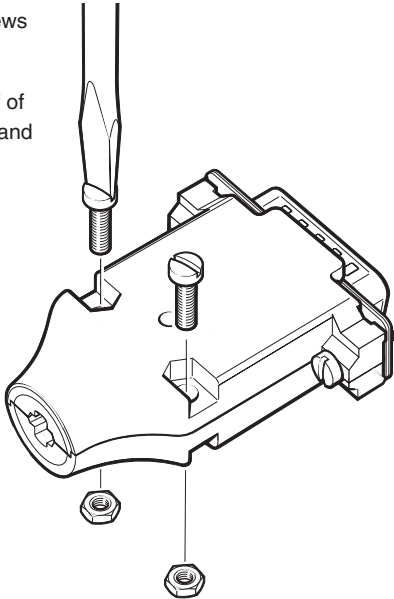

3. Remove the interface PCB and place the appropriate Ri interface cable guide into the bottom half of the housing, ensuring correct orientation as shown.

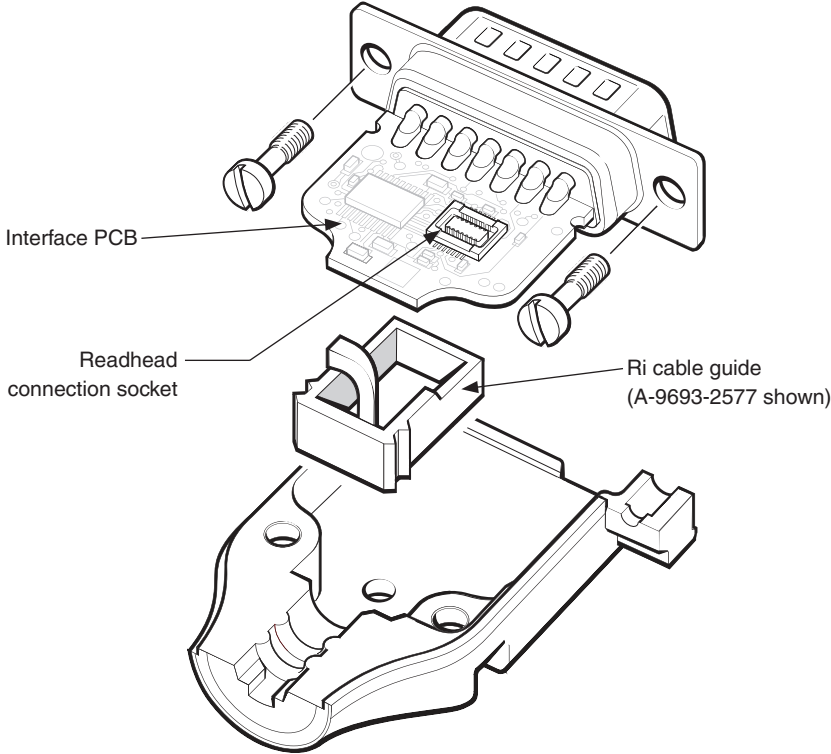

4. Place the interface PCB back into the bottom housing.
5. Taking care not to touch the pins, plug the readhead connector into the socket in the interface, ensuring correct orientation as shown.

---

**NOTE:** Care is required to hold the assembly together as the PCB is fixed only to the 15 way connector and the jack screws are loose.

---

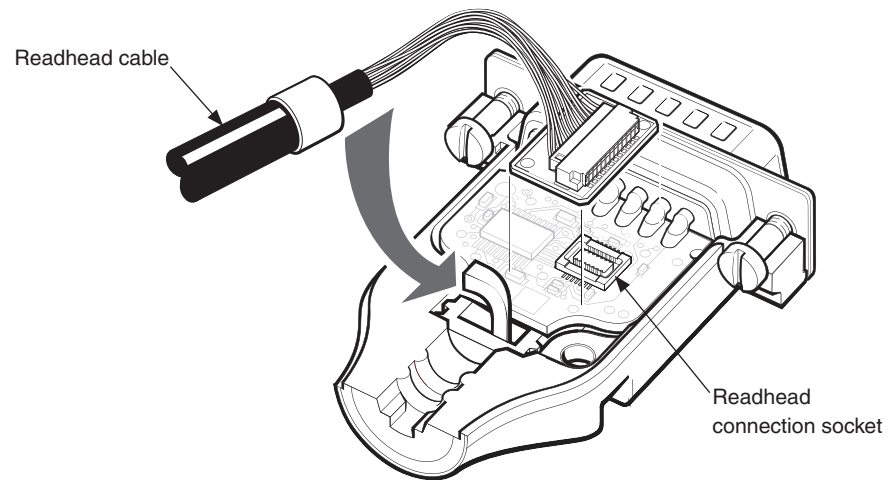

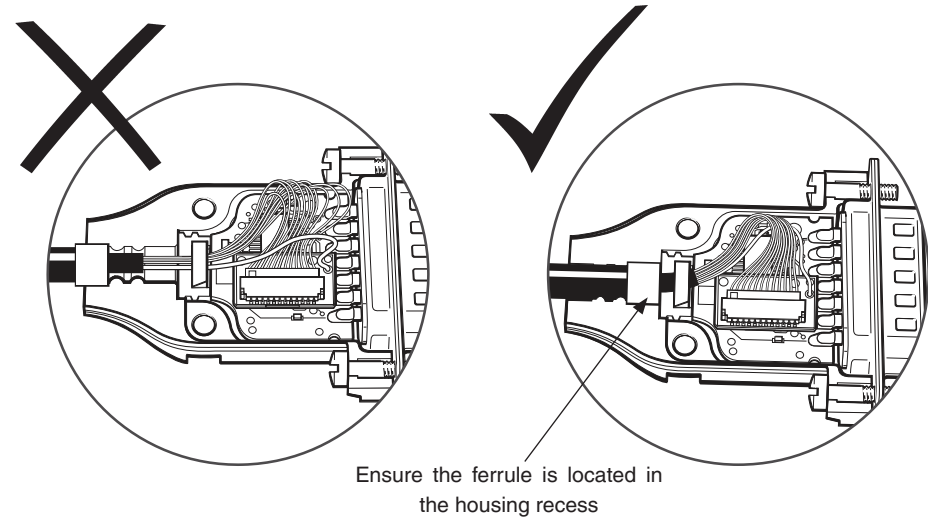

6. Ensure the cable ferrule is located in the recess on the inside of the bottom housing, the cable loops under the Ri cable guide, and no wires are at risk of being trapped, as you re-assemble the housing.
7. Refit the screws.



[www.renishaw.com/contact](http://www.renishaw.com/contact)

 #renishaw

 +44 (0) 1453 524524  [uk@renishaw.com](mailto:uk@renishaw.com)

© 2021–2026 Renishaw plc. All rights reserved. This document may not be copied or reproduced in whole or in part, or transferred to any other media or language by any means, without the prior written permission of Renishaw.  
RENISHAW® and the probe symbol are registered trade marks of Renishaw plc. Renishaw product names, designations and the mark 'apply innovation' are trade marks of Renishaw plc or its subsidiaries. Other brand, product or company names are trade marks of their respective owners. Renishaw plc. Registered in England and Wales. Company no: 1106260. Registered office: New Mills, Wotton-under-Edge, Glos, GL12 8JR, UK.

WHILE CONSIDERABLE EFFORT WAS MADE TO VERIFY THE ACCURACY OF THIS DOCUMENT AT PUBLICATION, ALL WARRANTIES, CONDITIONS, REPRESENTATIONS AND LIABILITY, HOWSOEVER ARISING, ARE EXCLUDED TO THE EXTENT PERMITTED BY LAW. RENISHAW RESERVES THE RIGHT TO MAKE CHANGES TO THIS DOCUMENT AND TO THE EQUIPMENT, AND/OR SOFTWARE AND THE SPECIFICATION DESCRIBED HEREIN WITHOUT OBLIGATION TO PROVIDE NOTICE OF SUCH CHANGES.

Part no.: M-9770-9478-02-B  
Issued: 01.2026