

TONiC™ T1x3x RTLC20/FASTRACK incremental linear encoder system

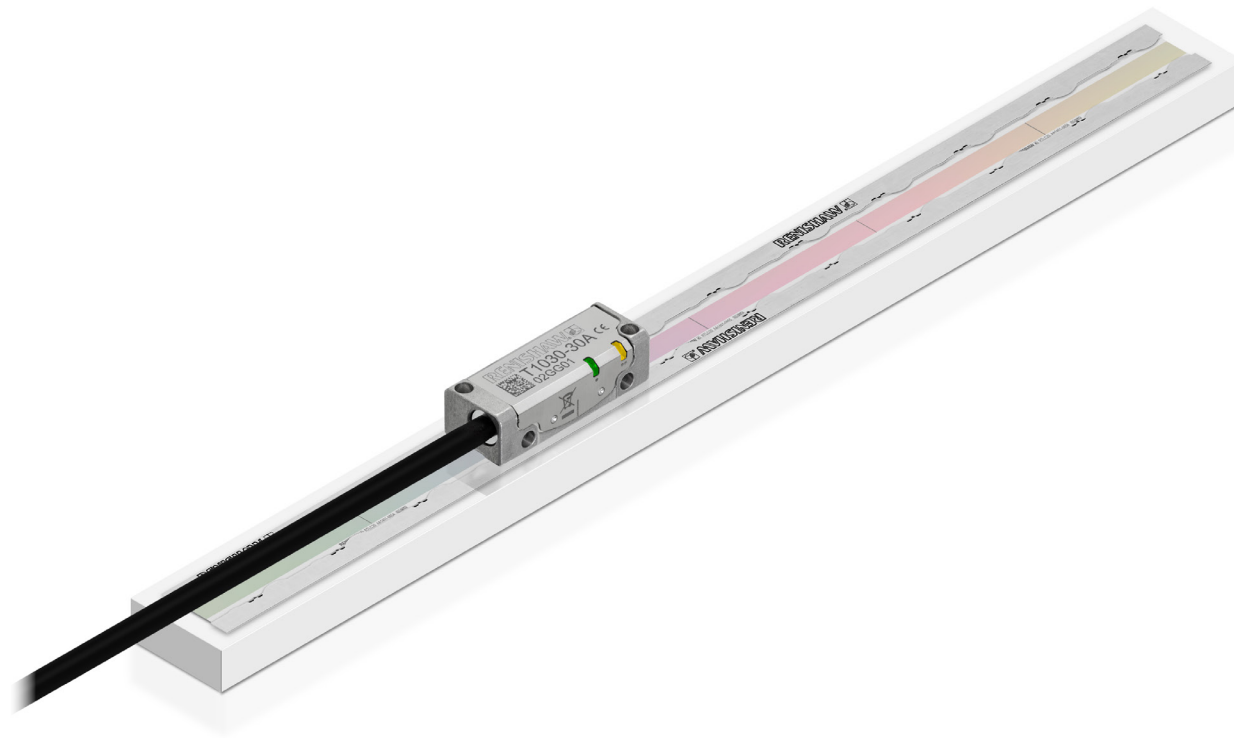

This page is intentionally left blank.

Contents

Legal notices5
Storage and handling9
TONiC T1x3x readhead installation drawing11
Ti/TD interface drawing12
DOP interface drawing13
RTL20/FASTRACK system installation drawing.14
Equipment required for installing the RTL20 scale and the FASTRACK carrier15
Cutting the RTL20 scale and the FASTRACK carrier16
Applying the RTL20 and FASTRACK scale system.18
Reference mark selector and limit magnet installation22
TONiC quick-start guide23
System connection - Ti or TD interfaces.24
System connection - DOP interface26
Readhead mounting and alignment27
System LEDs28
System calibration29
Restoring factory defaults31
Switching Automatic Gain Control (AGC) on or off.31
Output signals.32
Speed35
Electrical connections.36
General specifications44
RTL20 scale specifications45

FASTRACK carrier specifications45
Reference mark46
Limit switches46

Legal notices

Patents

Features of Renishaw's TONiC™, RTLC20, and FASTRACK encoder systems are the subjects of the following patents and patent applications:

EP0748436	US5861953	EP1173731	US6775008B2	JP4750998
CN100543424C	US7659992	JP4932706	CN100507454C	US7550710
EP1766335	CN101300463B	EP1946048	US7624513B2	JP5017275
CN101310165B	US7839296	EP1957943	US8141265	EP2294363
CN102057256	JP5475759	JP5755299	KR20110033204	CN1314511
EP1469969	JP5002559	US8466943	US8987633	

Terms and conditions and warranty

Unless you and Renishaw have agreed and signed a separate written agreement, the equipment and/or software are sold subject to the Renishaw Standard Terms and Conditions supplied with such equipment and/or software, or available on request from your local Renishaw office.

Renishaw warrants its equipment and software for a limited period (as set out in the Standard Terms and Conditions), provided that they are installed and used exactly as defined in associated Renishaw documentation. You should consult these Standard Terms and Conditions to find out the full details of your warranty.

Equipment and/or software purchased by you from a third-party supplier is subject to separate terms and conditions supplied with such equipment and/or software. You should contact your third-party supplier for details.

Declaration of Conformity

Renishaw plc hereby declares that the TONiC™ encoder system is in compliance with the essential requirements and other relevant provisions of:

- the applicable EU directives
- the relevant statutory instruments under UK law



The full text of the declaration of conformity is available at: www.renishaw.com/productcompliance.

Compliance

Federal Code Of Regulation (CFR) FCC Part 15 – RADIO FREQUENCY DEVICES

47 CFR Section 15.19

This device complies with part 15 of the FCC Rules. Operation is subject to the following two conditions: (1) This device may not cause harmful interference, and (2) this device must accept any interference received, including interference that may cause undesired operation.

47 CFR Section 15.21

The user is cautioned that any changes or modifications not expressly approved by Renishaw plc or authorised representative could void the user's authority to operate the equipment.

47 CFR Section 15.105

This equipment has been tested and found to comply with the limits for a Class A digital device, pursuant to part 15 of the FCC Rules. These limits are designed to provide reasonable protection against harmful interference when the equipment is operated in a commercial environment.

This equipment generates, uses, and can radiate radio frequency energy and, if not installed and used in accordance with the instruction manual, may cause harmful interference to radio communications. Operation of this equipment in a residential area is likely to cause harmful interference in which case the user will be required to correct the interference at his own expense.

47 CFR Section 15.27

This unit was tested with shielded cables on the peripheral devices. Shielded cables must be used with the unit to ensure compliance.

Supplier's Declaration of Conformity

47 CFR § 2.1077 Compliance Information

Unique Identifier: TONiC

Responsible Party - U.S. Contact Information

Renishaw Inc.
1001 Wesemann Drive
West Dundee
Illinois
IL 60118
United States
Telephone number: +1 847 286 9953
Email: usa@renishaw.com

ICES-003 – Information Technology Equipment (including Digital Apparatus)

This ISM device complies with Canadian ICES-003(A).

Cet appareil ISM est conforme à la norme ICES-003(A).

Intended use

The TONiC encoder system is designed to measure position and provide that information to a drive or controller in applications requiring motion control. It must be installed, operated, and maintained as specified in Renishaw documentation and in accordance with the Standard Terms and Conditions of the Warranty and all other relevant legal requirements.

Further information

Further information relating to the TONiC and RTLC20/FASTRACK encoder range can be found in the following documents:

<i>TONiC™ encoder system</i> data sheet (Renishaw part no. L-9517-9337)
<i>TONiC™ UHV encoder system</i> data sheet (Renishaw part no. L-9517-9426)
<i>TONiC™ DOP (dual output) encoder system</i> data sheet (Renishaw part no. L-9517-9411)
<i>RTLC incremental linear scale</i> data sheet (Renishaw part no. L-9517-9417)

These can be downloaded from our website at www.renishaw.com/tonicdownloads and are also available from your local Renishaw representative.

Packaging

The packaging of our products contains the following materials and can be recycled.

Packing component	Material	ISO 11469	Recycling guidance
Outer box	Cardboard	Not applicable	Recyclable
	Polypropylene	PP	Recyclable
Inserts	Low density polyethylene foam	LDPE	Recyclable
	Cardboard	Not applicable	Recyclable
Bags	High density polyethylene bag	HDPE	Recyclable
	Metalised polyethylene	PE	Recyclable

REACH regulation

Information required by Article 33(1) of Regulation (EC) No. 1907/2006 ("REACH") relating to products containing substances of very high concern (SVHCs) is available at www.renishaw.com/REACH.

Disposal of waste electrical and electronic equipment

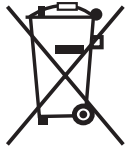

The use of this symbol on Renishaw products and/or accompanying documentation indicates that the product should not be mixed with general household waste upon disposal. It is the responsibility of the end user to dispose of this product at a designated collection point for waste electrical and electronic equipment (WEEE) to enable reuse or recycling. Correct disposal of this product will help to save valuable resources and prevent potential negative effects on the environment. For more information, contact your local waste disposal service or Renishaw distributor.

TONiC software notices

Third party licences

Copyright © 2019, Microchip Technology Inc. and its subsidiaries (“Microchip”)

All rights reserved.

This software is developed by Microchip Technology Inc. and its subsidiaries (“Microchip”).

Redistribution and use in source and binary forms, with or without modification, are permitted provided that the following conditions are met:

- Redistributions of source code must retain the above copyright notice, this list of conditions and the following disclaimer.
- Redistributions in binary form must reproduce the above copyright notice, this list of conditions and the following disclaimer in the documentation and/or other materials provided with the distribution.
- Microchip’s name may not be used to endorse or promote products derived from this software without specific prior written permission.

THIS SOFTWARE IS PROVIDED BY MICROCHIP “AS IS” AND ANY EXPRESS OR IMPLIED WARRANTIES, INCLUDING, BUT NOT LIMITED TO, THE IMPLIED WARRANTIES OF MERCHANTABILITY AND FITNESS FOR PURPOSE ARE DISCLAIMED. IN NO EVENT SHALL MICROCHIP BE LIABLE FOR ANY DIRECT, INDIRECT, INCIDENTAL, SPECIAL, EXEMPLARY, OR CONSEQUENTIAL DAMAGES (INCLUDING BUT NOT LIMITED TO PROCUREMENT OF SUBSTITUTE GOODS OR SERVICES; LOSS OF USE, DATA OR PROFITS; OR BUSINESS INTERRUPTION) HOWSOEVER CAUSED AND ON ANY THEORY OF LIABILITY, WHETHER IN CONTRACT, STRICT LIABILITY, OR TORT (INCLUDING NEGLIGENCE OR OTHERWISE) ARISING IN ANY WAY OUT OF THE USE OF THIS SOFTWARE, EVEN IF ADVISED OF THE POSSIBILITY OF SUCH DAMAGE.

US government notice

NOTICE TO UNITED STATES GOVERNMENT CONTRACT AND PRIME CONTRACT CUSTOMERS

This software is commercial computer software that has been developed by Renishaw exclusively at private expense. Notwithstanding any other lease or licence agreement that may pertain to, or accompany the delivery of, this computer software, the rights of the United States Government and/or its prime contractors regarding its use, reproduction and disclosure are as set forth in the terms of the contract or subcontract between Renishaw and the United States Government, civilian federal agency or prime contractor respectively. Please consult the applicable contract or subcontract and the software licence incorporated therein, if applicable, to determine your exact rights regarding use, reproduction and/or disclosure.

Renishaw End User Licence Agreement (EULA)

Renishaw software is licensed in accordance with the Renishaw licence at:

www.renishaw.com/legal/softwareterms.

Storage and handling

TONiC non-contact optical encoder systems provide good immunity against contaminants such as dust, fingerprints and light oils. However, in harsh environments such as machine tool applications, use protection to prevent ingress of coolant or oil.

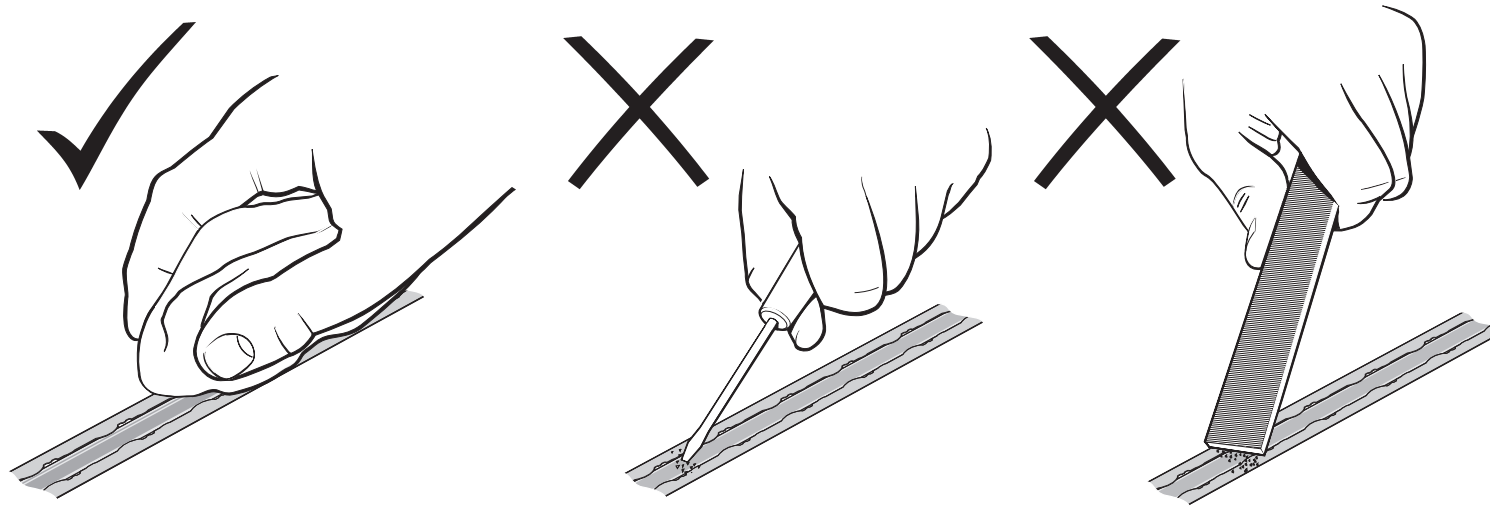

Minimum bend radius

RTL20 scale - 50 mm
 FASTRACK™ carrier - 200 mm

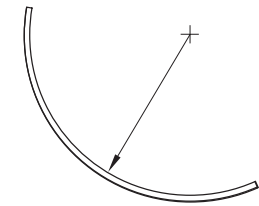

NOTE: Ensure self-adhesive tape is on the outside of bend radius.

Scale and readhead

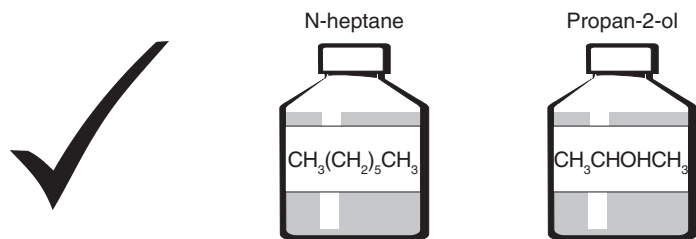

Readhead only

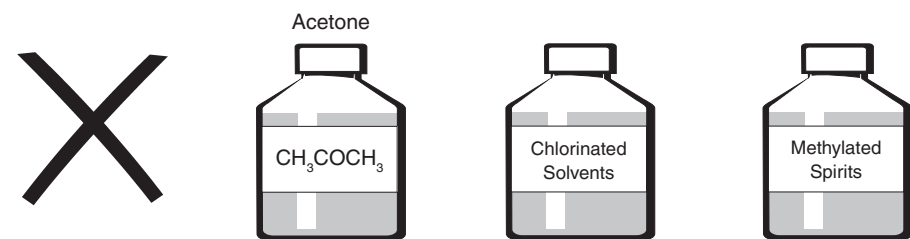

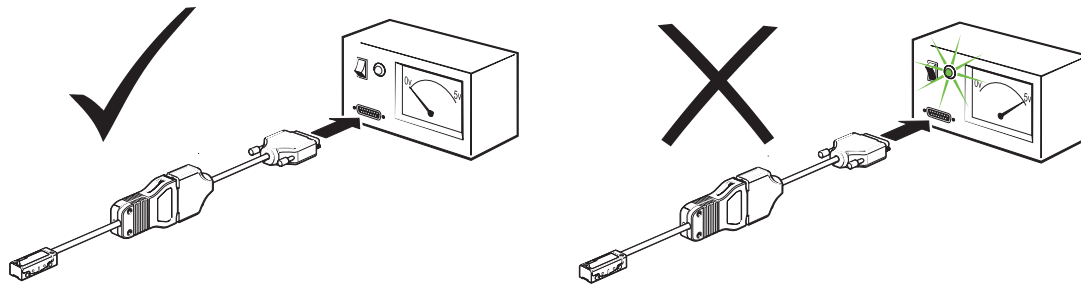

Temperature

Storage	
System	-20 °C to +70 °C

Bakeout	
UHV readhead	+120 °C

Operating	
System	0 °C to +70 °C

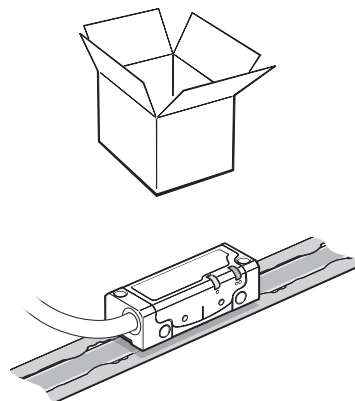

Humidity

95% relative humidity (non-condensing) to IEC 60068-2-78

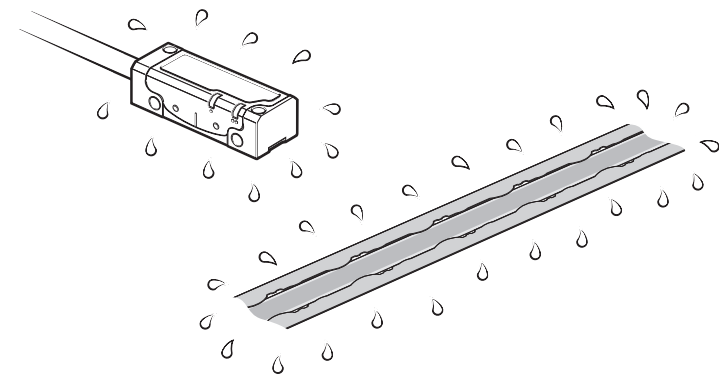

TONiC T1x3x readhead installation drawing

Dimensions and tolerances in mm

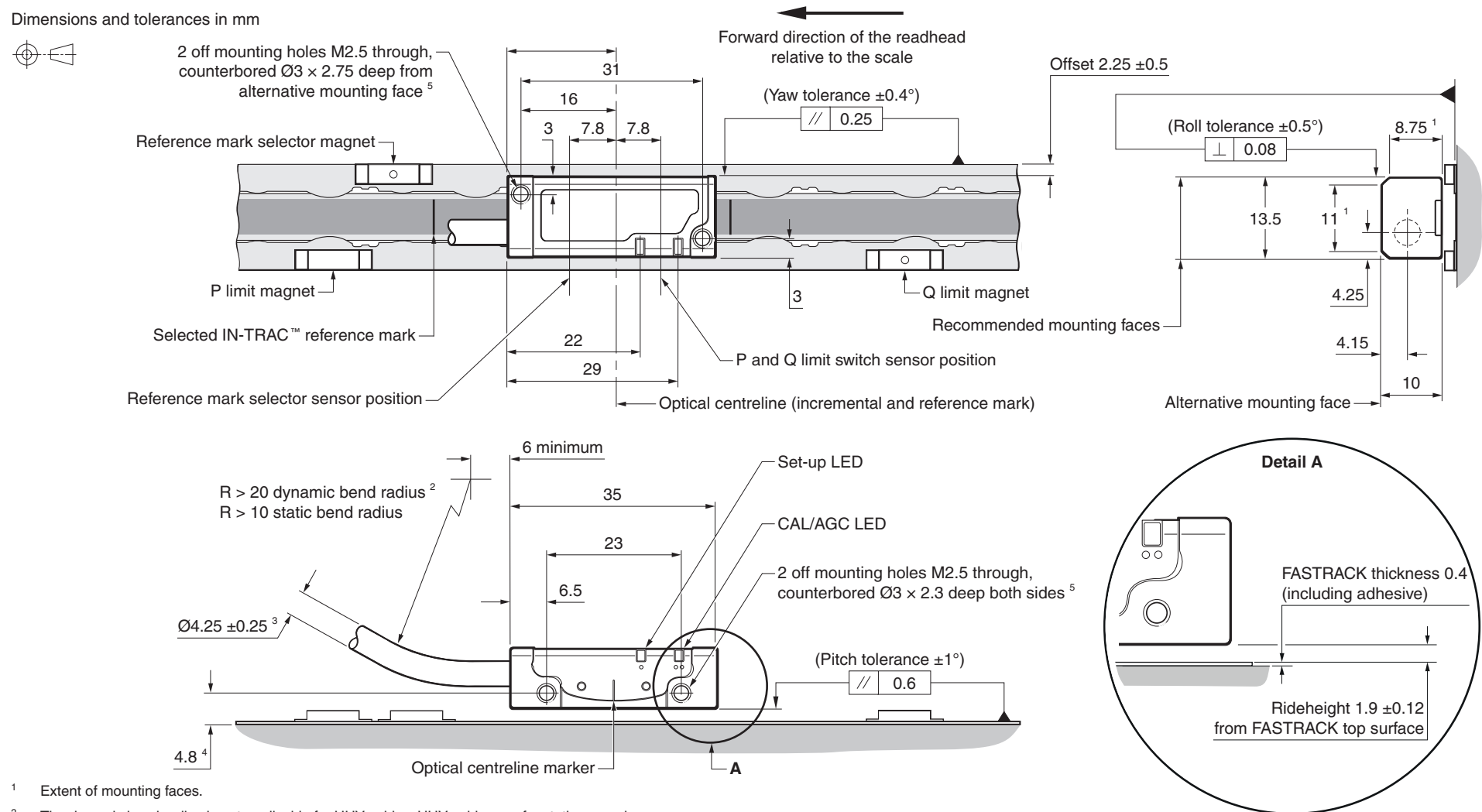

- 1 Extent of mounting faces.
- 2 The dynamic bend radius is not applicable for UHV cables. UHV cables are for static use only.
- 3 The UHV cable diameter is approximately 3 mm.
- 4 Dimension from substrate.
- 5 The recommended thread engagement is 5 mm minimum (7.5 mm including counterbore) and the recommended tightening torque is 0.25 Nm to 0.4 Nm.

Ti/TD interface drawing

Dimensions and tolerances in mm

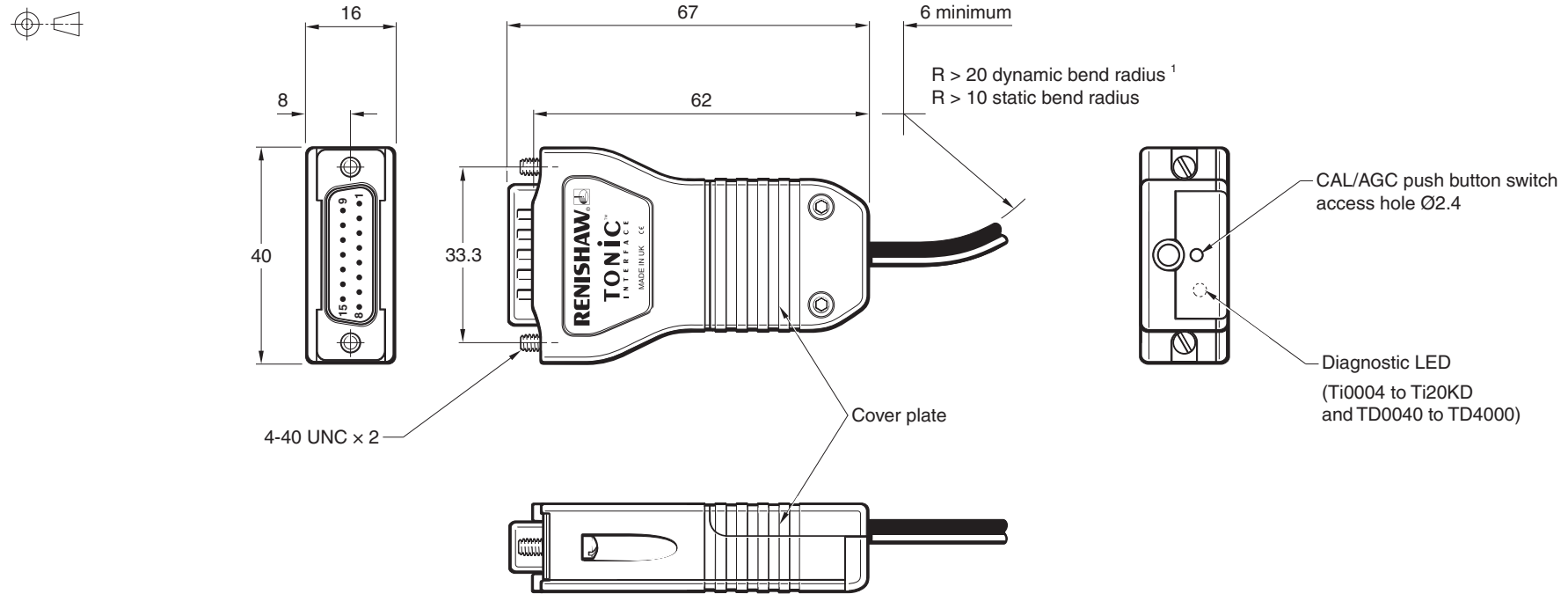

CAL button operation

Function	Operation
Calibration (CAL) routine enable/disable	Push and release (< 3 seconds)
Automatic Gain Control (AGC) enable/disable	Push and release (> 3 seconds)
Restore factory defaults	Push and hold during power 'Off/On' cycle

NOTES:

- For full readhead and interface LED diagnostics, see 'System LEDs' on page 28.
- Only the readhead is UHV compatible. The Ti/TD interface must be kept outside of the vacuum chamber.

¹ The dynamic bend radius is not applicable for UHV cables. UHV cables are for static use only.

DOP interface drawing

Dimensions and tolerances in mm

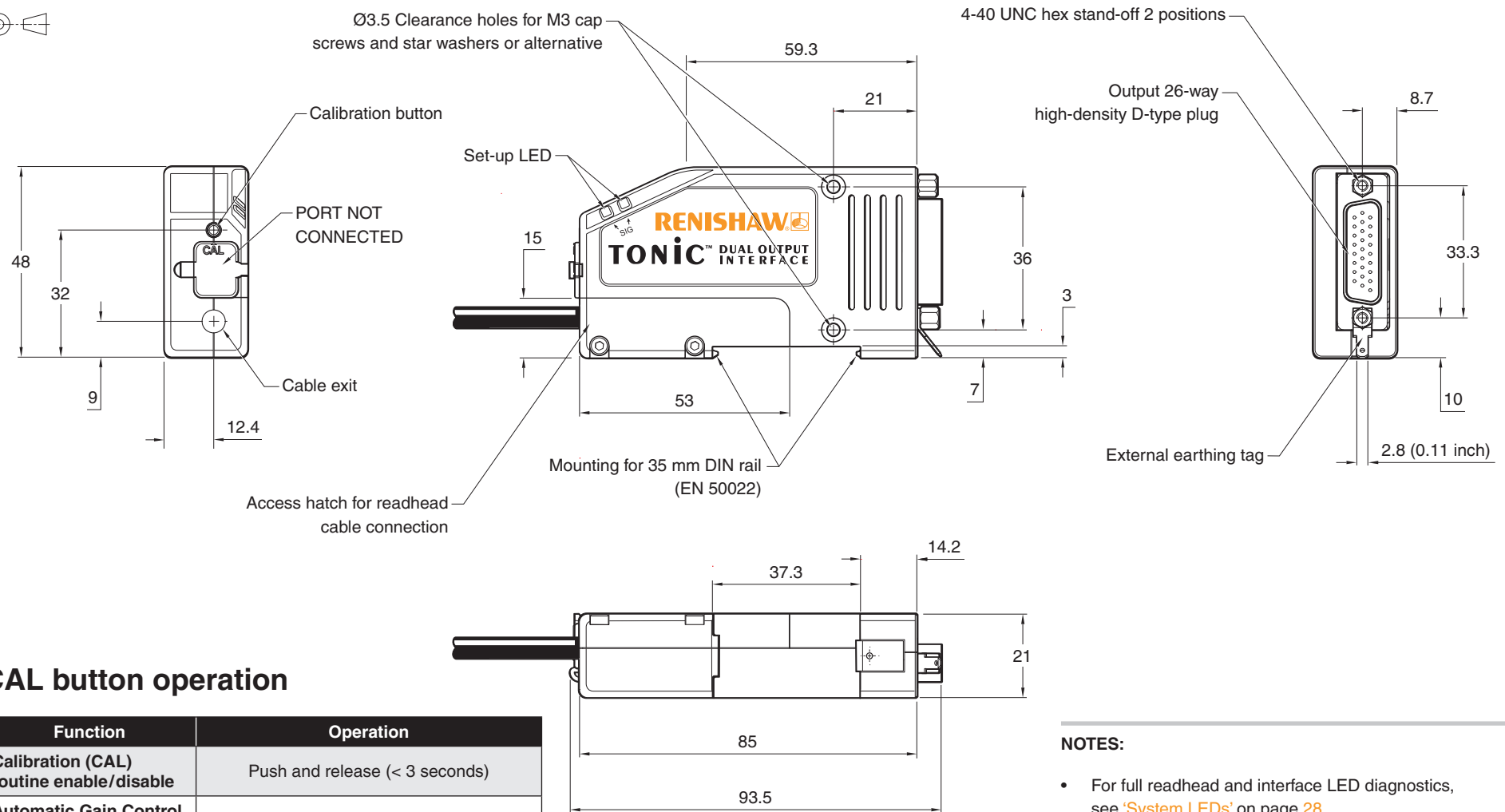

CAL button operation

Function	Operation
Calibration (CAL) routine enable/disable	Push and release (< 3 seconds)
Automatic Gain Control (AGC) enable/disable	Push and release (> 3 seconds)
Restore factory defaults	Push and hold during power 'Off/On' cycle

NOTES:

- For full readhead and interface LED diagnostics, see 'System LEDs' on page 28.
- Only the readhead is UHV compatible. The DOP interface must be kept outside of the vacuum chamber.

RTL20/FASTRACK system installation drawing

Dimensions and tolerances in mm

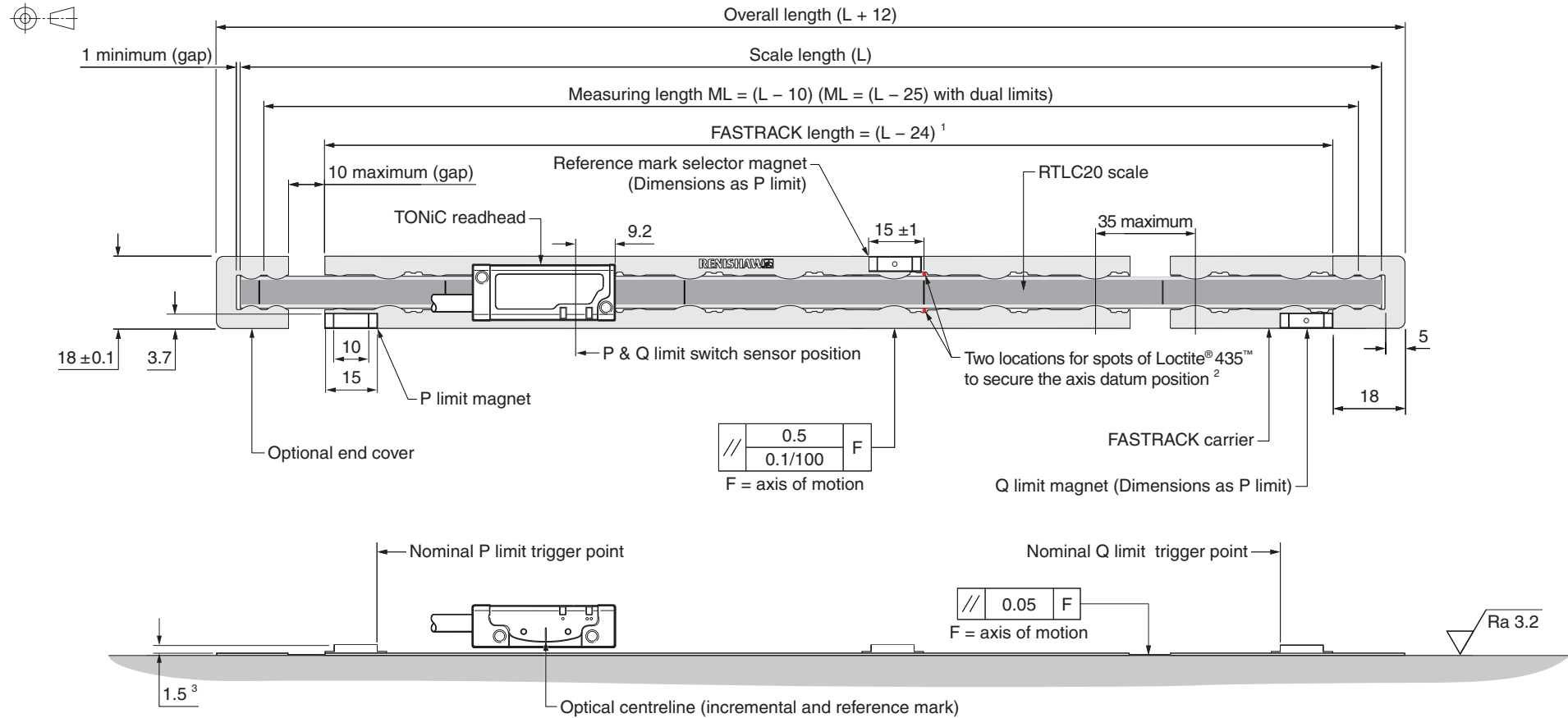

NOTES:

- The minimum recommended FASTRACK carrier length is 100 mm.
- The reference mark selector and limit actuator locations are correct for the readhead orientation shown.
- External magnetic fields greater than 6 mT, in the vicinity of the readhead, may cause false activation of the limit and reference sensors.

¹ Assumes a 1 mm gap between the scale and the end covers and a zero gap between the FASTRACK carrier and the end covers.

² For alternative mechanical datum clamp methods, see 'Mechanical clamp' on page 20.

³ Dimension from the FASTRACK carrier surface.

Equipment required for installing the RTALC20 scale and the FASTRACK carrier

Required parts:

- Appropriate length of RTALC20 scale
(see 'RTALC20/FASTRACK system installation drawing' on page 14)
- Appropriate length of FASTRACK carrier
(see 'RTALC20/FASTRACK system installation drawing' on page 14)
- Loctite® 435™ (P-AD03-0012) or bolted datum clamp (A-9589-0077) ¹
- Appropriate cleaning solvents (see 'Storage and handling' on page 9)
- FASTRACK carrier centre section removal tool (A-9589-0122)
- Small pair of pliers
- Dial test indicator (DTi)
- Protective gloves

Optional parts:

- A pair of scale end covers (A-9589-0058)
- Renishaw scale wipes (A-9523-4040)
- Lint-free cloth
- Loctite 435 dispensing tip (P-TL50-0209)
- RTAL scale installation tool (A-9589-0420)
- Reference mark selector magnet (A-9653-0143) ²
- Q limit magnet (A-9653-0139)
- P limit magnet (A-9653-0138)
- Magnet applicator tool (A-9653-0201)
- Guillotine (A-9589-0071) or shears (A-9589-0133) for cutting RTALC20 scale and FASTRACK carrier to length required

¹ Used to secure the axis datum position.

² The reference mark selector magnet is only required for 'Customer selectable reference mark' readheads.

Cutting the RTALC20 scale and the FASTRACK carrier

CAUTION: During handling or installation of the FASTRACK carrier, suitable gloves should be worn to protect against injury from sharp edges.

If required cut the FASTRACK carrier and the RTALC20 scale to length (separately) using the guillotine or the shears after referring to the installation drawing. Refer to the '[RTALC20/FASTRACK system installation drawing](#)' on page 14.

Using the guillotine

The guillotine should be held securely in place, using a suitable vice or clamping method.

Once secured, feed the FASTRACK carrier or the RTALC20 scale through the guillotine as shown, and place the guillotine press block down onto the FASTRACK/scale.

NOTE: Ensure the block is in the correct orientation (as shown below).

Whilst holding the block in place, in a smooth motion, pull down the lever to cut through the FASTRACK/scale.

Guillotine press block orientation when cutting the FASTRACK carrier

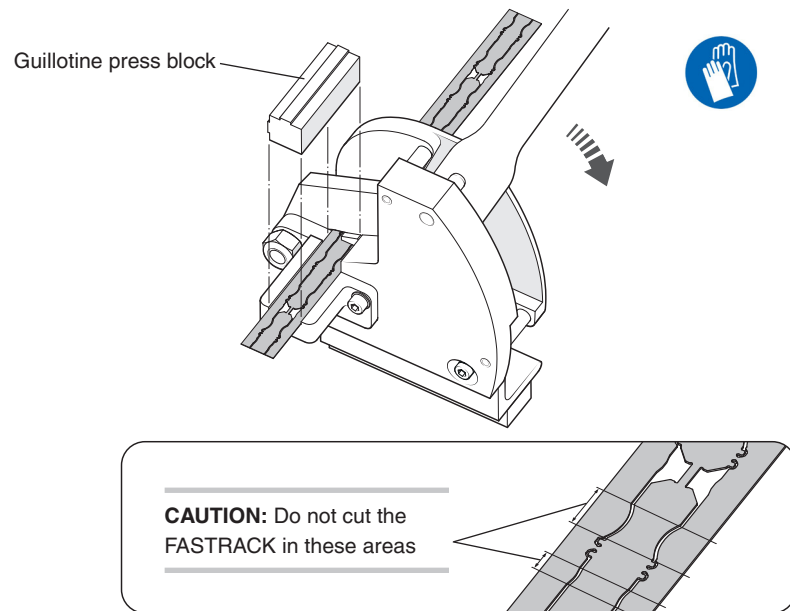

Guillotine press block orientation when cutting the RTALC20 scale

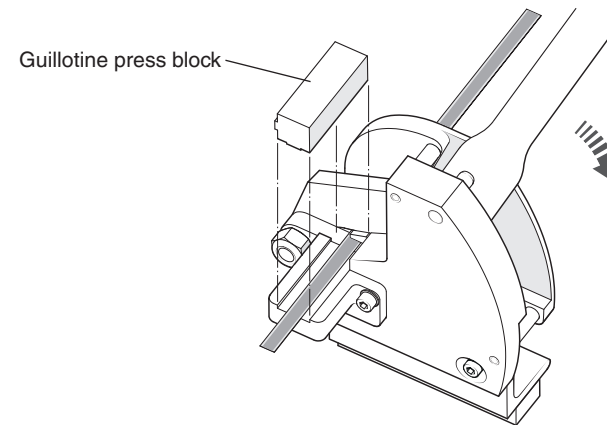

Using the shears

Feed the FASTRACK carrier or the RTALC20 scale through the appropriately sized aperture on the shears (as shown below).

Hold the scale in place and close the shears in a smooth motion to cut through the scale.

Insertion of the FASTRACK carrier through the widest aperture

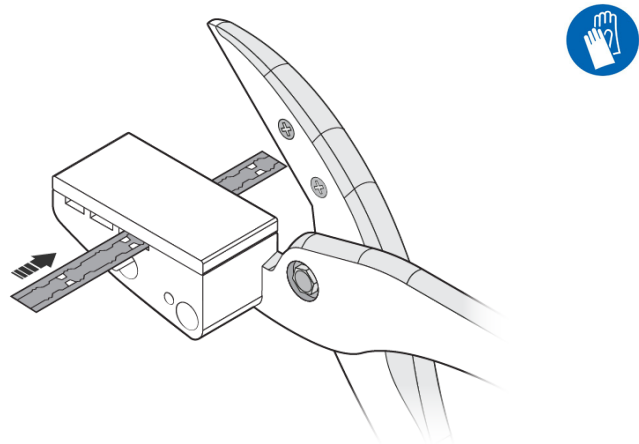

Insertion of the RTALC20 scale through the middle aperture

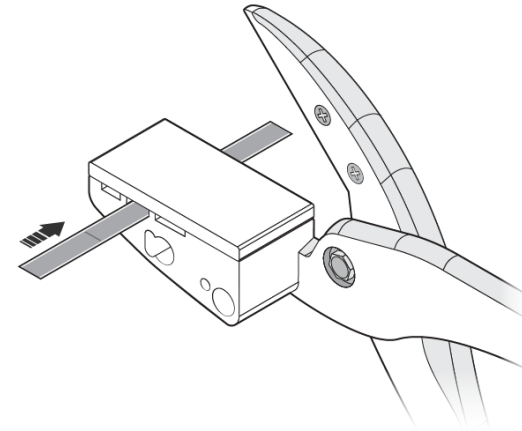

CAUTION: Do not cut
FASTRACK in these areas

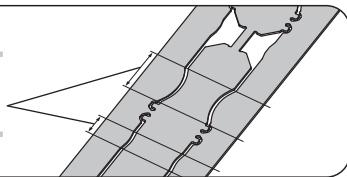

Applying the RTALC20 and FASTRACK scale system

1. Thoroughly clean and degrease the substrate and allow it to dry.

For FASTRACK carrier location a ledge, separate straight edge(s), or dowels can be used.

2. Check the alignment of the ledge/separate straight edge(s) with respect to the axis of motion (see 'RTALC20/FASTRACK system installation drawing' on page 14).

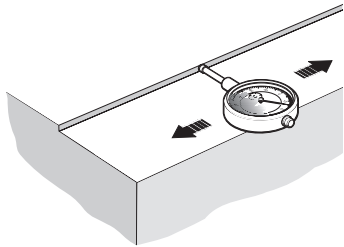

3. Before sticking the FASTRACK carrier to the substrate, bend the centre section upwards slightly using a small pair of pliers.

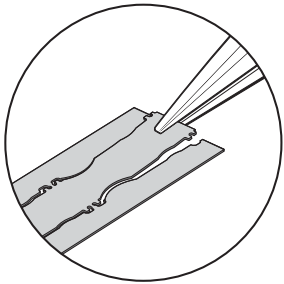

4. Remove the backing liner and stick the FASTRACK carrier to the substrate locating it against the ledge/separate straight edge(s) or dowels.

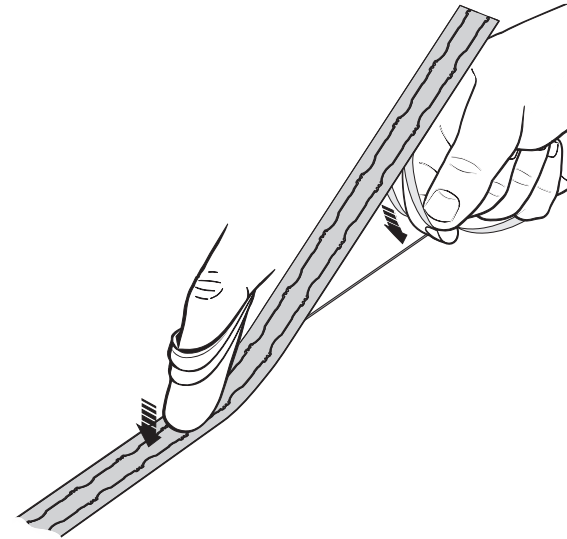

Ensure complete adhesion to the substrate by applying firm finger pressure along the length of the FASTRACK from the centre outwards towards each end using a lint-free cloth.

NOTE: Allow the FASTRACK a minimum of 20 minutes to adhere before removing the centre section.

- Engage the centre section removal tool and, with a consistent forward pressure, remove the centre section of the FASTRACK carrier.

If the ledge method or similar is used then the appropriate side panel on the removal tool will need to be removed as shown below.

IMPORTANT: Wear suitable protective gloves whilst carrying out this procedure to avoid risk of cuts.

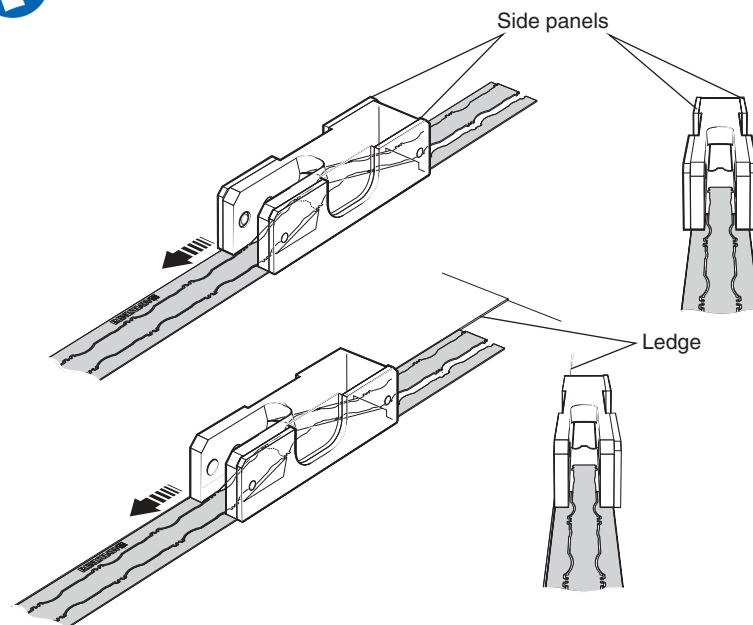

- Slide the RTLC20 scale into the FASTRACK carrier ensuring the scale is fed under the projections as shown below.

The RTLC20 scale can be installed manually by either pulling or pushing it through the FASTRACK carrier.

Alternatively, use the optional RTL scale installation tool as shown below.

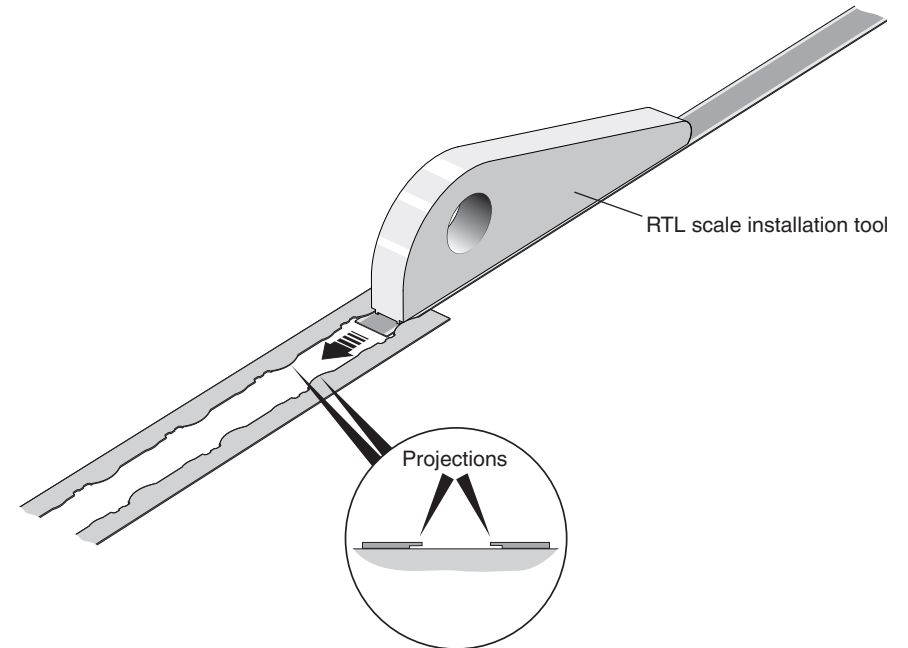

NOTE: For instructions on how to use the scale installation tool, download the *RTL* scale installation tool* user guide (Renishaw part no. M-9589-9101) from the website at www.renishaw.com/tonicdownloads.

IMPORTANT: If manually installing the scale using fingers, suitable gloves should be worn to protect against injury from sharp edges.



7. Scale datum

The datum clamp fixes the RTALC20 scale rigidly to the substrate at the location chosen.

The metrology of the system may be compromised if the datum clamp is not used.

The datum clamp does not need to be fitted adjacent to a reference mark. It can be positioned anywhere along the axis, depending upon the customer's requirements.

NOTE: When the reference mark and the datum clamp are aligned as shown below, the reference output will be positionally repeatable with respect to the substrate.

Adhesive clamp

Using dispensing tip apply Loctite 435 between scale and FASTRACK so it wicks underneath adjacent to the user selected datum location as shown.

NOTES: The drawing shows the scale datum adjacent to the chosen reference mark.

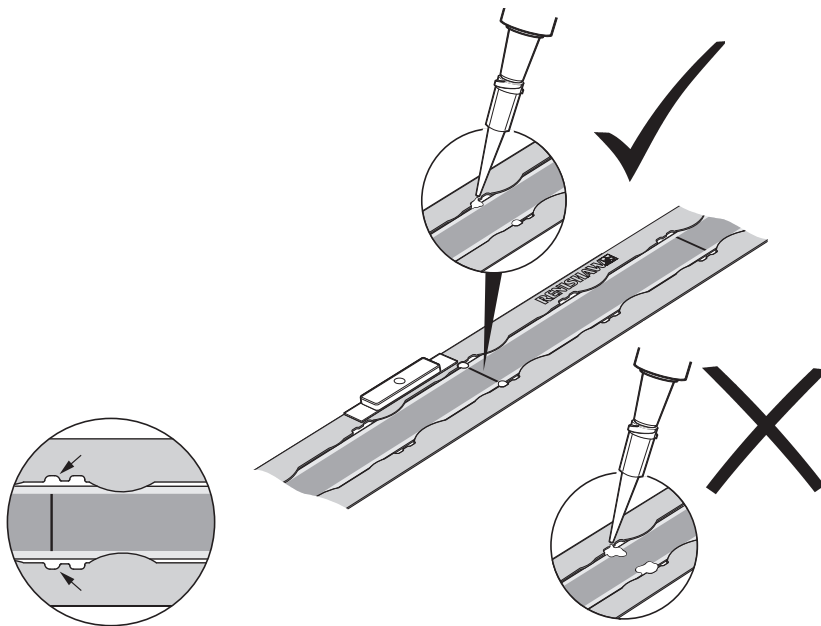

NOTE: Only apply Loctite 435 in these gaps to ensure the best bond. Loctite 435 will wick under the scale to lock it to the substrate.

Mechanical clamp

Dimensions and tolerances in mm

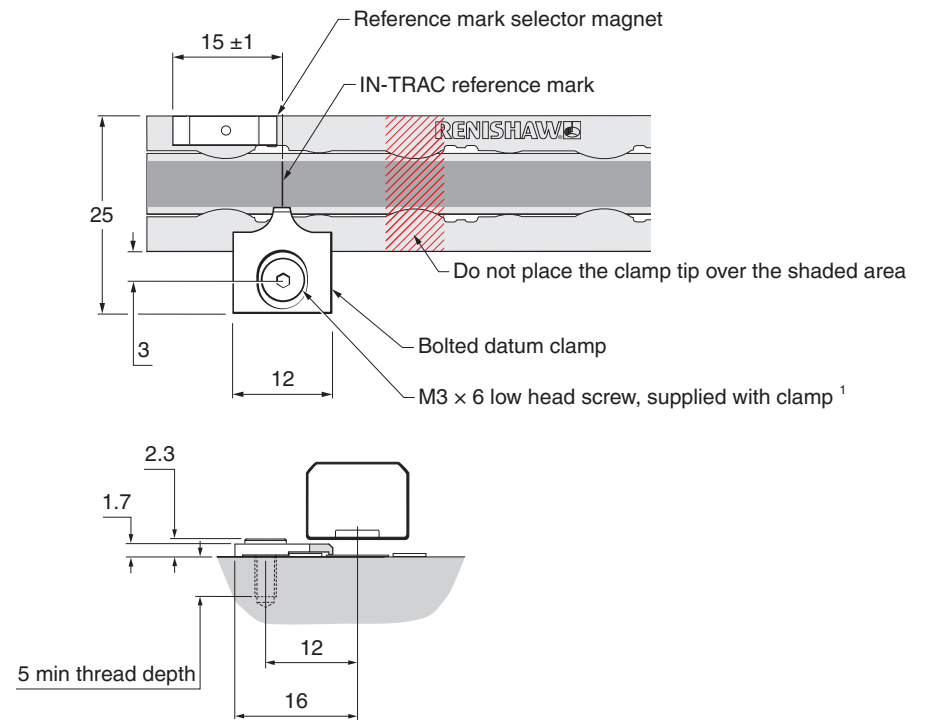

¹ Additional screws available (pack of 25, A-9584-2047).

8. Optional: fix the self-adhesive end covers ensuring a gap of at least 1 mm between the end of the scale and the end cover.

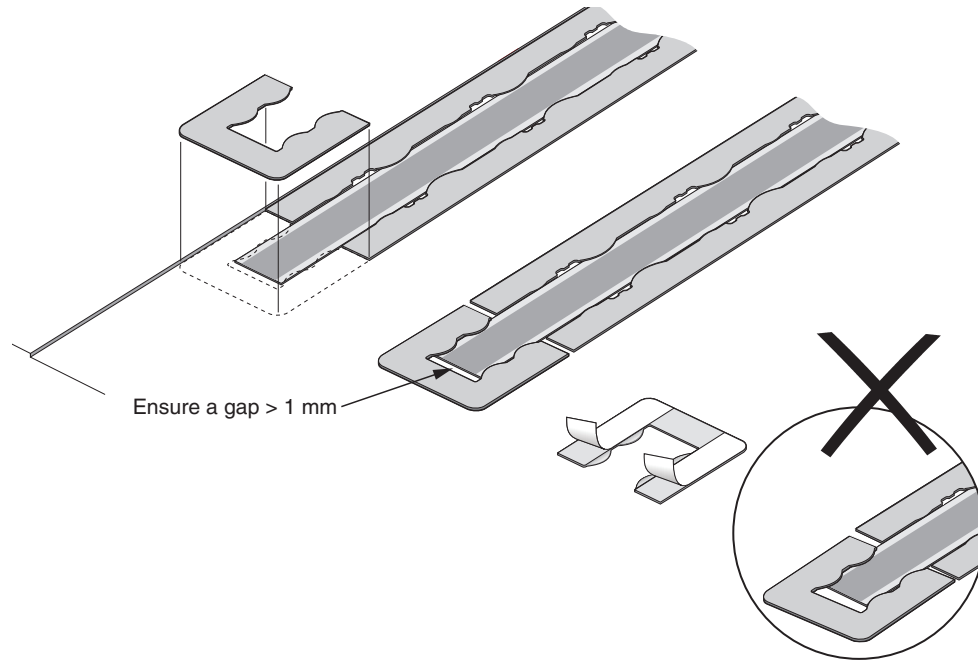

9. Clean the FASTRACK carrier and the RTALC20 scale using a lint-free cloth.

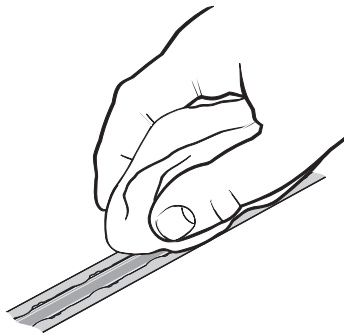

Reference mark selector and limit magnet installation

IMPORTANT: Allow 24 hours after the scale application before fitting the magnets.

As the readhead passes the reference mark selector magnet or limit switch magnet, a force of up to 0.2 N is generated between the magnet and the concentrators on the readhead.

- The design of the bracket should be sufficiently stiff so that it is able to tolerate such force without distorting.
- Following the datum clamping instructions in step 7 of the scale installation will prevent this magnetic force from disturbing the scale (see page 20).

Use the applicator tool to position the reference mark selector and limit magnets accurately and easily.

1. Attach the magnet to the applicator tool as shown.
2. Remove the self-adhesive backing paper from the magnet.

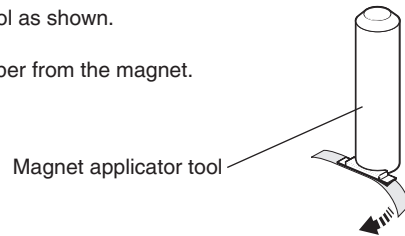

3. Place the magnet in the chosen location alongside the outer edge of the FASTRACK ensuring that it is not mounted on the scale.

- Limit magnets can be positioned at any user defined location along the axis length.
- Position the reference mark selector magnet adjacent to the selected IN-TRAC reference mark as shown.¹

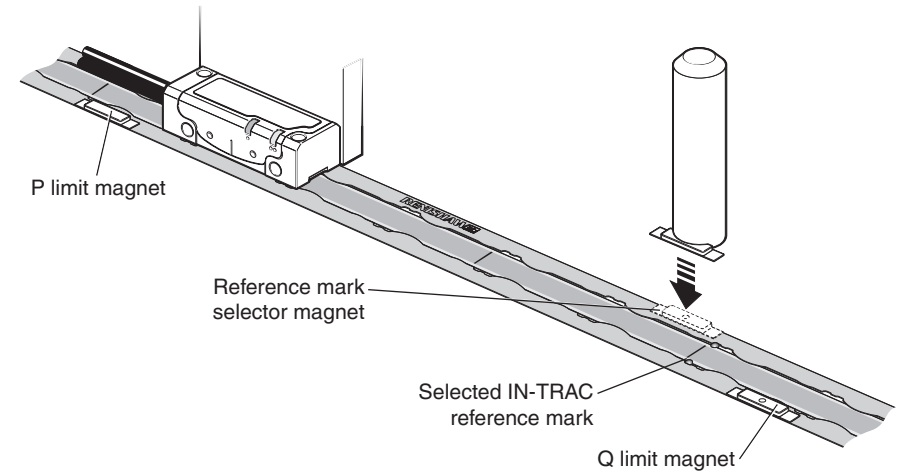

NOTES:

- The limit output is nominally asserted when the readhead limit switch sensor passes the limit magnet leading edge, but can trigger up to 3 mm before that edge (see 'RTL20/FASTRACK system installation drawing' on page 14).
- The reference and limit magnets may creep when influenced by magnetic materials in close proximity. In such cases, use an additional fillet of epoxy glue or similar along the outer edge of the magnet assembly to hold them in place.
- External magnetic fields greater than 6 mT, in the vicinity of the readhead, may cause false activation of the limit and reference sensors.

NOTE: The reference mark selector and limit actuator locations are correct for the readhead orientation shown.

4. Press the magnet down firmly using a clean, dry, lint-free cloth for complete adhesion.

¹ The reference mark selector magnet is only required for 'Customer selectable reference mark' readheads. For more information refer to TONiC™ encoder system data sheet (Renishaw part no. L-9517-9337).

TONiC quick-start guide

This section is a quick-start guide to installing a TONiC system. More detailed information on installing the system is contained on pages 24 to page 31 of this installation guide.

INSTALLATION

Ensure the scale, readhead optical window and mounting faces are clean and free from obstructions.



If required, ensure that the reference mark selector magnet is correctly positioned (see 'RTLC20/FASTRACK system installation drawing' on page 14).



Plug the readhead cable into the Ti, TD or DOP interface under the cover plate and reassemble the interface (see 'System connection - Ti or TD interfaces' on page 24 or 'System connection - DOP interface' on page 26).

Connect to the receiving electronics and power-up.



Ensure AGC is switched off; the CAL LED on the readhead should be off (if not press and hold the CAL button on the interface until the CAL LED on the readhead switches off).



Install and align the readhead to maximise signal strength over the full axis of travel as indicated by the readhead and interface set-up LEDs (readhead - green; interface - ideally blue/purple).¹

CALIBRATION

Press and release the CAL button on the interface.
The CAL LED on the readhead will be single flashing.



Move the readhead along the scale at slow speed (< 100 mm/s), without passing a reference mark, until the LED starts double-flashing.



No reference mark

If a reference mark is not being used, the calibration routine should now be exited by pressing and releasing the CAL button. The CAL LED will stop flashing. (Incremental CAL values are automatically stored)



Reference mark

Move the readhead back and forth over the selected reference mark until the CAL LED stops flashing and remains 'off'. (Incremental and reference mark CAL values are automatically stored)



The system is now calibrated and ready for use. AGC can now be switched on if required by pressing and holding the CAL button until the CAL LED on the readhead switches on.

CAL values and AGC status are stored in the TONiC readheads non-volatile memory at power down.

NOTE: If calibration fails, restore factory defaults (see 'Restoring factory defaults' on page 31) and repeat the installation and calibration routine.

¹ Analogue Ti interfaces do not have a set-up LED.

System connection - Ti or TD interfaces

Approved ESD precautions must be followed at all times during readhead and interface electrical connections.

The readhead is connected to the Ti or TD interface via a small, rugged connector to allow for easy feed-through during installation.

Connecting the readhead

- Remove the cover plate as shown (2 × M2.5 hex head screws).

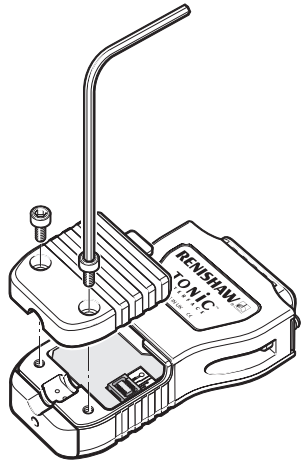

- Taking care not to touch the pins, plug the connector into the socket in the interface, ensuring correct orientation as shown.

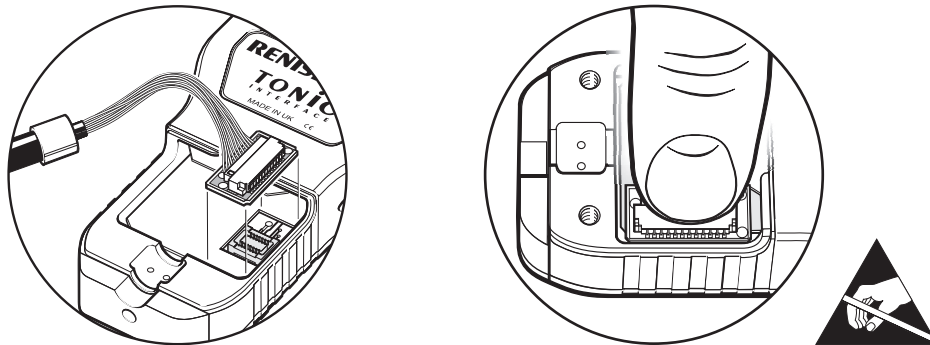

- Refit the cover plate ensuring the cable ferrule is located in the recess on the inside and no wires are trapped under the cover plate.

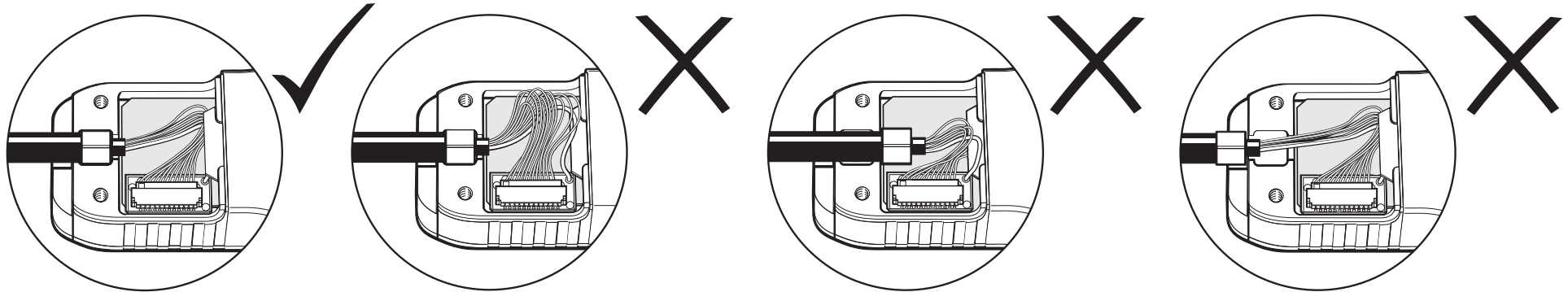

Disconnecting the readhead

- Remove the cover plate on the interface (2 × M2.5 hex head screws).
- Gently lever the connector PCB (on the end of the cable) out of the socket. Do not pull the cable to remove the connector.

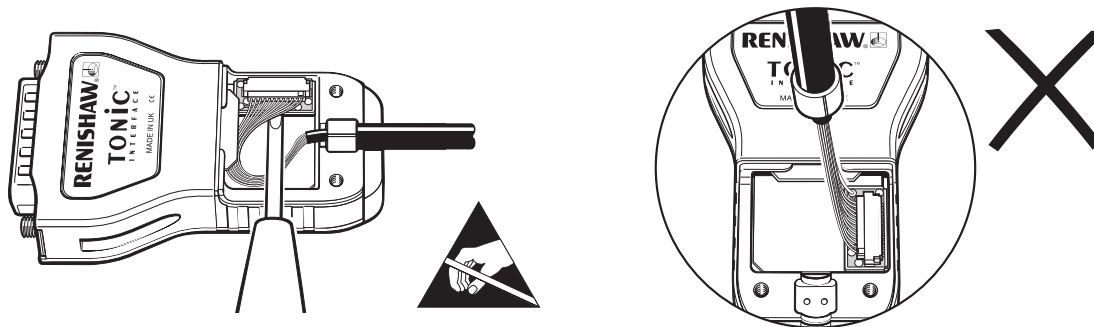

- Place the connector in an anti-static bag.
- Refit the cover plate.

System connection - DOP interface

Approved ESD precautions must be followed at all times during readhead and interface electrical connections.

The readhead is connected to the DOP interface via a small, rugged connector to allow for easy feed-through during installation.

Connecting the readhead

1. Remove the cover plate as shown (2 M2.5 hex head screws).
2. Taking care not to touch the pins, plug the connector into the socket in the interface, ensuring correct orientation as shown.
3. Refit the cover plate ensuring the cable ferrule is located in the recess on the inside and no wires are trapped under the cover plate.

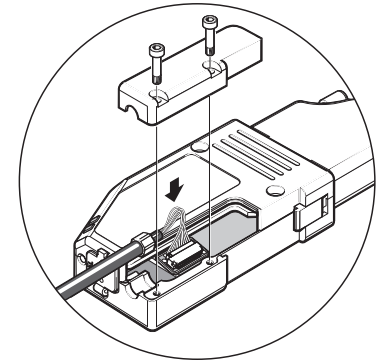

DOP interface mounting

The DOP interface can be DIN rail mounted or mounted to a suitable surface using customer-supplied screws.

NOTES:

- The recommended screw type M3 × 0.5 and must comply with: ISO 4762/DIN 912 grade 8.8 minimum/ANSI B18.3.1M.
- No washer is required under the screw head.
- The minimum thread engagement is 6 mm.
- The tightening torque should be between 0.9 Nm and 1.1 Nm.
- The DIN rail mounting, where used, must comply with EN 50022.

Disconnecting the readhead

1. Remove the cover plate on the interface (2 M2.5 hex head screws).
2. Gently lever the connector PCB (on the end of the cable) out of the socket. Do not pull the cable to remove the connector.
3. Place the connector in an anti-static bag.
4. Refit the cover plate.

Readhead mounting and alignment

Mounting brackets

The bracket must have a flat mounting surface and should provide adjustment to enable conformance to the installation tolerances, allow adjustment to the rideheight of the readhead, and be sufficiently stiff to prevent deflection or vibration of the readhead during operation.

Readhead set-up

Ensure that the scale, readhead optical window and mounting face are clean and free from obstructions.

NOTE: When cleaning the readhead and the scale apply the cleaning fluid sparingly, do not soak.

1. Mount the readhead to the bracket using 2 M2.5 screws.
2. To set the nominal rideheight, place the green spacer with the aperture under the optical centre of the readhead to allow normal LED function during set-up procedure.
3. Adjust the readhead to maximise the signal strength and achieve a green set-up LED on the readhead (> 70% signal) and a blue LED on the interface ¹ along the full axis of travel.

NOTE: The readhead should be installed and set-up with the AGC switched off (CAL LED off). When reinstalling the readhead the factory defaults should be restored (see 'Restoring factory defaults' on page 31).

Readhead set-up LED status



NOTE: For full readhead and interface LED diagnostics, see 'System LEDs' on page 28.

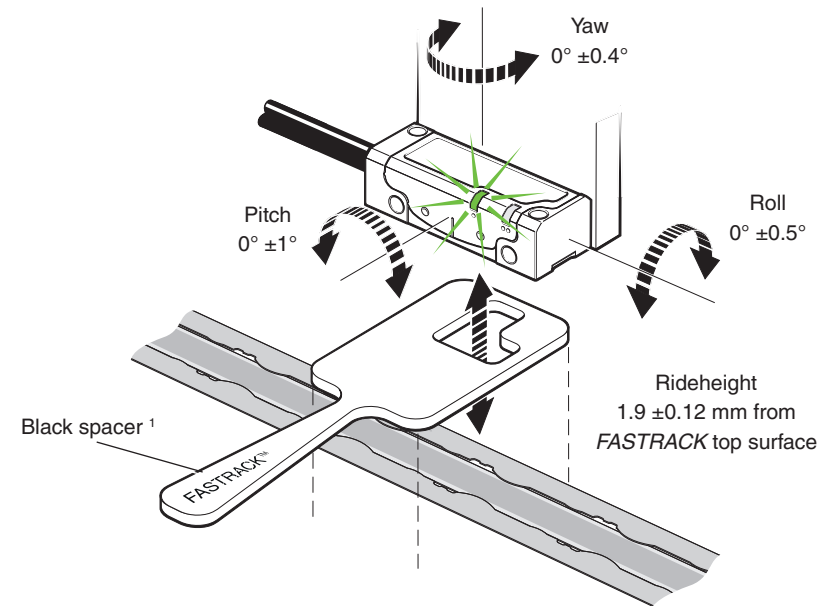

Interface set-up LED status ²



Ti or TD interface LED

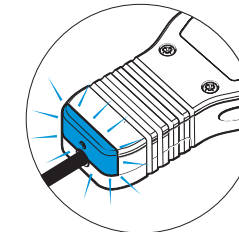

DOP interface LEDs

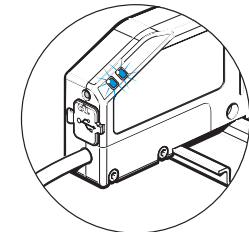

¹ Use only the black spacer provided.

² Analogue Ti interfaces do not have a set-up LED.

System LEDs

TONiC readhead LED diagnostics

LED		Indication	Status
Set-up	Incremental	Green	Normal set-up; signal level > 70%
		Orange	Acceptable set-up; signal level 50% to 70%
		Red	Poor set-up; signal may be too low for reliable operation; signal level < 50%
	Reference mark	Green (flash) ¹	Normal phasing
		Orange (flash)	Acceptable phasing
		Red (flash)	Poor phasing; clean scale and recalibrate if required
CAL	Operating	On	Automatic Gain Control – On
		Off	Automatic Gain Control – Off
	Calibration	Single-flashing	Calibrating incremental signals
		Double-flashing	Calibrating reference mark
	Reset	Flashing at power-up (< 2s)	Restore factory defaults

¹ The flash will effectively be invisible when passing the reference mark if the incremental signal is > 70%.

² Analogue Ti interfaces do not have a set-up LED.

³ The alarm output will take the form of 3-state or line driven E- signal depending on the interface configuration.

NOTES:

- Momentary status only, while the fault condition remains.
- The alarm may result in an axis position error; re-datum to continue.
- Some Ti interfaces do not output overspeed alarm.

See the product nomenclature for interface configuration in the *TONiC™ encoder system* data sheet (Renishaw part no. L-9517-9337). This can be downloaded from our website at www.renishaw.com/tonicdownloads and is also available from your local Renishaw representative.

Ti, TD or DOP interface LED diagnostics ²

Signal	Indication	Status	Alarm output ³	
Incremental	Purple	Normal setup; signal level 110% to 135%	No	
	Blue	Optimum setup; signal level 90% to 110%	No	
	Green	Normal set-up; signal level 70% to 90%	No	
	Orange	Acceptable set-up; signal level 50% to 70%	No	
	Red	Poor set-up; signal may be too low for reliable operation; signal level < 50%	No	
	Red / blank - flashing	Poor set-up; signal level < 20%; system in error	Yes	
	Blue / blank - flashing	Over speed; system in error	Yes	
	Purple / blank - flashing	Over signal; system in error	Yes	
	Reference mark	Blank flash	Reference mark detected (speed < 100 mm/s only)	No

System calibration

Calibration is an essential operation that completes readhead set-up, with the optimum incremental and reference mark signal settings stored in the readhead's non-volatile memory.

Before system calibration:

1. Ensure the scale and readhead optical window are clean (contamination around the reference mark may result in reference mark dephasing).
2. If reinstalling, restore factory defaults (see '[Restoring factory defaults](#)' on page 31).
3. Ensure Automatic Gain Control is switched off (CAL LED on readhead is not illuminated) before beginning calibration (see '[Switching Automatic Gain Control \(AGC\) on or off](#)' on page 31).
4. Ensure signal strength has been optimised over the full axis of travel; the readhead LED will be green.

NOTES:

- During calibration the speed should not exceed 100 mm/s or the readheads maximum speed, whichever is slowest.
 - The TD interface can be calibrated in either resolution.
-

Incremental signal calibration

1. Press and release the CAL button on the end of the interface (for < 2 seconds) using a 2 mm allen key or similar tool.

Ti or TD interface

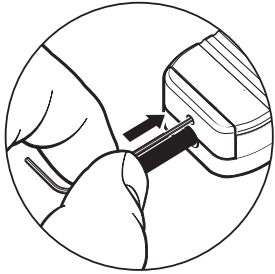

DOP interface

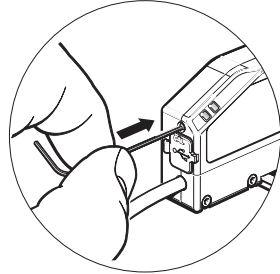

WARNING: Activating the CAL switch only requires 2.5 N force. Applying excess force may permanently damage the switch.

The CAL LED will now periodically single-flash to indicate that it is in incremental signal calibration mode.

2. Move the readhead along the axis, ensuring you do not pass the selected reference mark until the CAL LED starts double-flashing. This indicates the incremental signal is now calibrated and the new settings are stored in the readhead memory.

The system is now ready for reference mark phasing.

3. For systems without a reference mark, exit the calibration routine (see 'Calibration routine – manual exit')
4. If the system does not automatically enter the reference mark phasing stage (no double-flashing of the CAL LED) the calibration of the incremental signals has failed.
 - Ensure failure is not due to overspeed (> 100 mm/s or exceeding the readhead maximum speed),
 - Exit the calibration routine and restore factory defaults (see 'Restoring factory defaults' on page 31).
 - Check the readhead installation and system cleanliness and repeat the calibration routine.

Reference mark phasing

1. Move the readhead back and forth over the selected reference mark until the CAL LED stops flashing and remains off. The reference mark is now phased.

NOTE: Only the chosen reference mark that has been used in the calibration routine is guaranteed to remain phased.

The system automatically exits the CAL routine and is ready for operation.

2. If the CAL LED continues double-flashing after passing the chosen reference mark many times, it is not detecting the reference mark.
 - Ensure that the correct readhead configuration is being used. Readheads can either output all reference marks or only output a reference mark where a reference selector magnet is fitted depending on the options chosen when ordering.
 - Check the reference mark selector magnet is fitted in the correct location relative to readhead orientation (see 'RTL20/FASTRACK system installation drawing' on page 14).

Calibration routine – manual exit

1. To exit the calibration routine at any stage press the CAL button. The CAL button will stop flashing.

LED status during system calibration

CAL LED	Settings stored
Single flashing	None, restore factory defaults and recalibrate
Double flashing	Incremental only
Off (auto-complete)	Incremental and reference mark

Restoring factory defaults

When realigning the readhead, reinstalling the system, or in the case of continued calibration failure, factory defaults must be restored.

To restore factory defaults:

- Switch system off.
- Press and hold the CAL button whilst switching the system on. The CAL LED on the readhead will flash several times, indicating that the factory defaults have been restored.
- Release the CAL button.
- Check the '[Readhead mounting and alignment](#)' on page 27 and recalibrate the system (see '[System calibration](#)' on page 29).

NOTE: System must be re-calibrated after restoring factory defaults.

Switching Automatic Gain Control (AGC) on or off

The AGC can be switched on or off via the interface.

- Press and hold the CAL button on the interface for > 3 seconds to switch AGC on or off. The CAL LED on the readhead will be illuminated when AGC is active.

NOTE: The system must be calibrated before switching AGC on (see '[System calibration](#)' on page 29).

Output signals

Analogue outputs

Readhead output

Function	Output type		Signal		Colour
Power	-		5 V Power		Brown
			0 V Power		White
Incremental signals	Analogue	Cosine	V_1	+	Red
				-	Blue
		Sine	V_2	+	Yellow
				-	Green
Reference mark	Analogue		V_0	+	Violet
				-	Grey
Limits	Open collector		V_p		Pink
			V_q		Black
Set-up	-		V_x		Clear
Calibrate	-		CAL		Orange
Shield	-		Inner shield ¹		Green/Yellow
	-		Outer shield		Outer screen

Interface output (analogue Ti0000 only)

Function	Output type		Signal		Pin
Power	-		5 V Power		4
			5 V Sense		5
			0 V Power		12
			0 V Sense		13
Incremental signals	Analogue	Cosine	V_1	+	9
				-	1
		Sine	V_2	+	10
				-	2
Reference mark	Analogue		V_0	+	3
				-	11
Limits	Open collector		V_p		7
			V_q		8
Set-up	-		V_x		6
Calibrate	-		CAL		14
Shield	-		Inner shield		Not connected
	-		Outer shield		Case

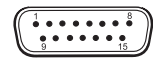

15 way D-type plug

¹ There is no inner shield on UHV cables.

Digital outputs

Interface output (digital Ti0004 to Ti20KD and TD4000 to TD0040)

Function	Output type	Signal		Interface	
				Ti0004 - Ti20KD	TD4000 - TD0040
				Pin	Pin
Power	-	5 V		7, 8	7, 8
		0 V		2, 9	2, 9
Incremental	RS422A digital	A	+	14	14
			-	6	6
		B	+	13	13
			-	5	5
Reference mark	RS422A digital	Z	+	12	12
			-	4	4
Limits	Open collector	P ¹		11	-
		Q		10	-
Set-up	RS422A digital	X		1	1
Alarm ²	-	E	+	-	11
			-	3	3
Resolution switching ³	-	-		-	10
Shield	-	Inner shield		-	-
	-	Outer shield		Case	Case



15-way D-type plug

¹ Becomes alarm (E+) for Ti options E, F, G, H.

² The alarm signal can be output as a line driver signal or 3-state. Select the preferred option at time of ordering.

³ On TD interfaces pin 10 should be connected to 0 V to switch to lower resolution.

DOP interface output

Function	Output type	Signal	Pin		
Power	-	5 V Power	26		
		5 V Sense	18		
		0 V Power	9		
		0 V Sense	8		
Incremental signals	RS422A digital	A	+	24	
			-	6	
		B	+	7	
			-	16	
	Analogue	Cosine	V_1	+	1
				-	19
		Sine	V_2	+	2
				-	11
Reference mark	RS422A digital	Z	+	15	
			-	23	
	Analogue	V_0	+	12	
			-	20	
Alarm	RS422A digital	E	+	25	
			-	17	
Limits	Open collector	P	4		
		Q	13		
Readhead set-up	-	X	10		
Shield	-	Inner shield	Not connected		
	-	Outer shield	Case		

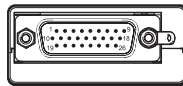

26-way high-density D-type plug

Speed

Clocked output option (MHz)	Maximum speed (m/s)										
	Ti0004 and DOP0004 5 µm	Ti0020 and DOP0020 1 µm	Ti0040 and DOP0040 0.5 µm	Ti0100 and DOP100 0.2 µm	Ti0200 and DOP0200 0.1 µm	Ti0400 and DOP0400 50 nm	Ti1000 and DOP1000 20 nm	Ti2000 and DOP2000 10 nm	Ti4000 and DOP4000 5 nm	Ti10KD and DOP10KD 2 nm	Ti20KD and DOP20KD 1 nm
50	10	10	10	6.48	3.24	1.62	0.648	0.324	0.162	0.0654	0.032
40	10	10	10	5.40	2.70	1.35	0.540	0.270	0.135	0.054	0.027
25	10	10	8.10	3.24	1.62	0.810	0.324	0.162	0.081	0.032	0.016
20	10	10	6.75	2.70	1.35	0.675	0.270	0.135	0.068	0.027	0.013
12	10	9	4.50	1.80	0.900	0.450	0.180	0.090	0.045	0.018	0.009
10	10	8.10	4.05	1.62	0.810	0.405	0.162	0.081	0.041	0.016	0.0081
08	10	6.48	3.24	1.29	0.648	0.324	0.130	0.065	0.032	0.013	0.0065
06	10	4.50	2.25	0.90	0.450	0.225	0.090	0.045	0.023	0.009	0.0045
04	10	3.37	1.68	0.67	0.338	0.169	0.068	0.034	0.017	0.0068	0.0034
01	4.2	0.84	0.42	0.16	0.084	0.042	0.017	0.008	0.004	0.0017	0.0008
Analogue output (Ti0000)	10 (-3dB)										

NOTE: TD interface maximum speeds are resolution dependent as defined above.

Electrical connections

Grounding and shielding - standard TONiC system

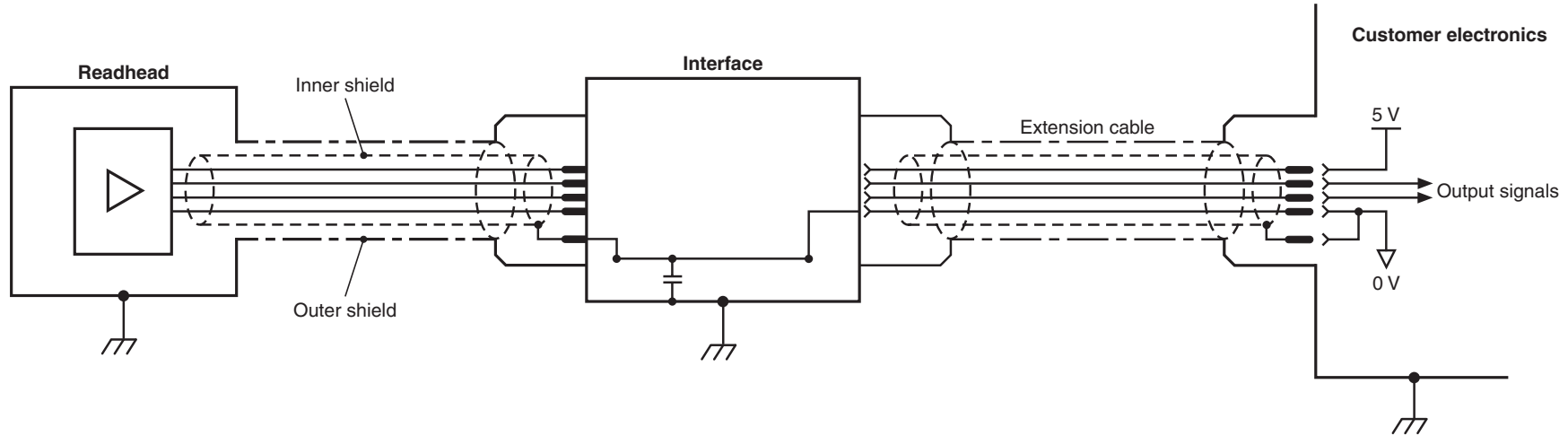

IMPORTANT: The outer shield should be connected to the machine earth (Field Ground). The inner shield should be connected to 0 V at the receiving electronics only. Care should be taken to ensure that the inner and outer shields are insulated from each other. If the inner and outer shields are connected together, this will cause a short between 0 V and earth, which could cause electrical noise issues.

NOTES:

- The maximum cable length between the readhead and the interface is 10 m
- The maximum extension cable is dependent on the cable type, the readhead cable length and the clock speed. Contact your local Renishaw representative for more information.
- For DOP interfaces the external earthing tag on the interface must be used when mounting the interface on a DIN rail.

Grounding and shielding - Ultra-high vacuum (UHV) TONiC system

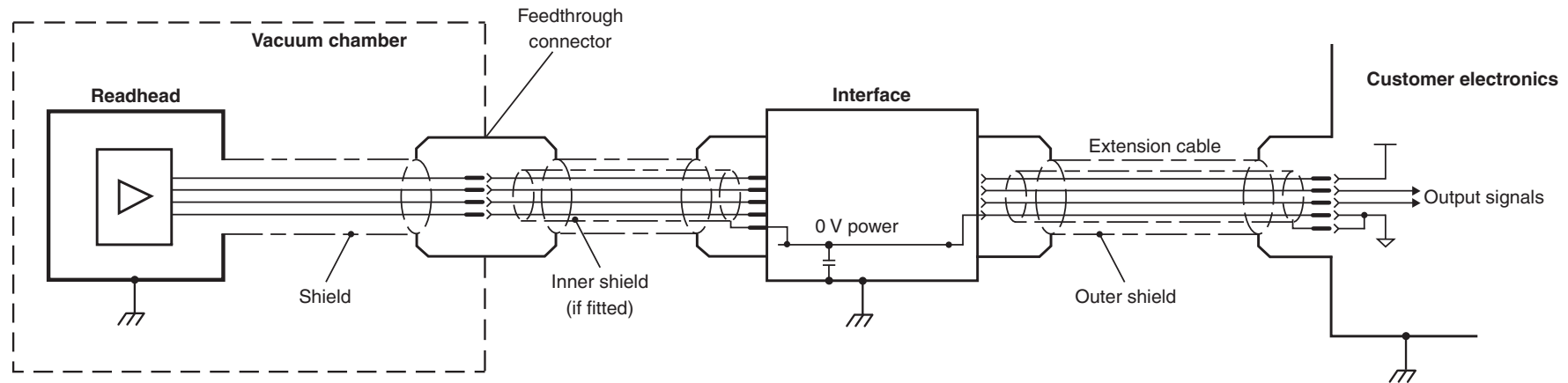

IMPORTANT: The outer shield should be connected to the machine earth (Field Ground). The inner shield should be connected to 0 V at receiving electronics only. Care should be taken to ensure that the inner and outer shields are insulated from each other. If the inner and outer shields are connected together, this will cause a short between 0 V and earth, which could cause electrical noise issues.

NOTES:

- The maximum cable length between the readhead and the interface is 10 m
- The maximum extension cable is dependent on the cable type, the readhead cable length and the clock speed. Contact your local Renishaw representative for more information.
- For DOP interfaces the external earthing tag on the interface must be used when mounting the interface on a DIN rail.

Recommended signal termination

Ti digital, TD and DOP interfaces only ¹

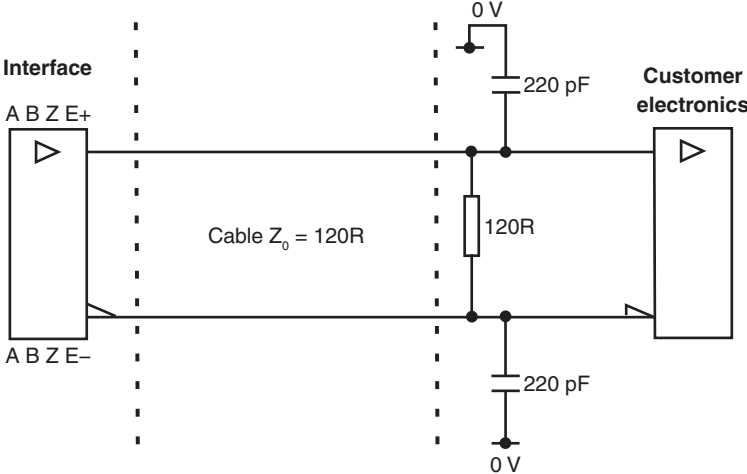

Standard RS422A line receiver circuitry.
The capacitors are recommended for improved noise immunity.

Ti digital single-ended alarm signal termination ²

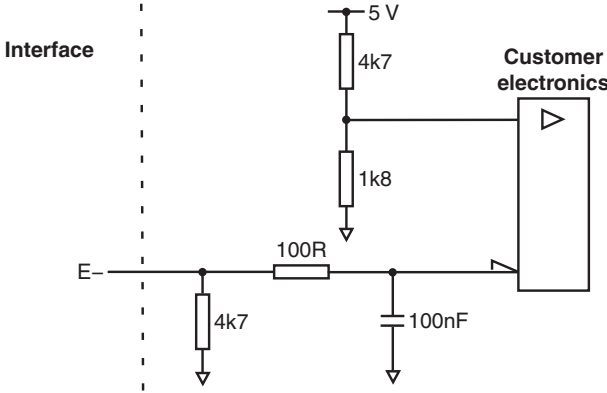

¹ Ti digital interface with 'options' E, F, G, or H selected (differential alarm options). See 'Ti interface part numbers' in the *TONiC™ encoder system* data sheet (Renishaw part no. L-9517-9337).

² Ti digital interface with 'options' A, B, C, or D selected (single-ended alarm options). See 'Ti interface part numbers' in the *TONiC™ encoder system* data sheet (Renishaw part no. L-9517-9337).

Analogue outputs

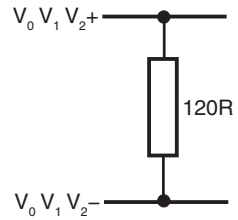

Limit outputs ¹

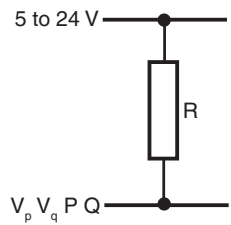

NOTE: Select the resistor R so that the maximum current does not exceed 20 mA.
 Alternatively use a suitable relay or opto-isolator.

Remote CAL operation (Analogue versions only)

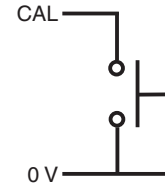

All Ti, TD and DOP interfaces include a push button switch to enable CAL/AGC features. However, remote operation of the CAL/AGC is possible via pin 14 of analogue Ti0000 interfaces. For applications where no interface is used, remote operation of CAL/AGC is essential.

TD interface resolution switching

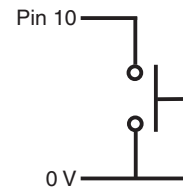

Connect pin 10 to 0 V to switch to lower resolution.

¹ No limits on TD interfaces.

Output specifications

Digital output signals

Ti digital, TD and DOP interfaces only

Form – Square wave differential line driver to EIA RS422A (except limits P and Q)

Incremental ¹

Two channels A and B in quadrature (90° phase shifted)

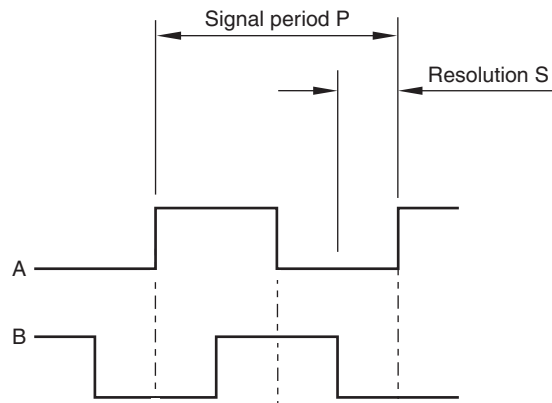

Interface model	P (µm)	S (µm)
Ti0004 and DOP0004	20	5
Ti0020, TD0040, and DOP0020	4	1
Ti0040, TD0040, and DOP0040	2	0.5
Ti0100, TD0200, and DOP0100	0.8	0.2
Ti0200, TD0200, TD0400, and DOP0200	0.4	0.1
Ti0400, TD0400, and DOP0400	0.2	0.05
TD1000	0.16	0.04
Ti1000, TD1000, TD2000, and DOP1000	0.08	0.02
Ti2000, TD2000, TD4000, and DOP2000	0.04	0.01
Ti4000, TD4000, and DOP4000	0.02	0.005
Ti10KD and DOP10KD	0.008	0.002
Ti20KD and DOP20KD	0.004	0.001

Reference ¹

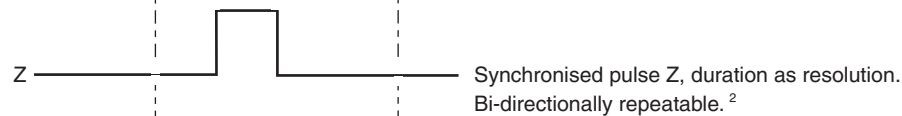

Wide reference ¹

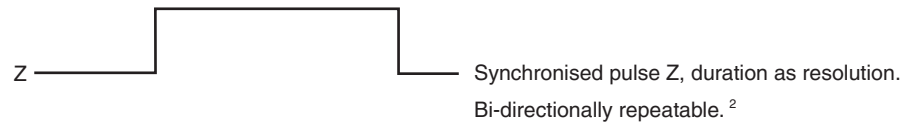

NOTES:

- Select 'standard' or 'wide' reference at time of ordering, to match the requirements of the controller being used. See 'Ti interface part numbers' in the *TONiC™ encoder system* data sheet (Renishaw part no. L-9517-9337).
- The wide reference mark option is not available with Ti0004.

¹ For clarity, the inverse signals are not shown.

² Only the calibrated reference mark is bi-directionally repeatable.

Limits

Open collector output, asynchronous pulse

Active high

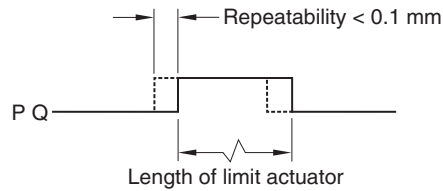

or active low

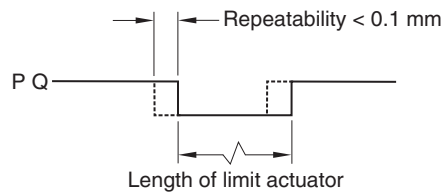

NOTES:

- There are no limits on TD interfaces.
- P limit becomes E+ for Ti interface options E, F, G and H.

Alarm ¹

Line driven (asynchronous pulse)

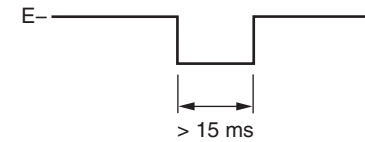

Alarm asserted when:

- The signal amplitude is < 20% or > 135%
- The readhead speed is too high for reliable operation

NOTE: Inverse signal E+ only available for DOP digital outputs, and Ti options E, F, G and H.

or 3-state alarm

Differentially transmitted signals forced open circuit for > 15 ms when alarm conditions valid.

Set-up

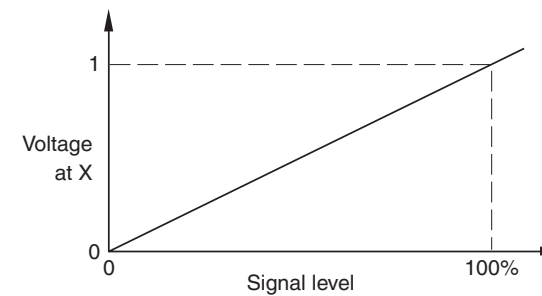

The set-up signal voltage is proportional to the incremental signal amplitude.²

¹ For clarity, the inverse signals are not shown.

² The set-up signal as shown is not present during the calibration routine.

Analogue output signals

Ti analogue (Ti0000), DOP (analogue output only), and direct output from all readheads

Incremental

Two channels V_1 and V_2 differential sinusoids in quadrature (90° phase shifted).

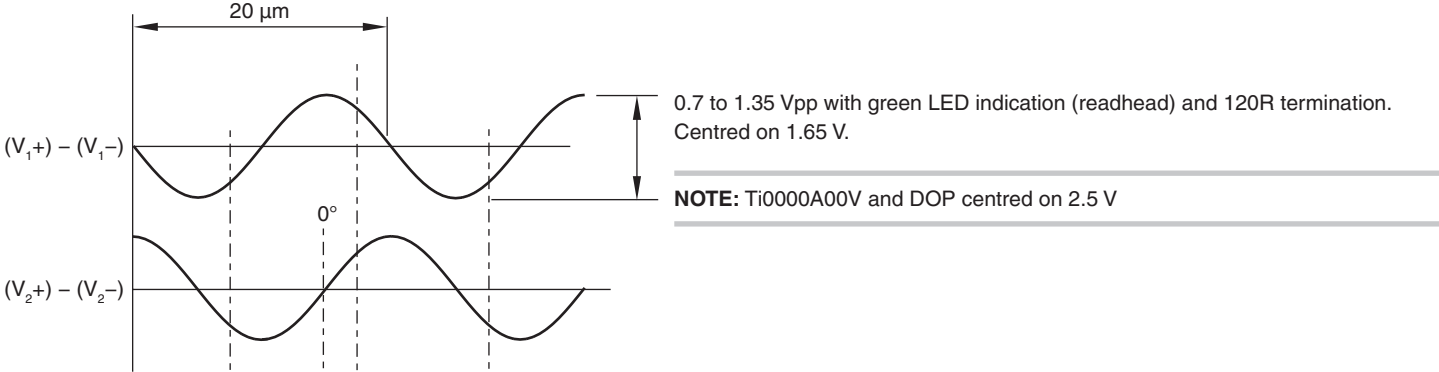

Reference

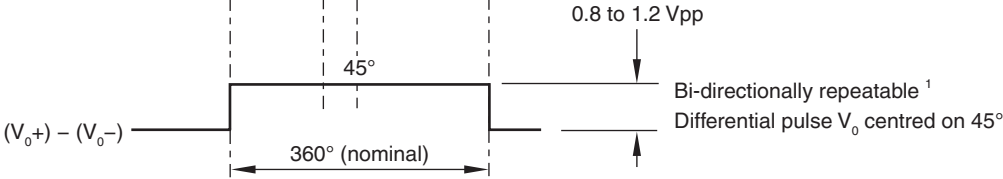

¹ Only the calibrated reference mark is bi-directionally repeatable.

Limits

Open collector output, asynchronous pulse

Ti0000 interfaces (active high)

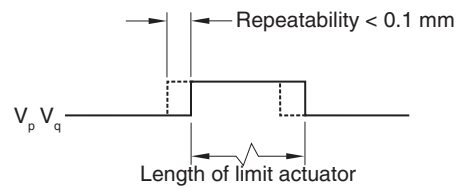

Direct output from readhead (active low)

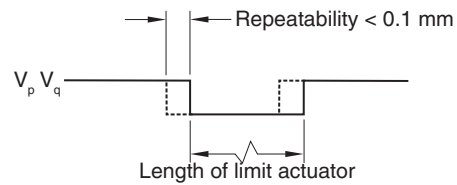

NOTES:

- The Ti0000 interface contains a transistor to invert the readhead's "active low" signal to give an "active high" output.
- For the DOP interface see 'Limits' in the digital outputs section on page 41.

Set-up ¹

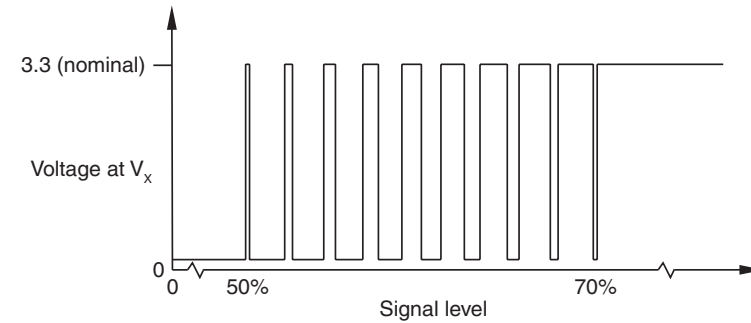

Between 50% and 70% the signal level V_x is a duty cycle.

Time spent at 3.3 V increases with incremental signal level.

At > 70% the signal level V_x is nominal 3.3 V.

NOTE: For the DOP interface see 'Set-up' in the digital outputs section on page 41.

¹ The set-up signal as shown is not present during the calibration routine.

General specifications

Power supply	5 V \pm 10%	TONiC readhead only < 100 mA TONiC readhead with Ti0000 < 100 mA TONiC readhead with Ti digital interface or TD interface < 200 mA TONiC readhead with DOP interface < 275 mA Current consumption figures refer to unterminated systems. For digital outputs a further 25 mA per channel pair (eg A+, A-) will be drawn when terminated with 120R. For analogue outputs a further 20 mA in total will be drawn when terminated with 120R. Power from a 5 V dc supply complying with the requirements for PELV of standard IEC 60950-1.
	Ripple	200 mVpp maximum @ frequency up to 500 kHz
Temperature	Storage (system)	-20 °C to +70 °C
	Operating (system)	0 °C to +70 °C
	Bakeout (UHV readhead)	+120 °C
Humidity	System	95% relative humidity (non-condensing) to IEC 60068-2-78
Sealing	Standard readhead	IP40
	UHV readhead	IP20
	Ti/TD interface	IP20
	DOP interface	IP30
Acceleration	Operating (readhead)	500 m/s ² , 3 axes
Shock	Operating (system)	500 m/s ² , 11 ms, ½ sine, 3 axes
Vibration	Operating (system)	Sinusoidal 100 m/s ² , 55 Hz to 2000 Hz, 3 axes
Mass	Readhead	10 g
	Ti/TD interface	100 g
	DOP interface	205 g
	Standard cable	26 g/m
	UHV cable	14 g/m
Readhead cable	Standard readhead	Double-shielded, outside diameter 4.25 \pm 0.25 mm Flex life > 20 \times 10 ⁶ cycles at 20 mm bend radius UL recognised component 
	UHV readhead	Tin coated braided single screen FEP core insulation
Maximum cable length	Readhead to interface	10 m
	Interface to controller	25 m (with 40 MHz to 50 MHz clocked output interface)
		50 m (with < 40 MHz clocked output interface)
		50 m (with analogue interface)

CAUTION: Renishaw encoder systems have been designed to the relevant EMC standards, but must be correctly integrated to achieve EMC compliance. In particular, attention to shielding arrangements is essential.

RTL20 scale specifications

Form (height × width)	0.2 mm × 8 mm
Pitch	20 μm
Accuracy (at 20 °C) - includes slope and linearity	±5 μm/m (calibration traceable to International Standards)
Linearity	±2.5 μm/m (achievable with two point error correction)
Supplied lengths ¹	20 mm up to 10 m (> 10 m on request)
Material	Hardened and tempered martensitic stainless steel
Mass	12.2 g/m
Coefficient of thermal expansion (at 20 °C)	10.1 ±0.2 μm/m/°C
Installation temperature	+10 °C to + 35 °C
Datum fixing	Loctite® 435™ or mechanical clamp (A-9589-0077)

FASTRACK carrier specifications

Form (height × width)	0.4 mm × 18 mm (includes adhesive)
Minimum recommended length	100 mm
Supplied lengths	100 mm to 25 m
Material	Hardened and tempered martensitic stainless steel
Mass	24 g/m
Coefficient of thermal expansion (at 20 °C)	10.1 ±0.2 μm/m/°C
Installation temperature	+10 °C to + 35 °C
Mounting	Self-adhesive backing tape

Reference mark



Type	Customer selected <i>IN-TRAC</i> reference mark, directly embedded into incremental track. Bi-directional position repeatability.
Selection	Single reference mark selection by selector magnet (A-9653-0143) customer positioned
L ≤ 100 mm	Single reference mark at scale centre
L > 100 mm	Reference marks at 50 mm spacing (first reference mark 50 mm from scale end)
Mounting	Self-adhesive backing tape
Repeatability	Unit of resolution repeatability (bi-directional) across full system rated speed and temperature ranges

Limit switches

Type	Magnetic actuators; with dimple triggers Q limit, without dimple triggers P limit (see ' RTL20/FASTRACK system installation drawing ' on page 14)
Trigger point	The limit output is nominally asserted when the readhead limit switch sensor passes the limit magnet leading edge, but can trigger up to 3 mm before that edge
Mounting	Self-adhesive backing tape. Customer placed at desired locations
Repeatability	< 0.1 mm

www.renishaw.com/contact

 #renishaw

 +44 (0) 1453 524524  uk@renishaw.com

© 2009–2026 Renishaw plc. All rights reserved. This document may not be copied or reproduced in whole or in part, or transferred to any other media or language by any means, without the prior written permission of Renishaw.
RENISHAW® and the probe symbol are registered trade marks of Renishaw plc. Renishaw product names, designations and the mark 'apply innovation' are trade marks of Renishaw plc or its subsidiaries. Other brand, product or company names are trade marks of their respective owners. Renishaw plc. Registered in England and Wales. Company no: 1106260. Registered office: New Mills, Wotton-under-Edge, Glos, GL12 8JR, UK.

WHILE CONSIDERABLE EFFORT WAS MADE TO VERIFY THE ACCURACY OF THIS DOCUMENT AT PUBLICATION, ALL WARRANTIES, CONDITIONS, REPRESENTATIONS AND LIABILITY, HOWSOEVER ARISING, ARE EXCLUDED TO THE EXTENT PERMITTED BY LAW. RENISHAW RESERVES THE RIGHT TO MAKE CHANGES TO THIS DOCUMENT AND TO THE EQUIPMENT, AND/OR SOFTWARE AND THE SPECIFICATION DESCRIBED HEREIN WITHOUT OBLIGATION TO PROVIDE NOTICE OF SUCH CHANGES.

Part no.: M-9589-9002-05-A
Issued: 04.2026