

RLE fibre optic laser encoder



This page is intentionally left blank.

Contents

1.	Legal notices	6
2.	System overview	10
2.1	System components.....	10
2.1.1	RLU laser unit	10
2.1.2	RLD detector heads.....	11
2.2	RLU output formats	13
2.3	RLU speed/resolution.....	14
2.4	Part numbers	16
2.5	Storage and handling.....	22
3.	Installation and set-up	23
3.1	Installation diagrams	23
3.1.1	RLU laser unit – horizontal mounting.....	23
3.1.2	RLU laser unit – vertical mounting.....	24
3.1.3	RLD 90° detector head	25
3.1.4	RLD 0° detector head	26
3.1.5	RLD retroreflector alignment dimensions.....	27
3.1.6	RLD DI detector head	28
3.2	Preparation.....	30
3.2.1	Cables	30
3.2.2	Reference mark switch.....	33
3.2.3	Error output signal	34
3.2.4	Reset input.....	35
3.2.5	Laser beam shutter	35
3.2.6	RLD connections	36

3.2.7	Operating the RLD shutter38
3.3	RLU configuration switches39
3.4	Front panel switch information40
3.5	RLU laser unit mounting considerations44
3.5.1	Front panel.45
3.5.2	RLU indicator LED information46
3.6	Alignment general47
3.6.1	Adjustment methods47
3.6.2	Signal strength.49
3.6.3	Alignment aids50
3.6.4	Retroreflector alignment process51
3.6.5	Plane mirror alignment process53
3.6.6	Differential interferometer alignment process54
4.	Connector pinouts57
Appendix A	- Interferometry63
A.1	Interferometry guide63
A.2	Retroreflector interferometry65
A.3	Plane mirror interferometry66
A.4	Differential interferometry.67
Appendix B	- Maintenance68
B.1	Adjustments and procedures68
B.2	General maintenance.69
B.3	Troubleshooting70
B.4	Matching RLD to RLU71
Appendix C	- Measurement errors73
C.1	Overview73

C.2 Cosine error74
Appendix D - Specifications75
D.1 System specifications75
Appendix E - Safety information79
E.1 Laser beam description and safety labels79
E.2 Motion system safety81
Appendix F - Glossary83

1. Legal notices

Safety

Before using the laser system, please consult the laser safety information booklet, which is available at www.renishaw.com/laserencoders.

Patents

Features of Renishaw's Laser encoder systems and similar products are the subjects of the following patents and patent applications:

EP(DE)1193402	EP(UK)1193402	EP(IT)1193402	US6776551	US7304815
CN100464471	EP(DE)1547211	EP(UK)1547211	EP(IT)1547211	JP4461018
CN1957225	EP(DE)1751491	EP(UK)1751491	US7525665	

Terms and conditions and warranty

Unless you and Renishaw have agreed and signed a separate written agreement, the equipment and/or software are sold subject to the Renishaw Standard Terms and Conditions supplied with such equipment and/or software, or available on request from your local Renishaw office.

Renishaw warrants its equipment and software for a limited period (as set out in the Standard Terms and Conditions), provided that they are installed and used exactly as defined in associated Renishaw documentation. You should consult these Standard Terms and Conditions to find out the full details of your warranty.

Equipment and/or software purchased by you from a third-party supplier is subject to separate terms and conditions supplied with such equipment and/or software. You should contact your third-party supplier for details.

Declaration of Conformity

Renishaw plc hereby declares that the RPI30 parallel interface is in compliance with the essential requirements and other relevant provisions of:

- the applicable EU directives
- the relevant statutory instruments under UK law

The full text of the declaration of conformity is available at www.renishaw.com/productcompliance.



Compliance

Federal Code Of Regulation (CFR) FCC Part 15 – RADIO FREQUENCY DEVICES

47 CFR Section 15.19

This device complies with part 15 of the FCC Rules. Operation is subject to the following two conditions: (1) This device may not cause harmful interference, and (2) this device must accept any interference received, including interference that may cause undesired operation.

47 CFR Section 15.21

The user is cautioned that any changes or modifications not expressly approved by Renishaw plc or authorised representative could void the user's authority to operate the equipment.

47 CFR Section 15.105

This equipment has been tested and found to comply with the limits for a Class A digital device, pursuant to part 15 of the FCC Rules. These limits are designed to provide reasonable protection against harmful interference when the equipment is operated in a commercial environment.

This equipment generates, uses, and can radiate radio frequency energy and, if not installed and used in accordance with the instruction manual, may cause harmful interference to radio communications. Operation of this equipment in a residential area is likely to cause harmful interference in which case the user will be required to correct the interference at his own expense.

47 CFR Section 15.27

This unit was tested with shielded cables on the peripheral devices. Shielded cables must be used with the unit to ensure compliance.

Supplier's Declaration of Conformity

47 CFR § 2.1077 Compliance Information

Unique Identifier: RLE fibre optic laser encoder

Responsible Party - U.S. Contact Information

Renishaw Inc.
 1001 Wesemann Drive
 West Dundee
 Illinois
 IL 60118
 United States
 Telephone number: +1 847 286 9953
 Email: usa@renishaw.com

ICES-003 – Information Technology Equipment (including Digital Apparatus)

This ISM device complies with Canadian ICES-003(A).

Cet appareil ISM est conforme à la norme ICES-003(A).

Intended use

The RLE system is a unique, advanced homodyne laser interferometer system specifically designed for position feedback applications. It must be installed, operated, and maintained as specified in Renishaw documentation and in accordance with the Standard Terms and Conditions of the Warranty and all other relevant legal requirements.

Packaging

The packaging of our products contains the following materials and can be recycled.

Packing component	Material	Material components	Material numerical code
Outer box	Cardboard - 70% recycled material	PAP	2
Inserts	Cardboard - 70% recycled material	PAP	20
Bag	Low density polyethylene	LDPE	4

REACH regulation

Information required by Article 33(1) of Regulation (EC) No. 1907/2006 ("REACH") relating to products containing substances of very high concern (SVHCs) is available at www.renishaw.com/REACH.

Disposal of waste electrical and electronic equipment



The use of this symbol on Renishaw products and/or accompanying documentation indicates that the product should not be mixed with general household waste upon disposal. It is the responsibility of the end user to dispose of this product at a designated collection point for waste electrical and electronic equipment (WEEE) to enable reuse or recycling. Correct disposal of this product will help to save valuable resources and prevent potential negative effects on the environment. For more information, contact your local waste disposal service or Renishaw distributor.

Care of equipment

Renishaw RLE fibre optic laser encoders and associated products are precision components and must therefore be treated with care. For further information refer to '[Appendix B - Maintenance](#)'.

Safety

It is the responsibility of the manufacturer and/or encoder installation authority to ensure that, in safety critical applications of the RLE fibre optic laser encoder, any form of signal deviation from specification or from the limits of the receiving electronics, howsoever caused, shall not cause the machine to become unsafe. It is also their responsibility to ensure that the end user is made aware of any hazards involved in operation of their machine, including those mentioned in Renishaw product documentation, and to ensure that adequate guards and safety interlocks are provided.

When mounting and using Renishaw laser encoder products on machines, beware of pinch and/or crush hazards that can be created depending on how and where the equipment is mounted. This warning is particularly relevant to the mounting of the optics of the RLE fibre optic laser encoder.

The Renishaw RLE fibre optic laser encoder contains precision glass components and fibre optics. In the unlikely event that the flexible steel conduit is cut or severed, splinters of fibre optic may be produced.

Should the fibre optic become damaged, the RLU laser unit must be carefully removed and returned to the nearest Renishaw office. Eye protection and protective gloves must be worn when handling damaged or exposed fibre optics. The unit should be packaged in a suitable thick-walled cardboard box, clearly marked "Caution: exposed fibre optics, handle with care" on the outside of the box.

No attempt should be made to repair or dismantle the fibres from the laser unit.

Fibre optic splinters can be very small and extremely sharp. Should any fibre optic splinter become embedded in the skin, medical attention should be sought immediately.

NOTE: Fibre optic splinters do not show up on X-rays.

Laser safety



DO NOT STARE DIRECTLY INTO THE BEAM

In accordance with EN60825-1, EN60825-2 and US standards 21CFR 1040 and ANSI Z136.1, Renishaw RLE lasers are Class II lasers and safety goggles are not required, since the blink reaction of a human will protect the eye from damage. Do not stare into the beam or shine it into the eyes of others. It is safe to view a diffuse-reflected beam. Do not dismantle the unit in any way; doing so may expose laser radiation in excess of Class II limits. For further product and motion system safety information refer to '[Appendix E - Safety information](#)'.

Electrical safety



Do not remove any part of the housing; to do so may expose a danger of high voltage electric shock. Defective products should be returned to Renishaw for service.

2. System overview

The RLE fibre optic laser encoder is available as either a single or dual axis system, a single axis system having a single fibre optic output, and a dual axis two outputs.

2.1 System components

2.1.1 RLU laser unit

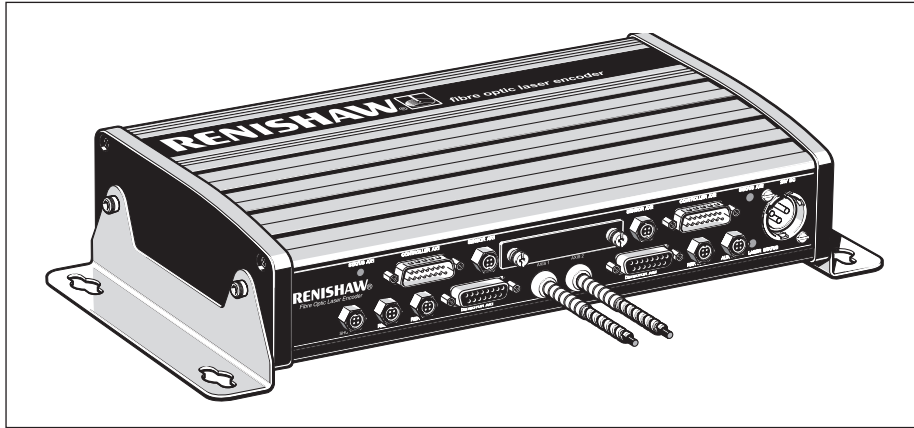

Figure 1 RLU laser unit

The RLE fibre optic laser encoder is available with two laser unit variants:

- RLU10
- RLU20

The RLU20 offers superior laser frequency stability. Both are available as single or dual axis variants, with optical fibre lengths of 3 m for RLU10/RLU20 and 6 m for RLU10 (for connection to RLD detector heads).

The laser unit contains the frequency stabilised laser tube, fibre optic launch optics and signal processing circuitry.

Electrical fringe signals returned from the detector head are processed in the RLU laser unit to convert them into standard digital A quad B or analogue sine and cosine position feedback signals, which can be used directly by the axis controller. Alternatively, if compensation is required, the RLU feedback signal is sent to the controller via an intermediate compensator (RCU). The RCU is designed to compensate for environmental effects on the laser wavelength and material thermal expansion.

The RLU laser front panel includes status indicators to aid installation and provide the operator with information to optimise the system performance.

The RLU laser unit can be mounted remotely from the detector heads, removing a significant heat source and extra mass from the measurement zone, as well as providing maximum flexibility in installation.

2.1.2 RLD detector heads

The RLE fibre optic laser encoder is available with six detector head variants:

- RLD 0° RRI (retroreflector)
- RLD 90° RRI (retroreflector)
- RLD 0° PMI (plane mirror)
- RLD 90° PMI (plane mirror)
- RLD XX (no internal optics)
- RLD DI (differential interferometer)

The user can order a plane mirror (PMI) or retroreflector (RRI) configuration with either 0° or 90° launch, or a differential interferometer, depending upon the preferred optical configuration for that application.

The RLD detector heads form the optical core of the measuring system. They incorporate an interferometer, reference optics (where applicable) and beam steering optics which are used to minimise the installation time and alignment complexity.

The fringe detection scheme is also contained in the head, converting the interference fringes into an electronic signal to be passed back to the laser unit for further processing.

The RLDs include a fibre optic connection at the detector head and an electrical cable connection at the laser unit (the RLD DI electrical cable is a separate item connecting at both the detector head and laser unit). This permits the interchangeability of RLDs ¹ and the ability to pass both the fibre and the cable through minimum sized cable tracks and trunking. The detector head incorporates a safety interlock that prevents a laser beam being emitted if either the fibre or the electrical cable is disconnected.

The RLD 0° detector head can be mounted on either the top or the bottom face.

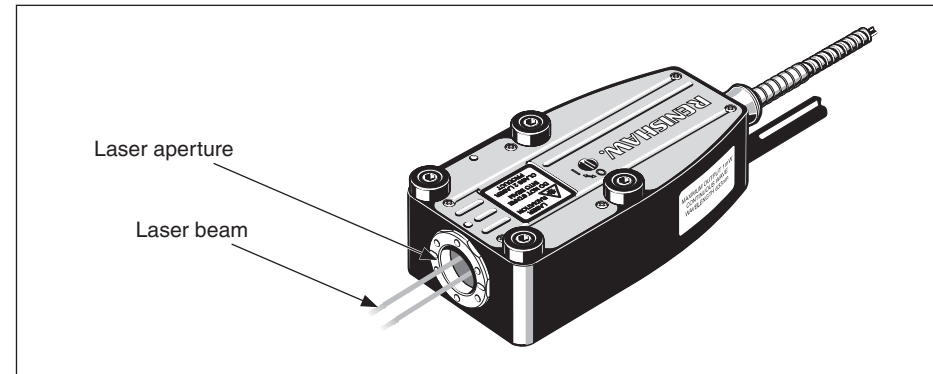

Figure 2 RLD 0° and RLD XX detector head

The RLD 90° detector head can be mounted on either the top or the bottom face, providing 90° or 270° laser output from the same head.

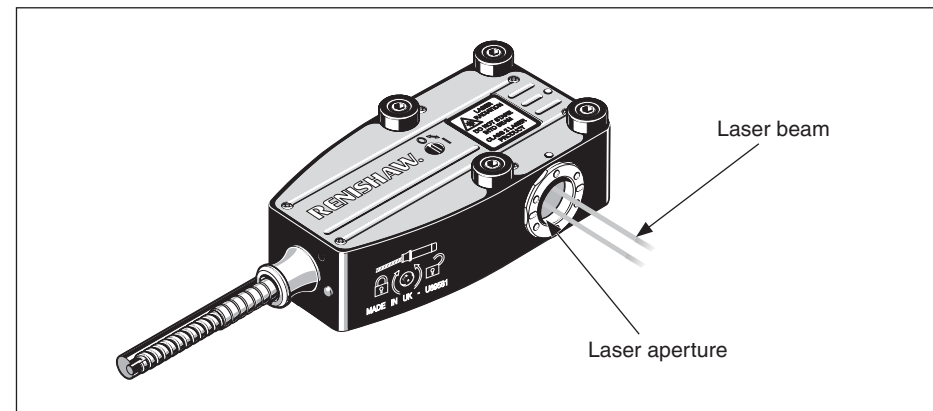

Figure 3 RLD 90° detector head

¹ Although RLDs are interchangeable, they have to be adjusted to match the RLU laser unit as described in Appendix B.4.

2.2 RLU output formats

The RLU can output fine and coarse digital quadrature simultaneously or, alternatively, fine digital quadrature and analogue sine/cosine simultaneously.

Digital quadrature:

Square wave digital quadrature signals in two-channel A quad B format, A and B signals having a 90° phase shift.

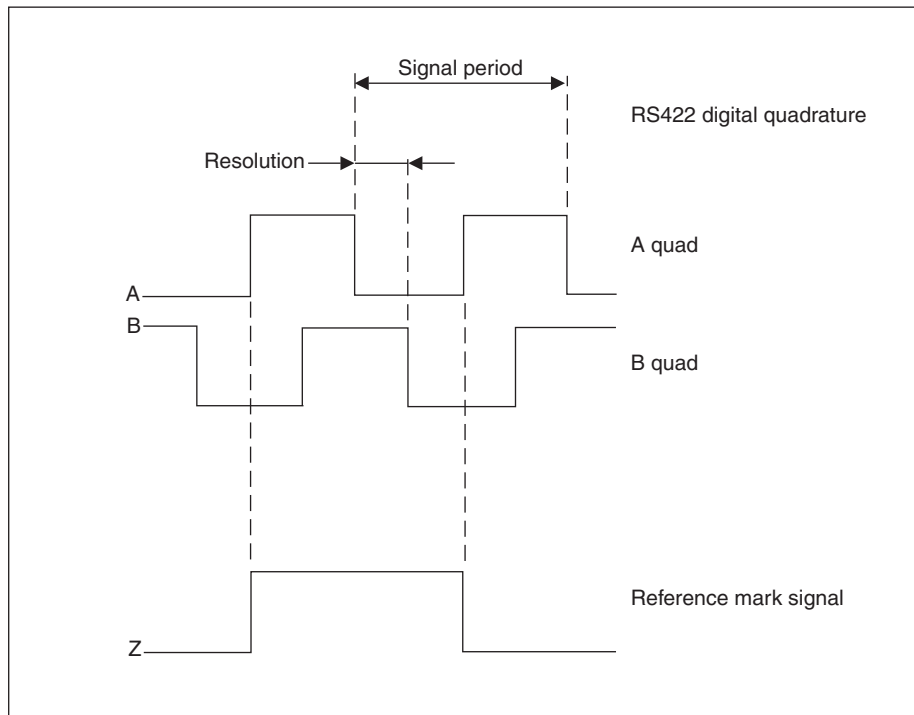

Figure 5 RS422 differential line driver outputs (only one side of differential signal is shown for clarity)

Analogue quadrature:

Sine and cosine signal output. Each signal is a nominal 1 Vpp sinusoid when the optics are correctly aligned, and the outputs are correctly terminated with 120 Ω. Amplitude is reduced as the optics are misaligned or as the optical path length reaches the maximum specification.

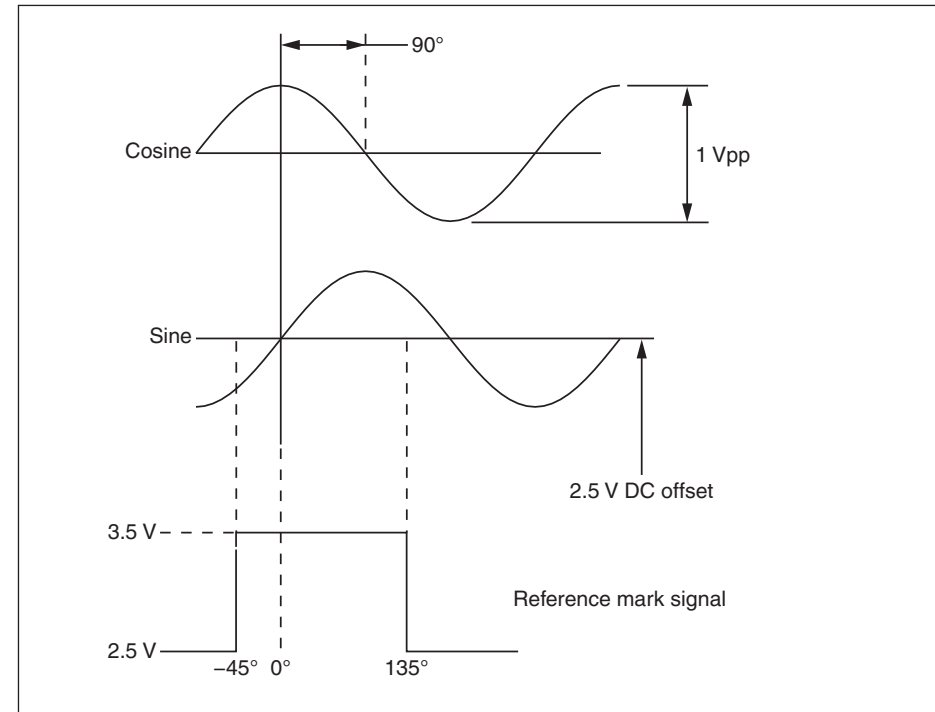

Figure 6 Analogue differential line driver outputs (only one side of differential signal is shown for clarity)

2.3 RLU speed/resolution

Exact resolution values

The available output resolutions are derived by division of the laser fundamental wavelength. These resolution values have been rounded up in the documentation for ease of use. The actual values are shown in Table 3 (vacuum values) and Table 4 (NTP values) on page 15.

The maximum axis velocities for the RLE system are related to the resolution which is selected (and vice versa). The resolutions available also depend on which interferometry method is being used (plane mirror or retroreflector). The maximum system velocities for given resolutions are shown in Table 1.

Analogue quadrature is only supplied with signal periods of 158 nm (PMI/DI configuration) and 316 nm (RRI configuration). If different resolutions are required, the signals must be processed outside the RLE system.



WARNING: It is important to set the output resolution of the RLE fibre optic laser encoder to match the controller's input resolution. If the quadrature resolution is set incorrectly, the axis may move for distances and at speeds that are not expected.

For example, if the output resolution from the RLE system is set to half that of the controller input, the axis may move twice as far and twice as fast as expected.

Table 1 Maximum system velocities

Nominal resolution (nm)	PMI/DI maximum speed (m/s)			RRI maximum speed (m/s)		
	Quadrature			Quadrature		
	Fine digital	Coarse digital	Analogue	Fine digital	Coarse digital	Analogue
633	-	-	-	-	2.0	-
316	-	1.0	-	-	2.0	2.0
158	-	1.0	1.0	0.8	2.0	-
79	0.4	1.0	-	0.8	1.6	-
39.5	0.4	0.8	-	0.8	-	-
20	0.4	-	-	0.4	-	-
10	0.2	-	-	-	-	-

NOTE: Resolution is the edge to edge separation of the digital quadrature signals (see section 2.2).



WARNING: The customer's controller must have an input bandwidth which is at least 25% greater than the output bandwidth of the RLU when using digital quadrature.

Table 2 Vacuum wavelength

AX1	AX2
632.990000 nm	632.991450 nm

Table 3 RLE output resolutions - vacuum

Nominal resolution (nm)	AX1 actual (nm)	AX2 actual (nm)
633 ¹	632.990000	632.991450
316	316.495000	316.495725
158	158.247500	158.247863
79	79.123750	79.123931
39.5	39.561875	39.561966
20	19.780938	19.780983
10 ²	9.890469	9.890491

When using an RLD DI head, the actual values for AX1 and AX2 shown above should be increased by 0.1 ppm. Resolutions are directly derived from the wavelength. The resolutions of the system at 20 °C, 1013.25 mbar, 50% RH (NTP values) are given in Table 4.

Table 4 RLE output resolutions – NTP

Nominal resolution (nm)	AX1 actual (nm)	AX2 actual (nm)
633 ¹	632.818270	632.819719
316	316.409135	316.409860
158	158.204567	158.204930
79	79.1022837	79.1024649
39.5	39.5511418	39.5512324
20	19.7755709	19.7756162
10 ²	9.88778546	9.88780811

When using an RLD DI head, the actual values for AX1 and AX2 shown above should be increased by 0.1 ppm. The following changes in the air from the NTP values will affect laser wavelength as follows:

Table 5 Effects of air changes on wavelength

Parameter	Change	Wavelength effect
Temperature	+1 °C	+0.96 ppm
Pressure	-1 mbar	+0.27 ppm
Humidity	+1% RH	+0.0085 ppm

ppm = parts per million (i.e. 1 µm per meter)

NOTE: These values only apply at values close to NTP. To calculate the effect over a wider range, it is recommended that you use the Edlen (or similar) equation.

¹ Not available with plane mirror configuration

² Not available with retroreflector configuration

2.4 Part numbers

The RLE fibre optic laser encoder comprises a number of different elements. The RLU laser unit and RLD detector head are core components which are available in different configurations, each with its own unique part number.

RLU laser unit

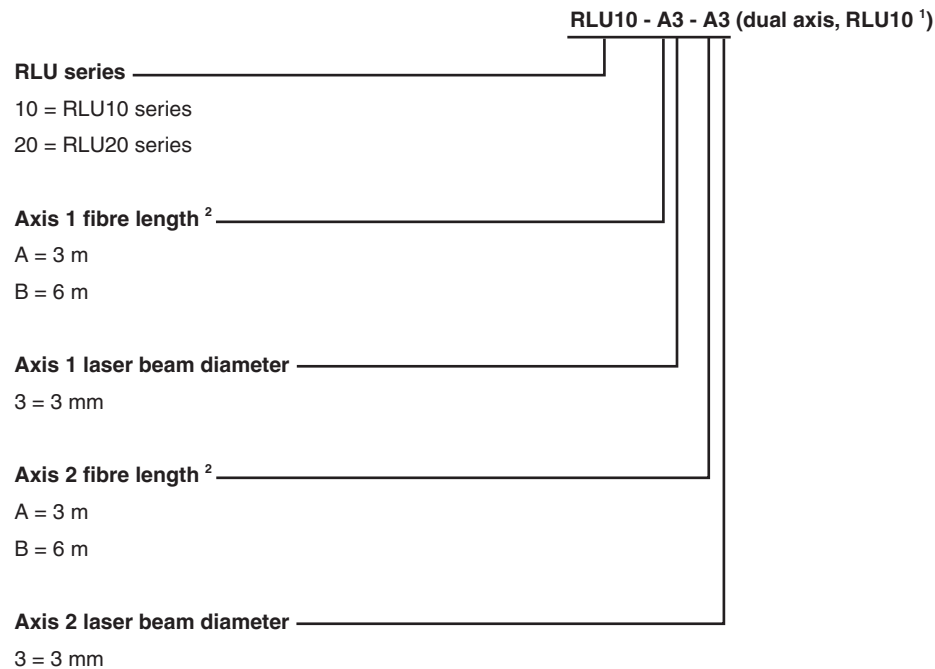

¹ For a single axis RLU, place xx in the last two digit spaces of the part number.

² It is not possible to have an RLU with different fibre lengths on each axis.

RLD detector head

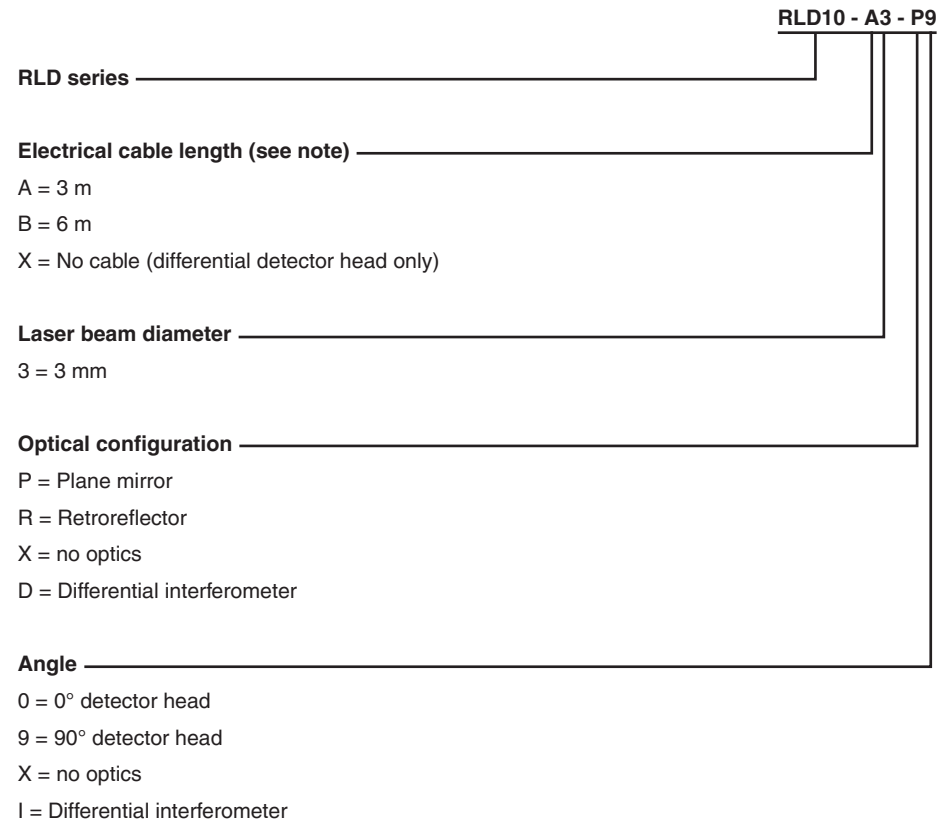

NOTE: When ordering an RLD10-X3-DI detector head, the electrical cable is supplied as a separate item (A-5225-0260 for a 3 m cable) unless purchased as part of an RLE system.

The RLD10 may be ordered without interferometer optical components fitted. This option will be required where external optics are to be used for straightness/angular measurements (e.g. RLD10-A3-XX).

Ordering a complete RLE system

Once the configuration and appropriate part numbers for the RLU and RLD(s) have been established, a system part number can be generated from Tables 6 (page 18) and 7 (page 19) for an RLE10 system and Tables 8 (page 20) and 9 (page 21) for an RLE20 system.

Example

RLE10-DX-XG contains the following:

- 1 off RLU10-A3-A3 (dual axis RLU10 laser unit)
- 1 off A-9904-1342 (fixing kit)
- 2 off RLD10-A3-P9 (plane mirror head 90° output)
- 2 off A-9904-1268 (fixing kit and alignment aid)
- 1 off installation guide
- 1 off safety booklet

The detector head(s) will have been prematched to the laser unit before shipment.

Calibration certificates

Calibration certificates are available as an added cost option and must be ordered at the same time as the laser. Certificates are not available retrospectively.

Complete system part numbers

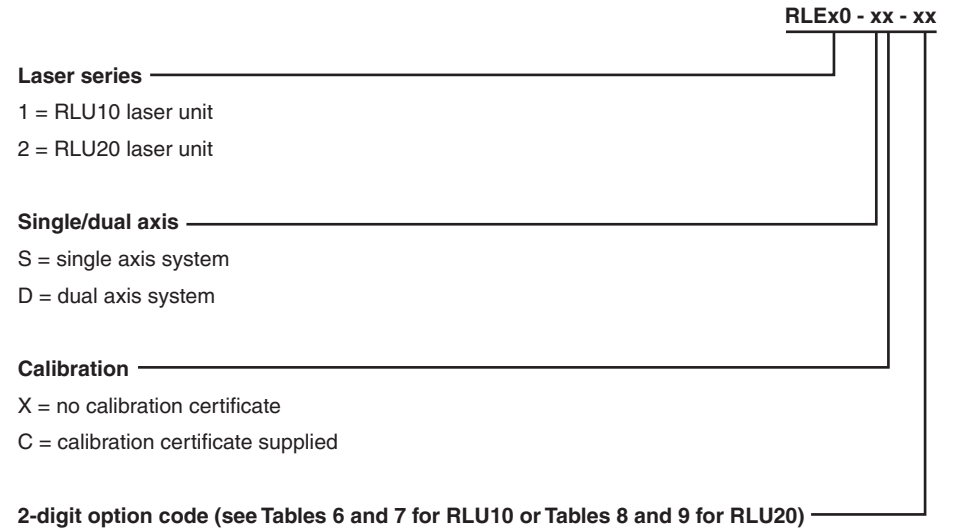

Table 6 Part numbers for RLE10 single axis systems

For 6 m RLE systems, replace the second last 'X' in the part number for a 'V'. For example, 'RLE10-DC-XF' would be 'RLE10-DC-VF' for a 6 m version.

	RLU LASER UNITS		RLD DETECTOR HEADS						RETROREFLECTOR	Calibration certificate
	RLU10-A3-XX	RLU10-A3-A3	RLD10-A3-P9	RLD10-A3-P0	RLD10-A3-R9	RLD10-A3-R0	RLD10-A3-XX	RLD10-X3-DI	RLR10-A3-XF	
RLE10-SC-XA	1	-	-	1	-	-	-	-	-	✓
RLE10-SX-XA	1	-	-	1	-	-	-	-	-	-
RLE10-SC-XB	1	-	1	-	-	-	-	-	-	✓
RLE10-SX-XB	1	-	1	-	-	-	-	-	-	-
RLE10-SC-XC	1	-	-	-	-	1	-	-	1	✓
RLE10-SX-XC	1	-	-	-	-	1	-	-	1	-
RLE10-SC-XD	1	-	-	-	1	-	-	-	1	✓
RLE10-SX-XD	1	-	-	-	1	-	-	-	1	-
RLE10-SC-XE	1	-	-	-	-	-	1	-	-	✓
RLE10-SX-XE	1	-	-	-	-	-	1	-	-	-
RLE10-SC-XR	1	-	-	-	-	-	-	1	-	✓
RLE10-SX-XR	1	-	-	-	-	-	-	1	-	-

NOTE: Configurations and part numbers are for typical systems only. Please check for configurations not shown.

Table 7 Part numbers for RLE10 dual axis systems

	RLU LASER UNITS		RLD DETECTOR HEADS						RETROREFLECTOR	Calibration certificate
	RLU10-A3-XX	RLU10-A3-A3	RLD10-A3-P9	RLD10-A3-P0	RLD10-A3-R9	RLD10-A3-R0	RLD10-A3-XX	RLD10-X3-DI	RLR10-A3-XF	
RLE10-DC-XF	-	1	-	2	-	-	-	-	-	✓
RLE10-DX-XF	-	1	-	2	-	-	-	-	-	-
RLE10-DC-XG	-	1	2	-	-	-	-	-	-	✓
RLE10-DX-XG	-	1	2	-	-	-	-	-	-	-
RLE10-DC-XH	-	1	①	1	-	-	-	-	-	✓
RLE10-DX-XH	-	1	①	1	-	-	-	-	-	-
RLE10-DC-XI	-	1	-	-	-	-	2	-	-	✓
RLE10-DX-XI	-	1	-	-	-	-	2	-	-	-
RLE10-DC-XJ	-	1	-	-	-	2	-	-	2	✓
RLE10-DX-XJ	-	1	-	-	-	2	-	-	2	-
RLE10-DC-XK	-	1	-	-	2	-	-	-	2	✓
RLE10-DX-XK	-	1	-	-	2	-	-	-	2	-
RLE10-DC-XL	-	1	-	-	①	1	-	-	2	✓
RLE10-DX-XL	-	1	-	-	①	1	-	-	2	-
RLE10-DC-XM	-	1	①	-	-	1	-	-	1	✓
RLE10-DX-XM	-	1	①	-	-	1	-	-	1	-
RLE10-DC-XN	-	1	-	①	1	-	-	-	1	✓
RLE10-DX-XN	-	1	-	①	1	-	-	-	1	-
RLE10-DC-XP	-	1	-	-	-	-	-	2	-	✓
RLE10-DX-XP	-	1	-	-	-	-	-	2	-	-

NOTES:

- Configurations and part numbers are for typical systems only. Please check for configurations not shown.
- A circle around the number of detectors denotes that the detector is configured for use with Axis 1.

Table 8 Part numbers for RLE20 single axis systems

	RLU LASER UNITS		RLD DETECTOR HEADS						RETROREFLECTOR	Calibration certificate
	RLU20-A3-XX	RLU20-A3-A3	RLD10-A3-P9	RLD10-A3-P0	RLD10-A3-R9	RLD10-A3-R0	RLD10-A3-XX	RLD10-X3-DI	RLR10-A3-XF	
RLE20-SC-XA	1	-	-	1	-	-	-	-	-	✓
RLE20-SX-XA	1	-	-	1	-	-	-	-	-	-
RLE20-SC-XB	1	-	1	-	-	-	-	-	-	✓
RLE20-SX-XB	1	-	1	-	-	-	-	-	-	-
RLE20-SC-XC	1	-	-	-	-	1	-	-	1	✓
RLE20-SX-XC	1	-	-	-	-	1	-	-	1	-
RLE20-SC-XD	1	-	-	-	1	-	-	-	1	✓
RLE20-SX-XD	1	-	-	-	1	-	-	-	1	-
RLE20-SC-XE	1	-	-	-	-	-	1	-	-	✓
RLE20-SX-XE	1	-	-	-	-	-	1	-	-	-
RLE20-SC-XR	1	-	-	-	-	-	-	1	-	✓
RLE20-SX-XR	1	-	-	-	-	-	-	1	-	-

NOTE: Configurations and part numbers are for typical systems only. Please check for configurations not shown.

Table 9 Part numbers for RLE20 dual axis systems

	RLU LASER UNITS		RLD DETECTOR HEADS						RETROREFLECTOR	Calibration certificate
	RLU20-A3-XX	RLU20-A3-A3	RLD10-A3-P9	RLD10-A3-P0	RLD10-A3-R9	RLD10-A3-R0	RLD10-A3-XX	RLD10-X3-DI	RLR10-A3-XF	
RLE20-DC-XF	-	1	-	2	-	-	-	-	-	✓
RLE20-DX-XF	-	1	-	2	-	-	-	-	-	-
RLE20-DC-XG	-	1	2	-	-	-	-	-	-	✓
RLE20-DX-XG	-	1	2	-	-	-	-	-	-	-
RLE20-DC-XH	-	1	①	1	-	-	-	-	-	✓
RLE20-DX-XH	-	1	①	1	-	-	-	-	-	-
RLE20-DC-XI	-	1	-	-	-	-	2	-	-	✓
RLE20-DX-XI	-	1	-	-	-	-	2	-	-	-
RLE20-DC-XJ	-	1	-	-	-	2	-	-	2	✓
RLE20-DX-XJ	-	1	-	-	-	2	-	-	2	-
RLE20-DC-XK	-	1	-	-	2	-	-	-	2	✓
RLE20-DX-XK	-	1	-	-	2	-	-	-	2	-
RLE20-DC-XL	-	1	-	-	①	1	-	-	2	✓
RLE20-DX-XL	-	1	-	-	①	1	-	-	2	-
RLE20-DC-XM	-	1	①	-	-	1	-	-	1	✓
RLE20-DX-XM	-	1	①	-	-	1	-	-	1	-
RLE20-DC-XN	-	1	-	①	1	-	-	-	1	✓
RLE20-DX-XN	-	1	-	①	1	-	-	-	1	-
RLE20-DC-XP	-	1	-	-	-	-	-	2	-	✓
RLE20-DX-XP	-	1	-	-	-	-	-	2	-	-

NOTES:

- Configurations and part numbers are for typical systems only. Please check for configurations not shown.
- A circle around the number of detectors denotes that the detector is configured for use with Axis 1.

2.5 Storage and handling

The RLE fibre optic laser encoder can be stored at temperatures between $-20\text{ }^{\circ}\text{C}$ and $+70\text{ }^{\circ}\text{C}$ ($-4\text{ }^{\circ}\text{F}$ and $+158\text{ }^{\circ}\text{F}$).

Do not store the RLE fibre optic laser encoder in conditions of high humidity or otherwise subject it to conditions which may cause condensation to form on the RLD optics.

Renishaw's fibre optic laser encoders and associated equipment are precision optical and electronic tools used for obtaining precise measurements and must therefore be treated with appropriate care.

Ensure protection is provided for both the RLE and the associated optics when transporting a machine with the equipment already installed.

Refer to '[Appendix B - Maintenance](#)' for maintenance and cleaning instructions.

3. Installation and set-up

3.1 Installation diagrams

3.1.1 RLU laser unit – horizontal mounting

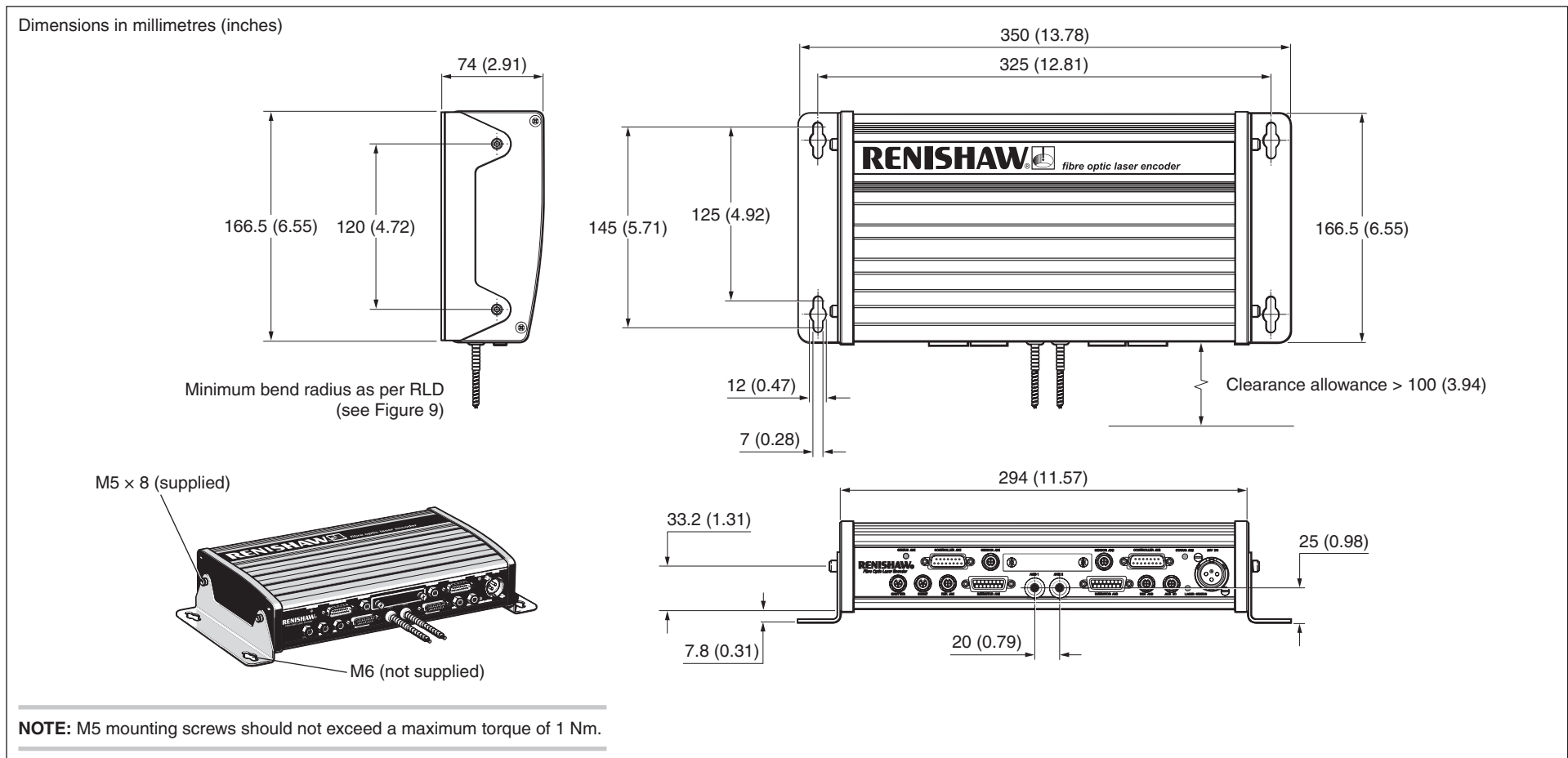

Figure 7 Dimensions of RLU laser unit (horizontal mounting)

3.1.2 RLU laser unit – vertical mounting

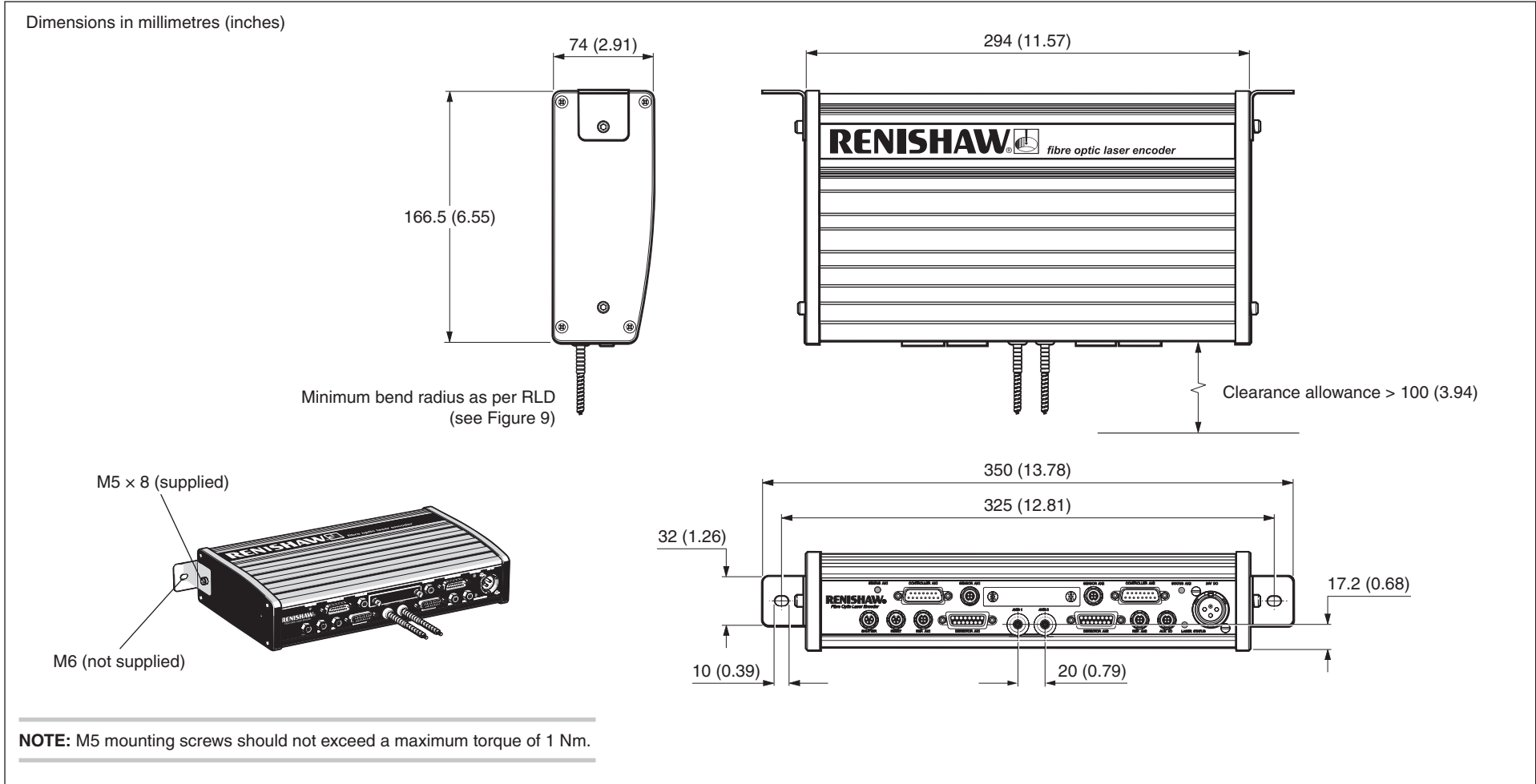

Figure 8 Dimensions of RLU laser unit (vertical mounting)

3.1.3 RLD 90° detector head

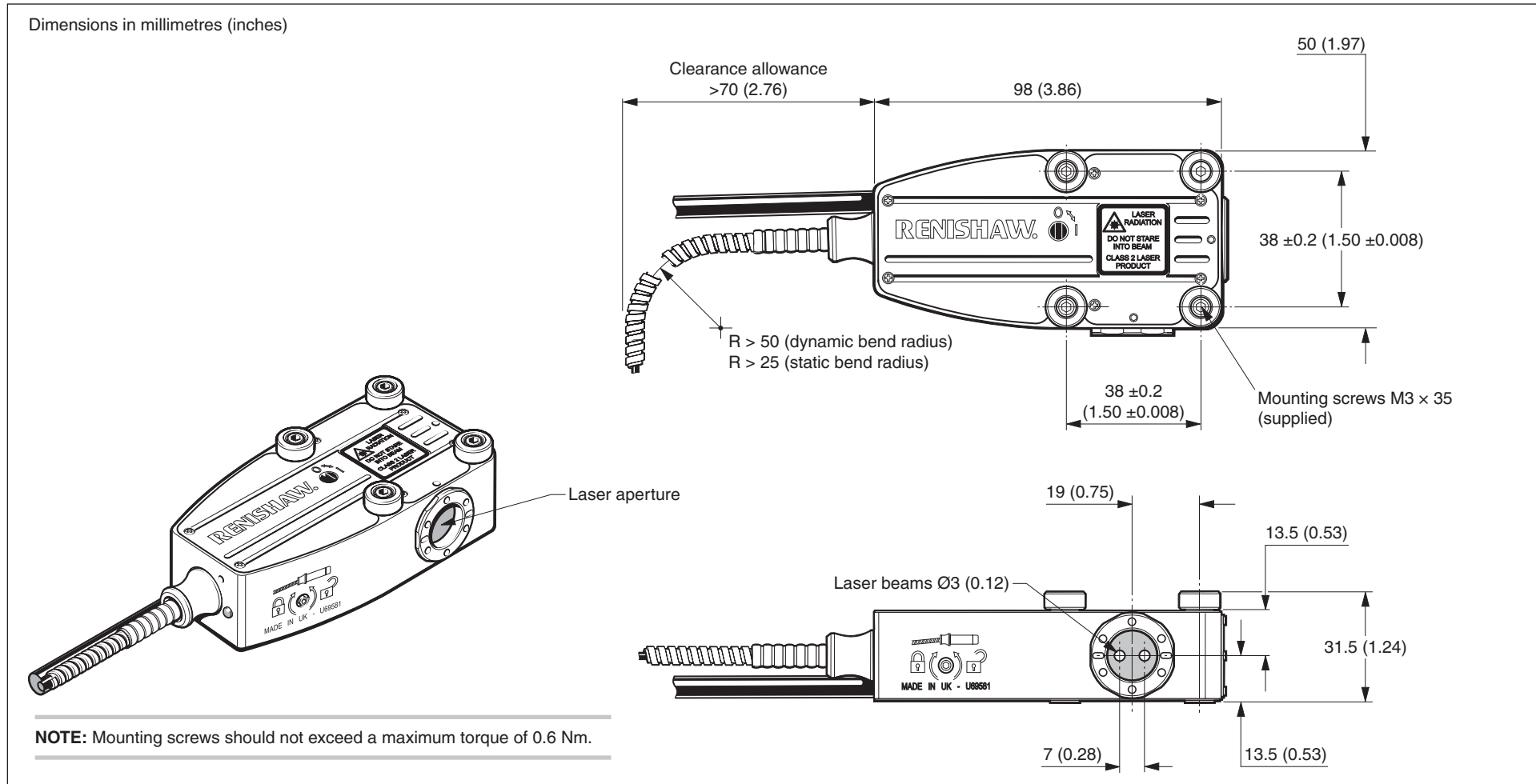

Figure 9 Dimensions of RLD 90° detector head

3.1.4 RLD 0° detector head

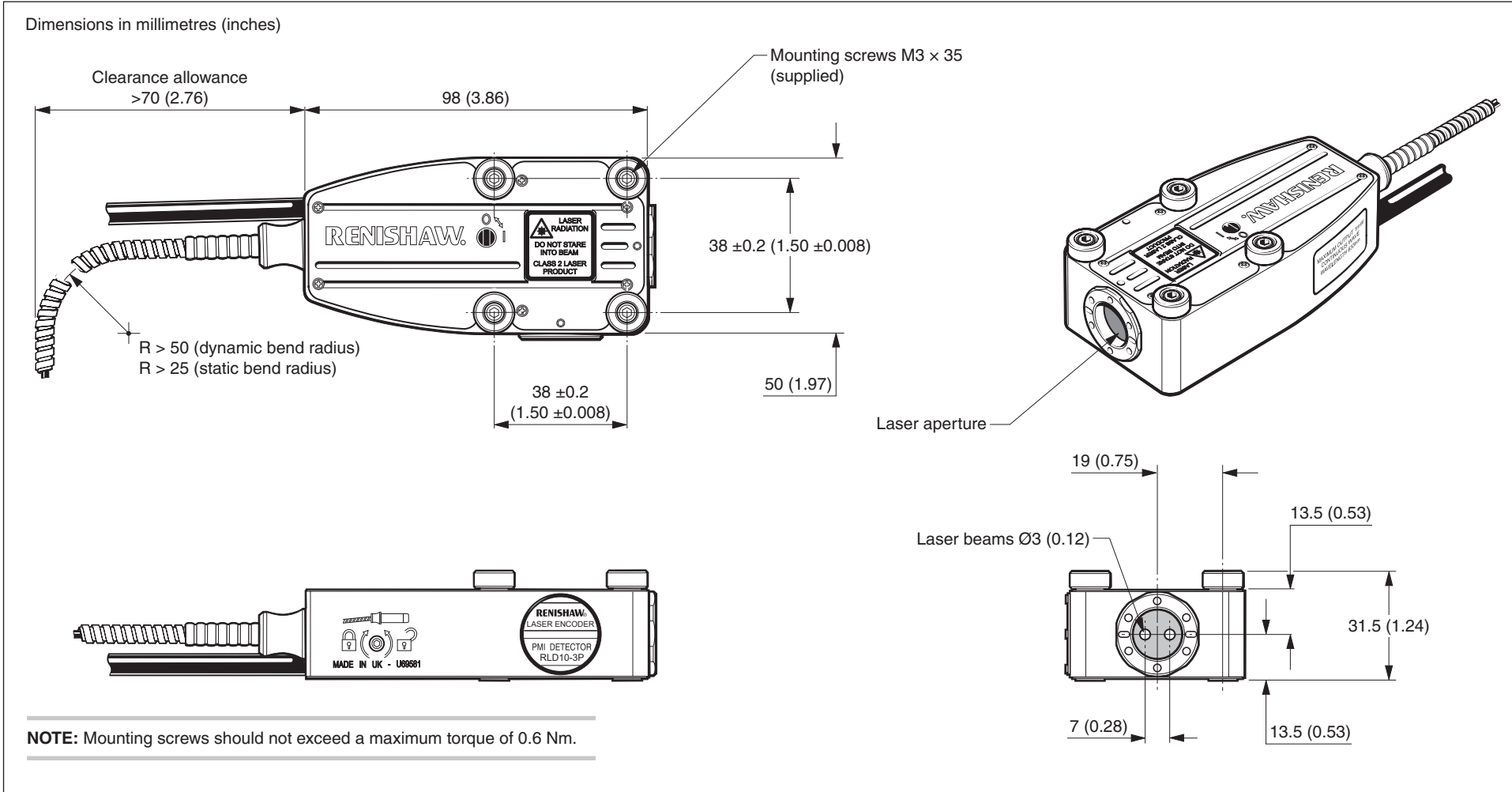

Figure 10 Dimensions of RLD 0° detector head

3.1.5 RLD retroreflector alignment dimensions

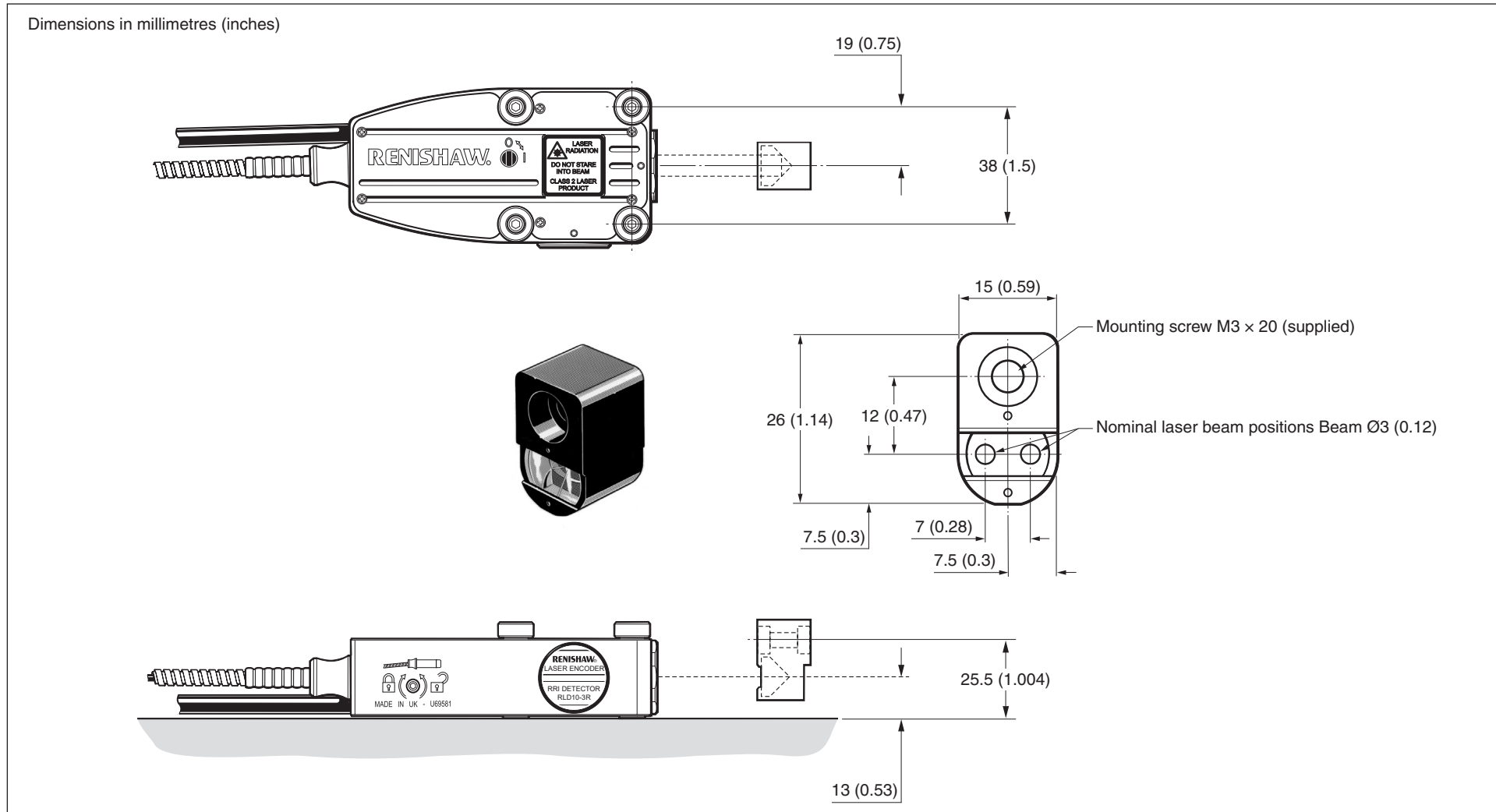

Figure 11 RLD retroreflector alignment dimensions

3.1.6 RLD DI detector head

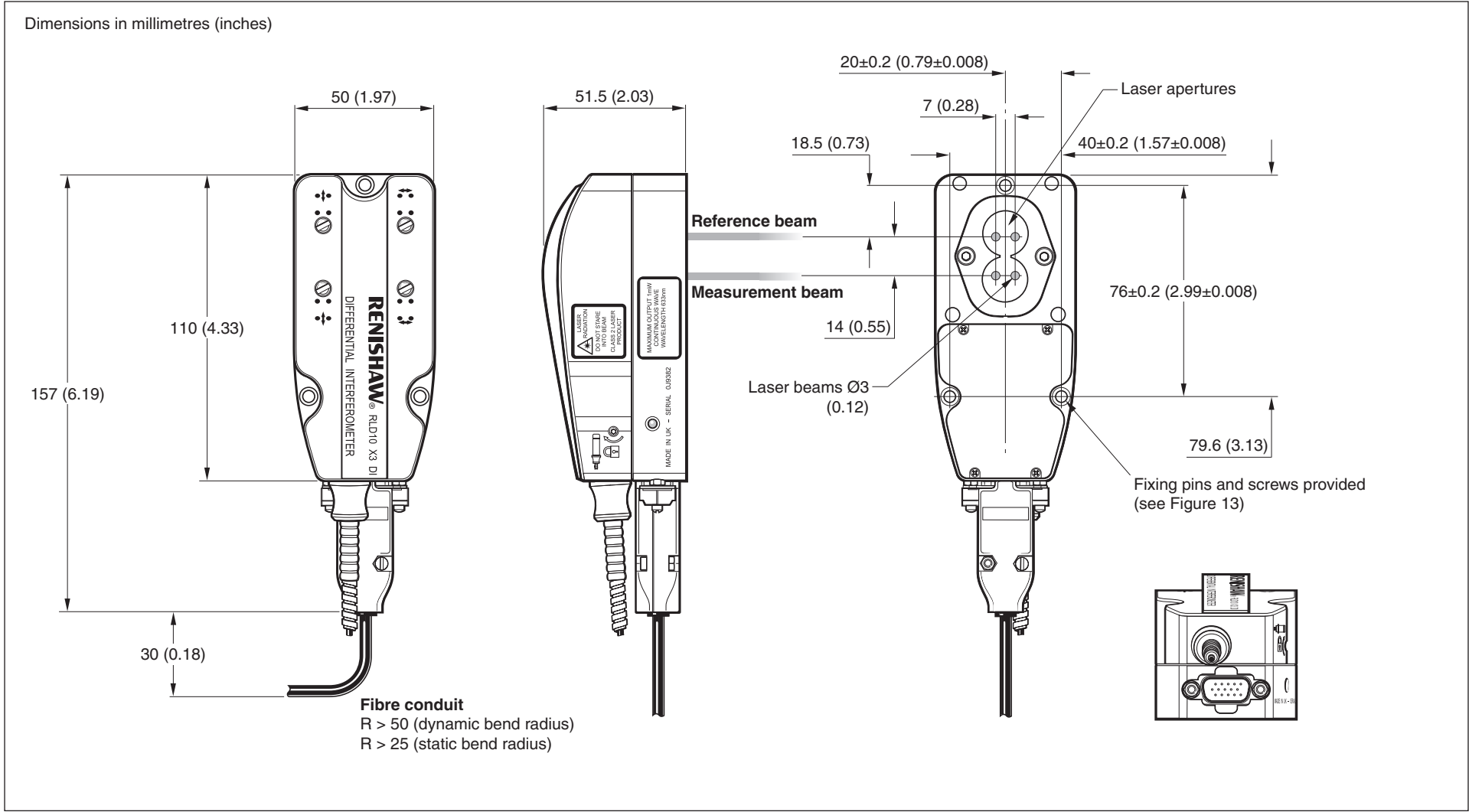

Figure 12 Dimensions of RLD DI detector head

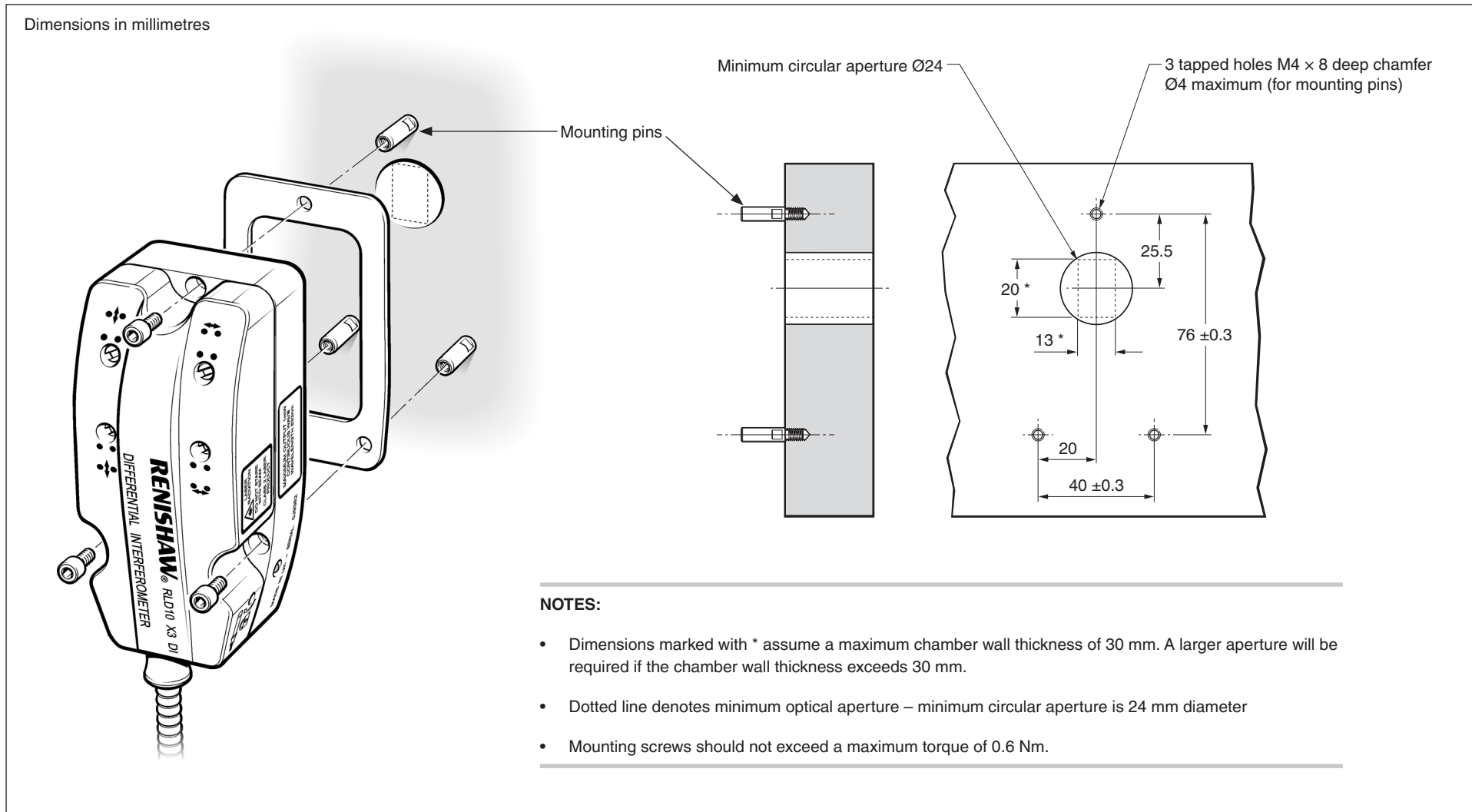

Figure 13 RLD DI mounting arrangement

3.2 Preparation

3.2.1 Cables

Table 10 defines the number of cores required for each function that is linked to the axis control. For example, fine quad, reference mark and error would require four pairs and a circuit ground or the inner screening if used, connected at the RLU only, to prevent an earth loop.

Table 10 Number of twisted pairs per function

Function	Format	Number of signals
Fine quad	RS422	2 pairs
Coarse quad or analogue	RS422 sine / cosine	2 pairs
Reference mark	RS422	1 pair
Error	RS422	1 pair
Sensors ¹	RS485	1 pair
0 V	Circuit ground	1
Connector screen	Case ground	-

The choice of cables for this application is very important, as the data rate can be high. The signal will degenerate as the length of the cable increases and as the signal frequency increases. To reduce the signal degradation, twisted pairs are recommended. Further reduction in degradation can be achieved by individual screening of the pairs.

Cable should be to at least the following specification:

- Twisted pairs
- Overall screen
- Low capacitance

Cable length/signal frequency considerations

In order to achieve reliable signal transmission, the correct type of cable and suitable values for line termination must be utilised.

In applications where more than five meters is required, it is recommended that a custom cable is manufactured. This should be manufactured from the following specification cable:

- 24 AWG EcoMini 2 pair
- Nominal diameter 4.22 mm (0.166")

An example of this cable is '**Alpha Wire**' - Manufacturers part number 78172.

This cables nominal diameter correctly fits the recommended Binder cable back shell clamp (maximum allowed diameter 5 mm).

¹ Do not connect unless you intend to connect temperature sensors directly to the RLU.

Digital signals

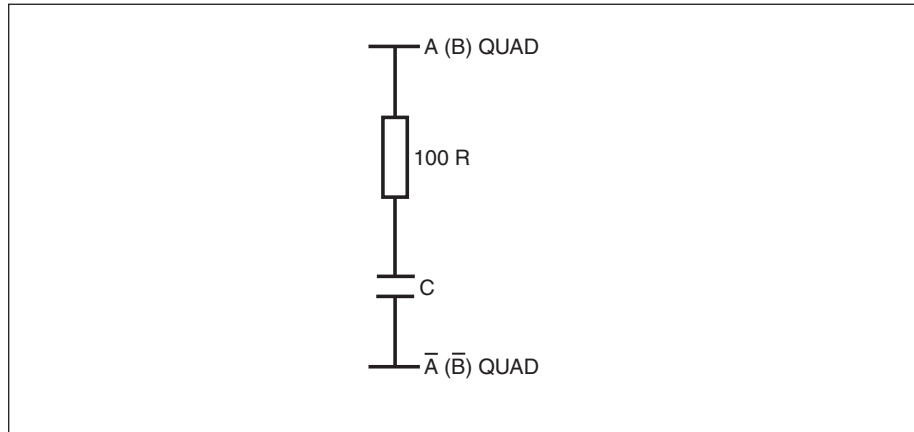

Figure 14 Cable termination (digital signals)

1. Determine the required cable length from the RLU to the controller or counter. Select the correct termination value from Table 11.

Table 11 Cable terminations

Length	Termination
< 1 m	100 pF + 100 R
> 1 m	1 nF + 100 R

2. Determine the maximum update rate which can be tolerated for the given length using table 12.

Table 12 Update rate

Update rate (MHz)	Maximum recommended cable length (metres)
20	10
10	20
5	45
2.5	100
1.25	200
0.625	400
0.3125	800

3. Set the update rate using the RLU configuration switches (see section 3.3). Ensure that this update rate does not limit the required velocity and that the RLU update rate is selected appropriately.

NOTE: Refer to the information on update rate versus feedrate and resolution in section 3.4 to calculate the maximum signal frequency.

Analogue signals

Termination is recommended as follows:

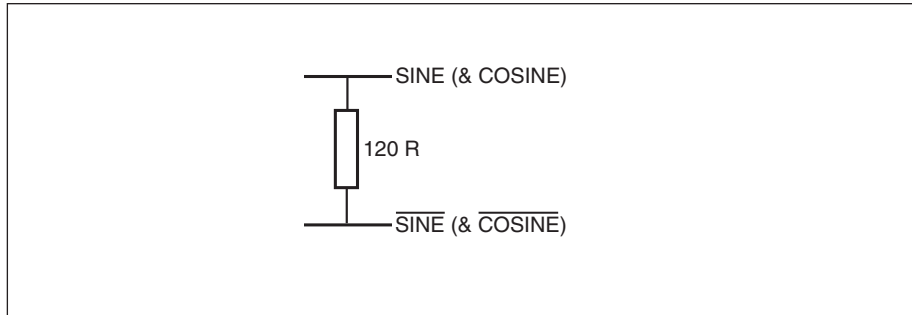

Figure 15 Cable termination (analogue signals)

A cable with individually screened twisted pairs is recommended, especially at high velocities.

NOTE: In order to achieve the specified SDE performance, use 1% tolerance termination resistors or better.

Recommended cables

Renishaw have performed trials with Belden cables and although other cables may meet the required specification, the recommended cables are given in Table 13.

Table 13 Belden cable range

Number of twisted pairs	OSC	OSC + ISC
2	8102	8162
3	8103	8163
4	8104	8164
5	8105	8165
6	8106	8166
7	8107	8167

OSC = outer braid screen

ISC = inner foil screen pairs

3.2.2 Reference mark switch

A reference mark input port is provided for each axis (REF AX1, REF AX2). This input may be used with any of the following:

- Switch (normally open)
- 5 V (active high)
- Solid state output

The switching thresholds for the opto input are: on by 3 V, off by 1 V.

Switch/solid state

A switch can be used across pins 1 and 2 with a link between pins 3 and 4 (see Figure 16) or conversely across pins 3 and 4 with a link between 1 and 2. Equally, the input may be switched either 'high side' or 'low side' by a solid state switch.

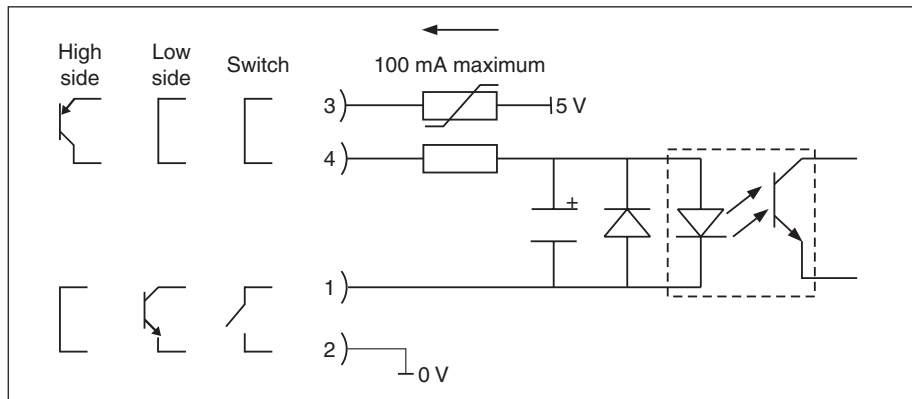

Figure 16 Reference mark switch (switch/solid state)

5 V

If a 5 V line is available, it can be used to trigger the reference on pin 4 with pin 1 being reference return.

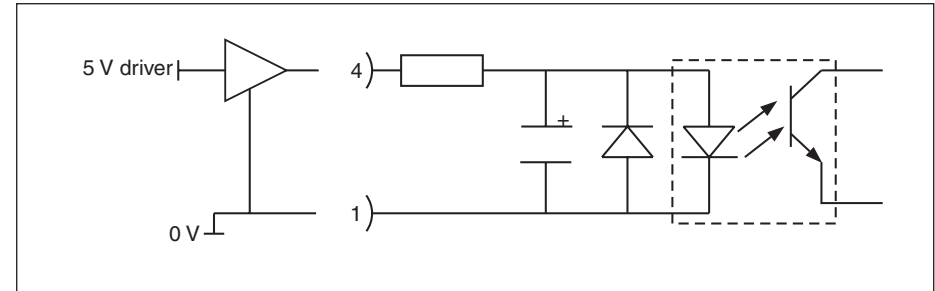

Figure 17 Reference mark switch (5 V)

CAUTION: If a voltage exceeding 10 V is applied across pins 1 and 4 on the connector, damage to the unit can occur.

A 5 V (100 mA max) supply is available from pin 3 with pin 2 as 0 V supply ground. This output is protected with a self-resetting fuse, which will trip if more than 100 mA is drawn.

Reference mark (Z) timing

A reference mark output will be produced from the RLE on the next cycle of A quad.

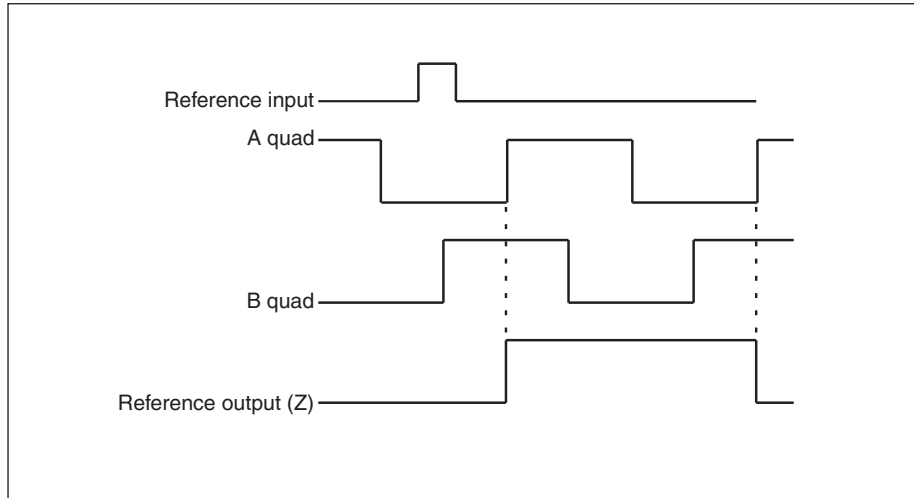

Figure 18 Reference mark (Z) timing

3.2.3 Error output signal

An error output signal is provided to enable detection of any failure in the encoder system by the machine control. This signal is of the RS422 format. (When active, error is high, /error is low.)

Table 14 Error output signal

Error	Output asserted	If switch 13 ¹ is on
Laser failure	Until fault cleared	-
Laser unstable	Until stable	-
Beam block	500 ms minimum ²	Latched
Overspeed	500 ms minimum ²	-
Beam low	No	-
Detector saturated	No	-



WARNING: The RLE fibre optic laser encoder continuously checks for any internal errors that may cause invalid position feedback signals, and signals a fault by asserting an error line output. In the case of closed loop motion systems, for safe operation the status of this error line must be monitored. If the error line is asserted, the position feedback signals may be incorrect and the axis of motion must be stopped.

NB: In the event of power loss from the RLE, error lines become inactive and the axis of motion must be stopped.

¹ Refer to section 3.3 for the location of the RLU configuration switches.

² If the error condition lasts longer than 500 ms then the error output line will clear 10 ms after the error condition is cleared.

3.2.4 Reset input

If switch 13 has been set such that beam block errors are latched, the reset input should be used to clear the error.

The circuit is as shown below. It may be used in a similar manner to the reference mark switch input (see section 3.2.2) with the addition of a 24 V input. The reset input is active high.

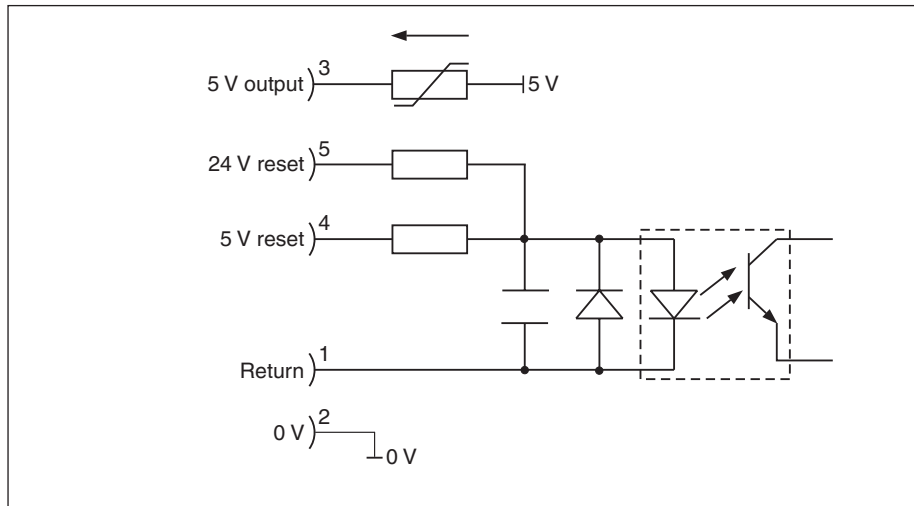

Figure 19 Reset input

3.2.5 Laser beam shutter

The RLU contains a laser beam shutter which may be activated via the shutter connector on the front panel of the RLU. The laser beam shutter blocks all laser light from being emitted from the RLU.

The input circuit is the same as for the reset input and is shown below. The shutter input is active high.

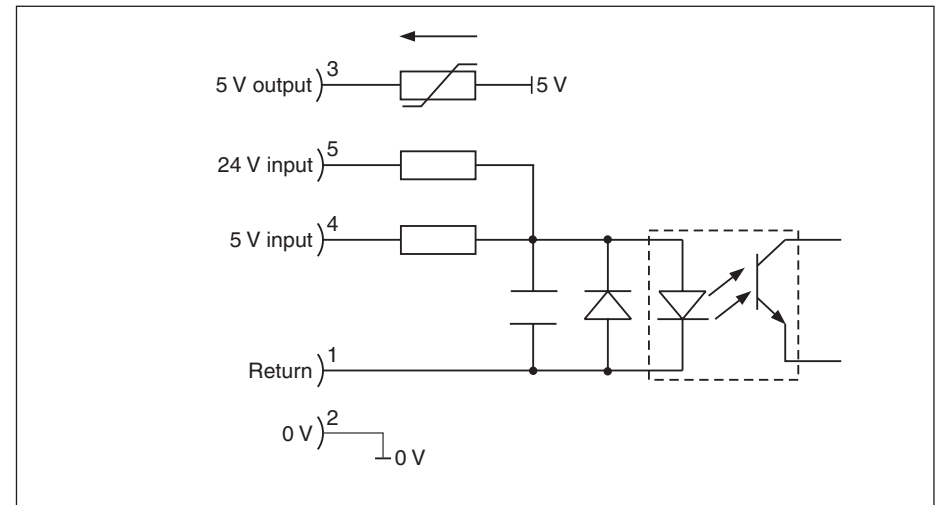

Figure 20 Shutter

3.2.6 RLD connections

Cable marking

When connecting the RLD units to the RLU, it is important to ensure that the RLD is fitted to the correct channel (AX1, AX2). This must be done because each RLD is matched at manufacture to a specific fibre output. The rating label on the back of the RLU details the serial number(s) of the RLD(s) and the axis to which they have been matched.



WARNING: Connection/disconnection between RLD units and the RLU should be made when the RLU is not powered. Failure to do this will initiate the interlock and may also cause damage to system electronics.

To assist with cable tracing, both the fibre conduits and the detector signal cable are marked at both ends with coloured markers as follows:

- Axis 1 Yellow '1'
- Axis 2 Red '2'

(On RLD DI heads, a coloured axis marker label is also fitted to identify the axis.)

Additionally, a set of white cable markers labelled 'A' are included with each system. These can be used to identify cables where two or three laser systems are used together.

Fibre connection

The fibre barrel must be inserted into the detector head in the correct orientation. To do this, align the white line on the barrel with the alignment dot on the detector head. Insert the barrel fully and then rotate it slightly either way until it can be felt to engage in the detent.

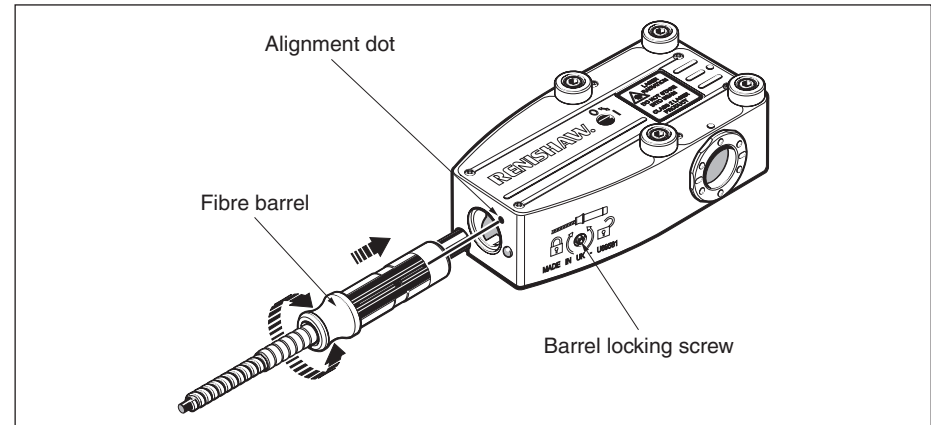

Figure 21 Fibre connection – RLD PMI, RRI and XX

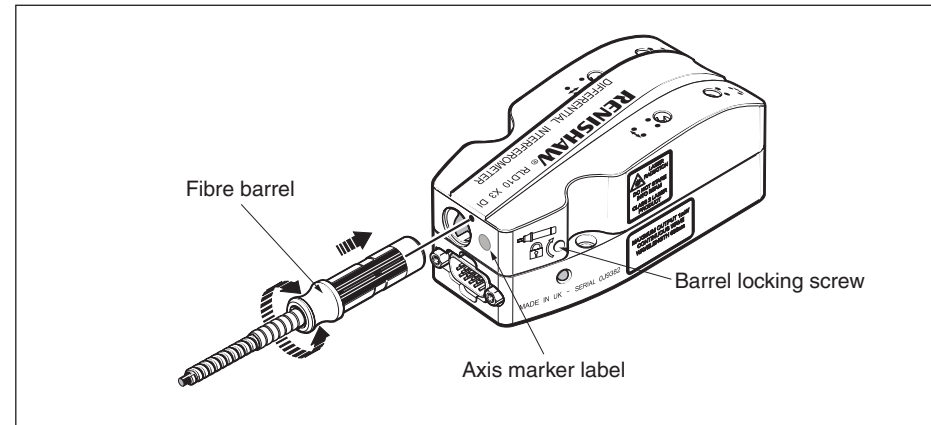

Figure 22 Fibre connection – RLD DI

Once the barrel is correctly inserted, it should be further secured by the barrel locking grub screw (M3 × 4 for the RLD PMI, RRI and XX and M3 × 6 for the RLD DI), which is not supplied fitted to the detector head, but can be found in the fixing kit. To lock the barrel in place, turn the grub screw clockwise until it grips the barrel, with a torque driver set to a maximum torque of 0.3 Nm. To release, turn counter-clockwise.

! **CAUTION:** Ensure the barrel locking screw is unlocked before attempting to insert or remove the barrel from the detector head. It is also important to ensure that the barrel screw is locked before commencing system alignment.

When the fibre is removed, the interlock in the detector head will activate the laser beam shutter inside the RLU. Once the fibre is reinserted, the laser beam shutter will open.

Electrical connection

! **CAUTION:** Before any electrical connections are made, ensure that the RLU and machine controller are unpowered.

The RLD electrical cable must be connected to the appropriate connector on the RLU (detector AX1 or AX2). To do this, remove the blanking cover from the RLU connector and connect the RLD cable. Finally, tighten the retaining screws.

If an RLD DI head is being installed, the user should also connect the detector head cable to the relevant detector head and tighten the retaining screws.

The RLU10 quadrature output cable must be connected to the machine controller.

NOTE: It is recommended that a differential receiver with high common mode rejection is utilised.

3.2.7 Operating the RLD shutter

RLD PMI, RRI and XX detector heads have a manually operated integrated shutter (the RLD DI does not have a shutter). In normal operation, the shutter slot on top of the detector head is turned to position '1', allowing the laser beam to pass. When the shutter slot is turned to position '0', the shutter is closed and the beam is obscured.

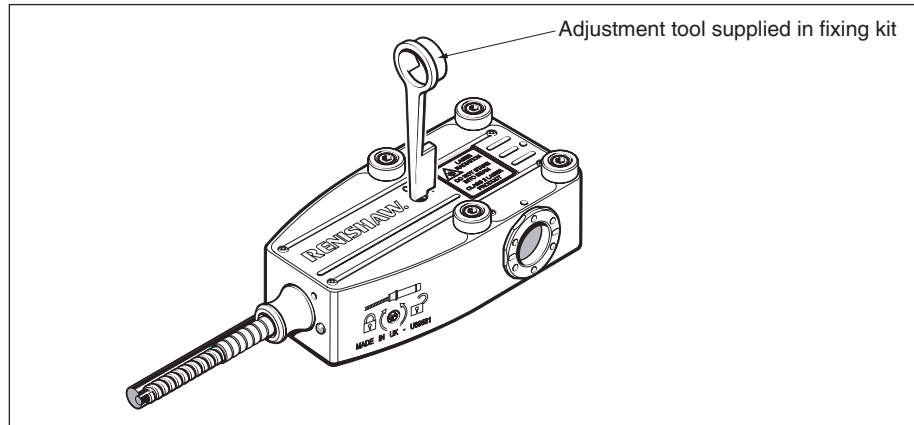

Figure 23 Operating the shutter

NOTE: PMI, RRI and XX systems will be supplied with the shutter closed. It must be opened before the system can be used.

3.3 RLU configuration switches

NOTE: The configuration switches are located beneath a cover.

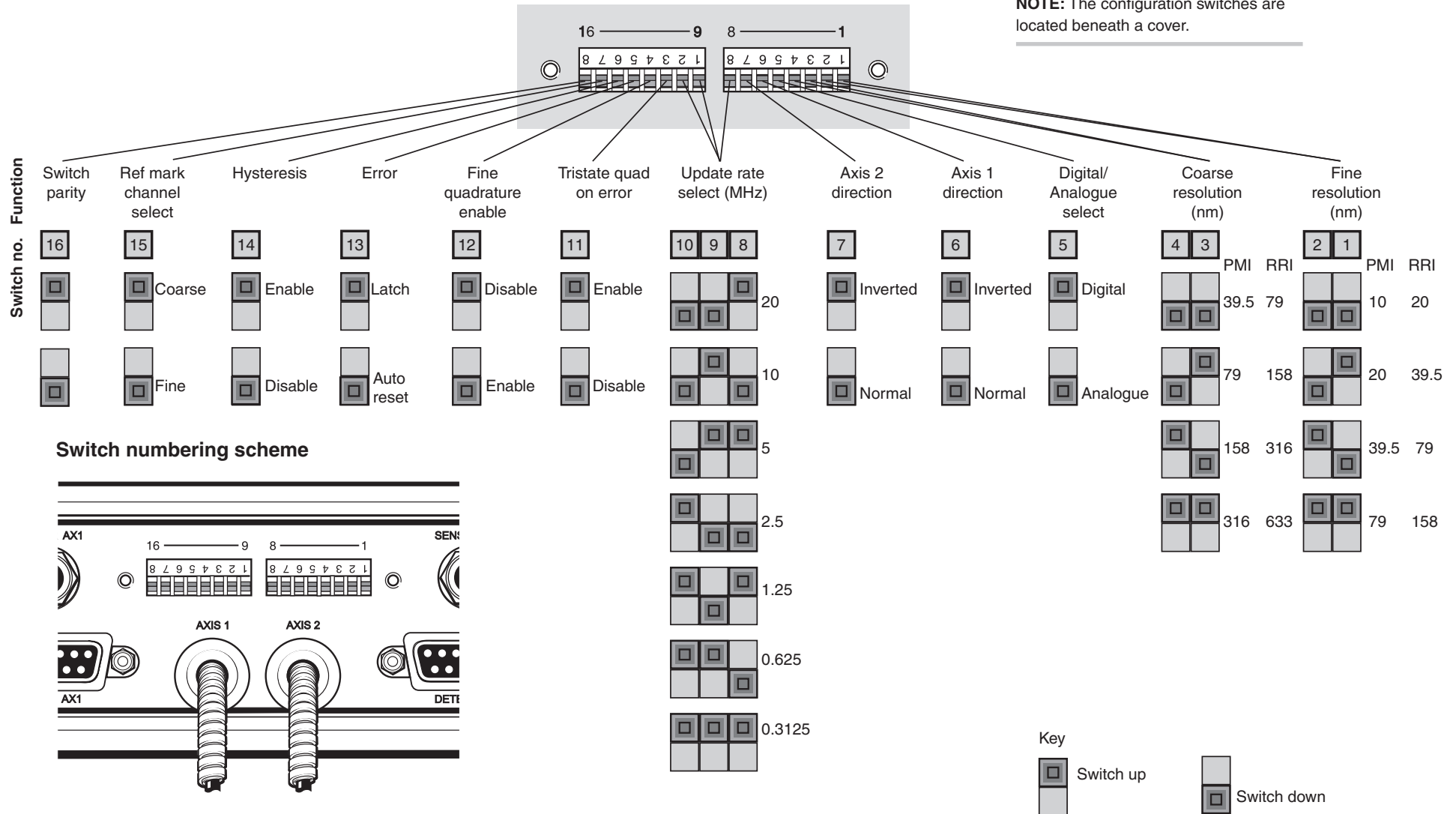

Figure 24 RLU configuration switches

3.4 Front panel switch information

Factory default setting

When initially supplied, the RLU switch cover has a caution label fitted across it, as shown on the right, and the configuration switches are set to the factory default as detailed in Figure 25. When refitting the RLU switch cover, use a torque driver set to a maximum torque of 0.3 Nm.

CAUTION
INTERNAL CONFIGURATION
SET TO FACTORY DEFAULT
CONSULT INSTALLATION GUIDE

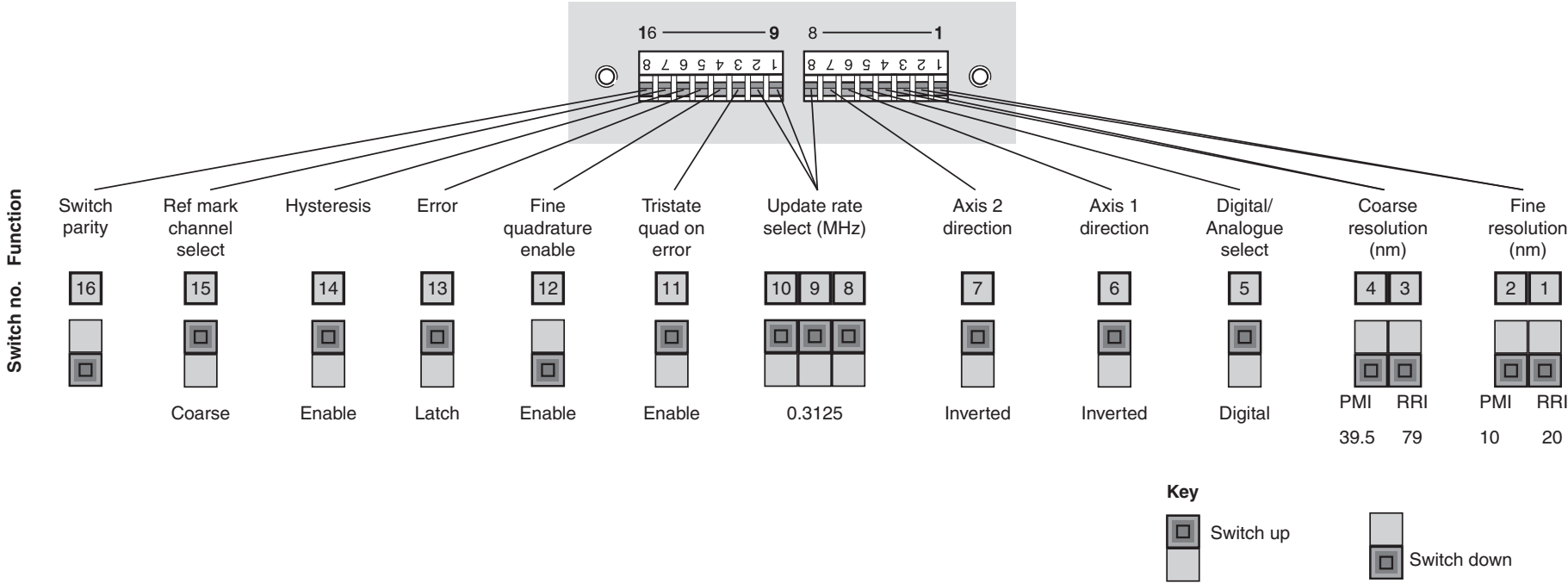

Figure 25 Default setting of configuration switches

Fine resolution (switches 1 and 2)

The digital output resolution (edge-edge separation) of the fine output may be selected.

Coarse resolution (switches 3 and 4)

The digital output resolution (edge-edge separation) of the coarse output may be selected.



WARNING: It is important to set the output resolution of the Renishaw system to match the controller's input resolution. If the quadrature resolution is set incorrectly, the axis may move for distances and at speeds that are not expected. For example, if the output resolution from the RLE system is set to half that of the controller input, the axis may move twice as far and twice as fast as expected.

Output format (switch 5)

The format of the coarse output may be selected between digital RS422 quadrature and analogue 1 V sinusoidal signals. If analogue output signals are selected, switches 3 and 4 have no effect.

Table 15 Output format

Switch 5	Fine quadrature	Coarse output
Up	Digital quadrature	Digital quadrature
Down	Digital quadrature	Analogue 1 Vpp

RLU output direction (switches 6 and 7)

Digital mode only

The direction (phase shift) of the output signals may be reversed independently for each channel using switches 6 and 7. Normal quadrature is considered as A leading B, with the measuring optic moving away from the RLD.

Table 16 RLU output direction (digital)

RLD configuration	Switch	Quad direction
90°	Up	Inverted
	Down	Normal
0°	Up	Normal
	Down	Inverted
DI ¹	Up	Normal
	Down	Inverted



WARNING: It is important to set the direction sense correctly. If it is set incorrectly, the machine will move in the opposite direction to that expected, and may accelerate until it reaches the axis limits. In the case of parallel twin rail drives, it is important that the direction sense of the slave axis is set to match the master axis. Failure to do this will cause opposite ends of the cross-member to move in opposite directions, possibly causing damage to the machine.

Analogue mode only

When analogue mode is selected, direction switches 6 and 7 are inoperative. Analogue quadrature phasing, with the measurement optic moving away from the RLD, is as shown in Table 17.

Table 17 RLU output direction (analogue)

Switch 5	Fine quadrature
90°	Cosine leads sine
0°	Sine leads cosine

Update rate (switches 8, 9 and 10)

The RLE fibre optic laser encoder allows the output update rate of the digital encoder output signals to be selected. If this update rate is set too low (below the count rate), the RLE will flag an overspeed error. If the update rate is set too high for the controller input bandwidth, the controller may miss some of the incoming pulses, resulting in a loss of feedback integrity.



WARNING: It is important that the output update rate of the RLE is set below the maximum input bandwidth of the controller.

$$\text{Update rate (MHz)} = \frac{\text{Maximum feedrate (m/sec)}}{\text{Output resolution } (\mu\text{m})}$$

Tristate quad on error (switch 11)

Rather than using an error line to send the error signal to the axis control, it is possible to use switch 11 to set the quadrature output lines to tristate (i.e. go into high impedance state), when the RLU detects beam block, overspeed or laser unstable. This function is useful when the control recognises a tristate condition but does not have an available error input.



WARNING: This function should not be enabled when the control is unable to detect this state.

Fine quadrature enable (switch 12)

This allows the fine quadrature (digital) output to be entirely disabled. This needs to be done in the case where the fine output is not being used and the axis velocity would cause an overspeed error.

Error latch (switch 13)

If an error is detected, the RLE will assert the error output line. The operation of this line can be selected to either latch, which requires an electrical reset to be applied, or non-latched, which self-resets one second after the error condition is removed.

Hysteresis (switch 14)

Electrical noise or axis vibration can cause multiple edges on the digital quadrature lines when passing through a transition. These multiple edges are caused by multiple transitions across the switching threshold within the analogue to digital converters from which the digital quadrature is directly derived. Edges may be produced even if there is no movement, due to noise being present within the vicinity of the switching threshold. These edges can occur at any frequency up to the output update rate.

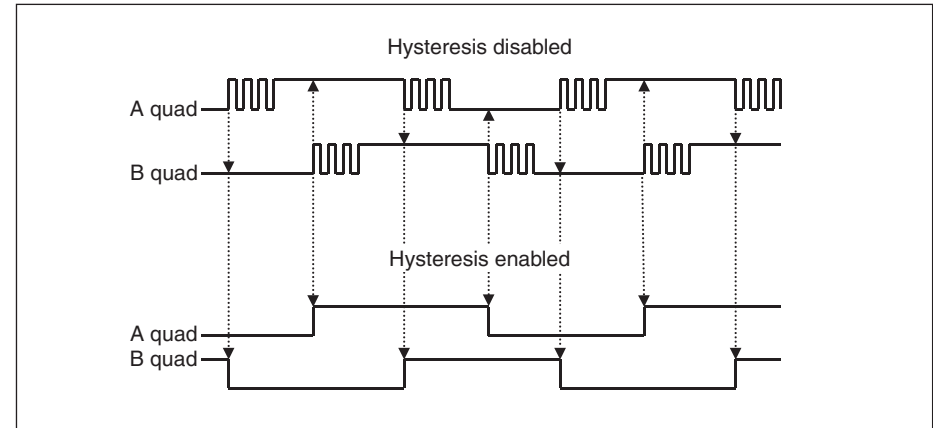

Figure 26 Hysteresis

This effect can be removed by including positional hysteresis on the quadrature outputs. This ensures that a transition can only occur once within one unit of resolution.

Switch 14 is used to enable hysteresis on all of the digital output lines (fine and coarse quadrature). In each case, a transition on the A line allows a change on the B line to be transmitted and vice versa.

This does mean that, when selected, this hysteresis function will introduce a one unit of resolution offset when a direction change is made.

Reference mark channel select (switch 15)

The reference mark operation may be selected to synchronise to either the coarse or fine output.

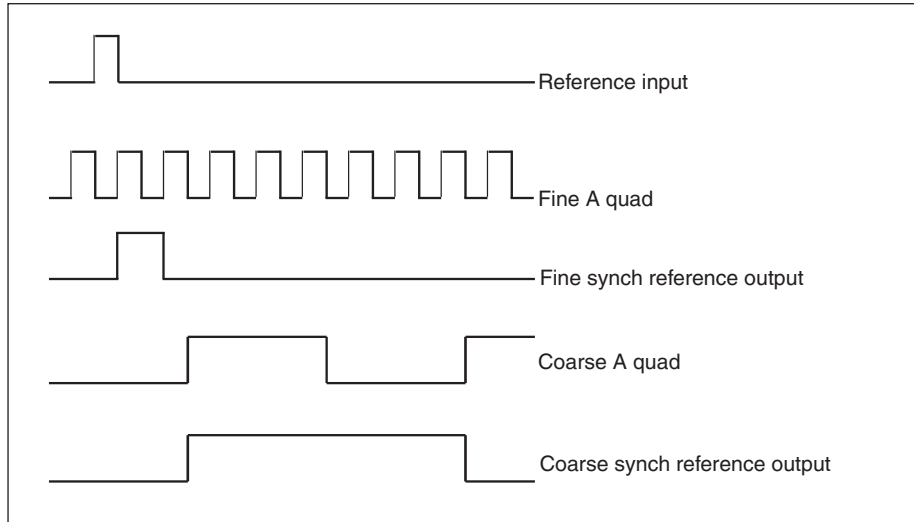

Figure 27 Reference mark operation

Switch parity (switch 16)

The parity switch has been included as a safety feature. It prevents the accidental mis-configuration of a single switch.

This switch must be used to maintain an even number of switches in the enabled position. If this switch is set incorrectly, an error will be asserted and the status LED will show red.

3.5 RLU laser unit mounting considerations

The laser unit may be mounted using either of the two methods shown in Figure 28.

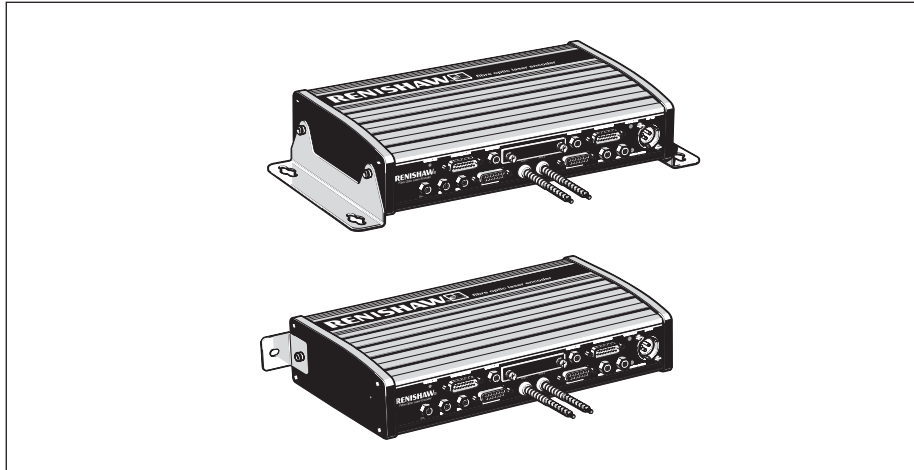

Figure 28 Mounting options

Two types of brackets and four M5 × 8 bolts are supplied.

CAUTION: The maximum length of the bolts used to fix the bracket to the laser must not exceed 8 mm.

Horizontal mounting brackets

When mounting on a horizontal surface, there are two main considerations. Firstly, the mounting surface must be flat and parallel to the RLU within 0.5 mm. Secondly, the supplied mounting brackets must be used to ensure that the correct air flow is maintained around the unit. When fixing the laser, tighten the bolts securing the brackets to the surface first, and the laser to bracket bolts second. This will avoid twisting the laser enclosure.

Vertical mounting brackets

When using the vertical mounting brackets, ensure that adequate space is left around the laser for air flow. Similarly, tighten the bracket to surface bolts first, followed by the laser to bracket bolts.

Fibre considerations

The protective metal conduit will protect the fibre optic cables in most situations. However, the clearance allowance and minimum bend radii should be observed for both the RLU and the RLD units (see Figures 7, 8, 9, 10 and 12).

3.5.1 Front panel

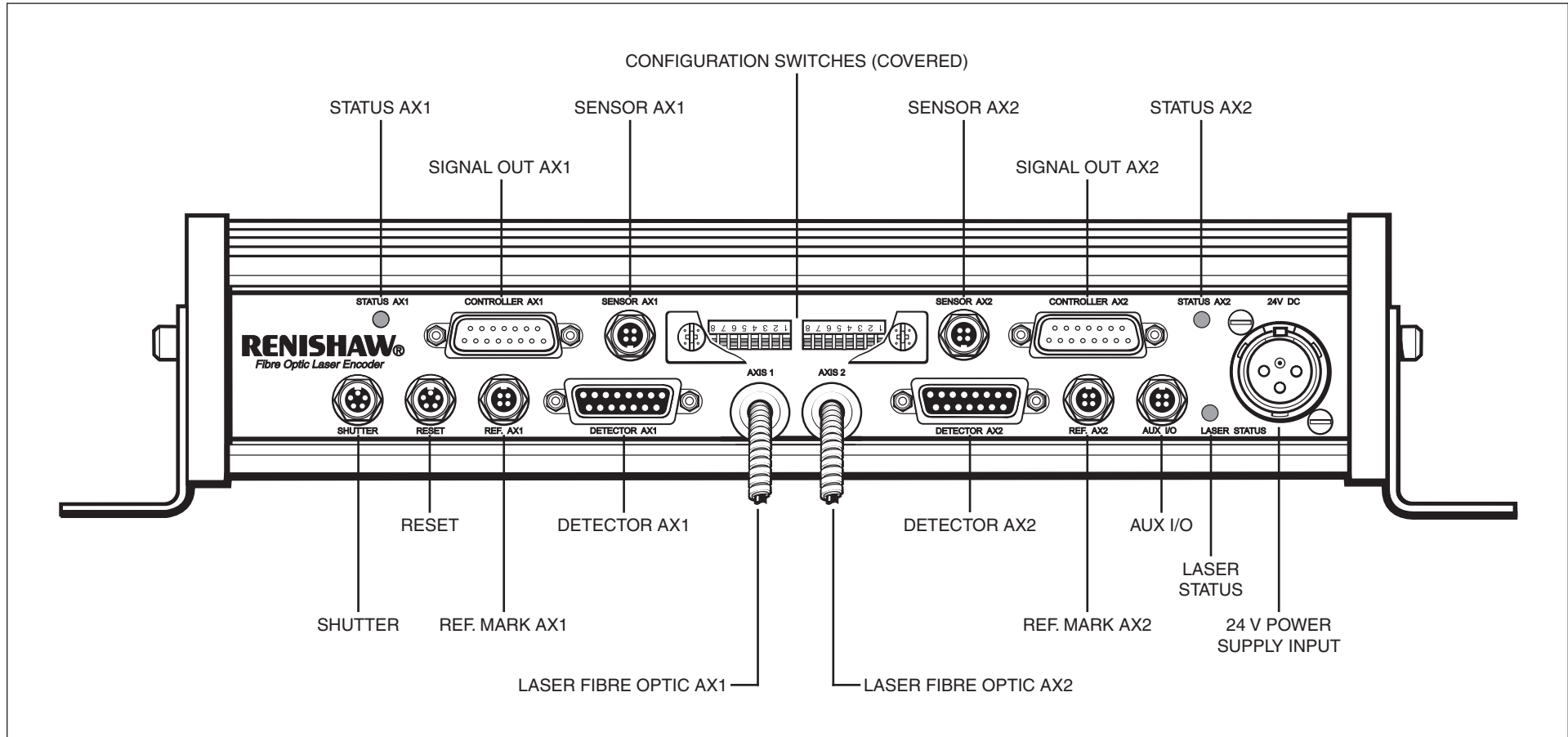

Figure 29 Front panel

3.5.2 RLU indicator LED information

Table 18 LED status

LED status	AX1 and 2 status	Laser status
Off	No power	No power
Continuous green	OK	Laser stable
Flashing green	Axis at reference	-
Amber	Beam low ¹	Laser unstable
	Detector saturated ²	
Red	Beam block ³	Laser failure
Flashing red	Overspeed	-

RLD power indication

The RLD also has a power LED. This should be green, indicating that it is receiving power when connected to the RLU.

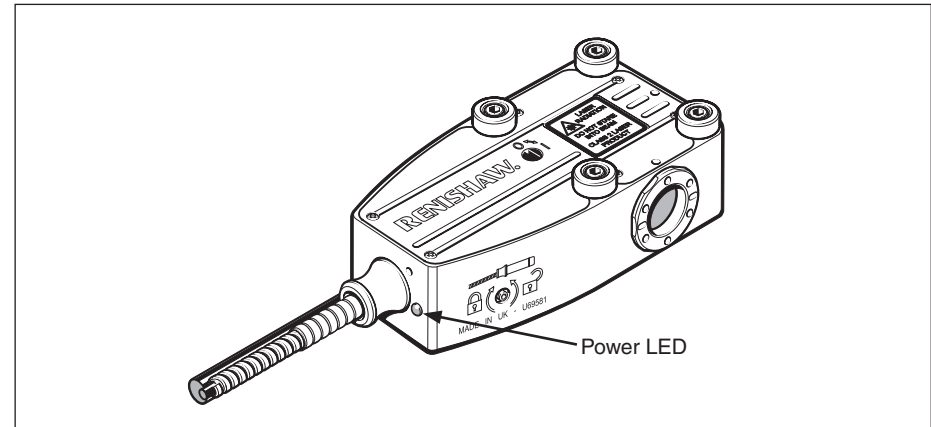

Figure 30 Power LED on RLD PMI, RRI and XX variants

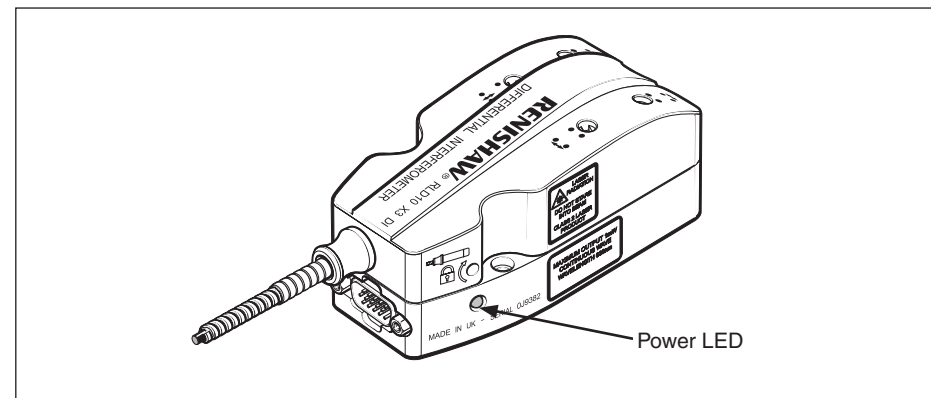

Figure 31 Power LED on RLD DI variant

¹ Beam low occurs from 12.5% to 25% signal.

² Signal has exceeded 120%. This may cause measurement errors in the fine quadrature or analogue outputs. Coarse quadrature will be unaffected.

³ Beam block occurs from 0 to 12.5% signal.

3.6 Alignment general

3.6.1 Adjustment methods

PMI, RRI and XX variants

The following methods of adjustment are available and are sufficient to align a system:

Translation adjustment

This can be done on the RLD by loosening all four fixing screws. ± 1 mm of translation is available. The retroreflector can also be translated by ± 1 mm.

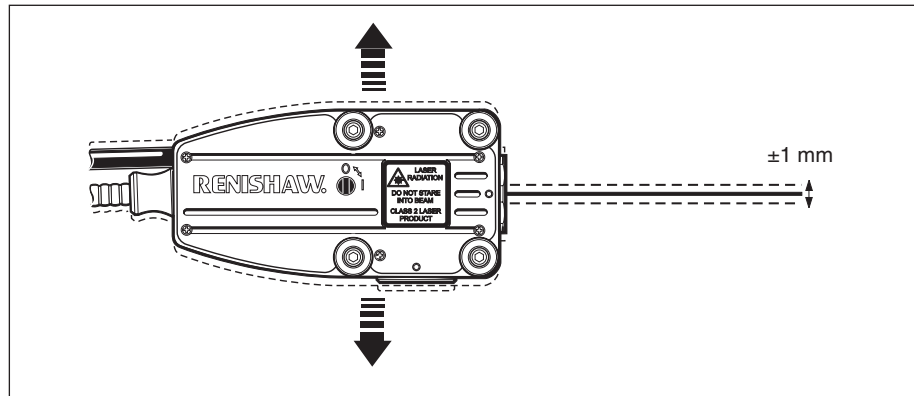

Figure 32 Translation adjustment

Rotation adjustment

Pitch

This can be performed with the built-in beam steering wedge. The wedge may be rotated by $\pm 25^\circ$ using the removable adjustment key, giving approximately $\pm 0.65^\circ$ beam movement.

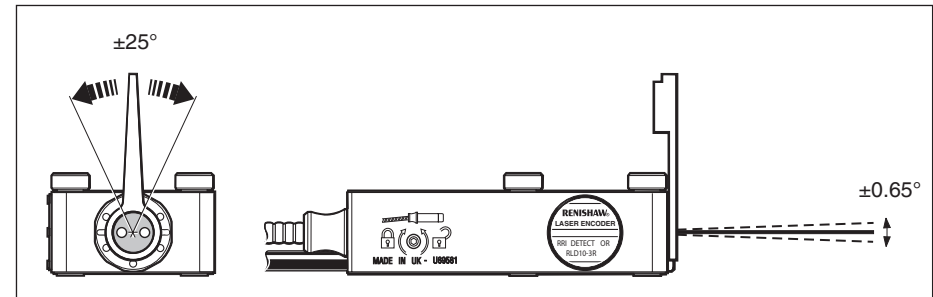

Figure 33 Pitch adjustment

Yaw

To apply yaw adjustment to the RLD, choose one of the front fixing screws as the rotation point – leave this semi-tight. Loosen the remaining three screws and tap the RLD lightly to rotate. Tighten the screws when complete.

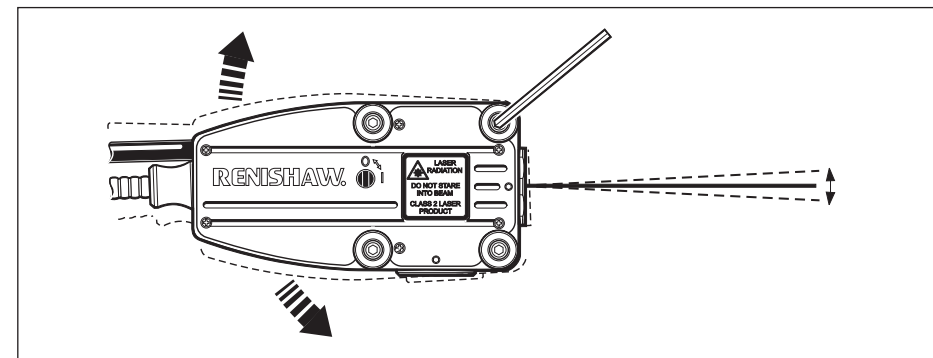

Figure 34 Yaw adjustment

DI variant

The RLD DI detector head contains four integrated beam steerers so that both pitch and yaw adjustments of up to $\pm 1^\circ$ can be made independently on the measurement and reference beams.

To perform alignment, the user simply adjusts the four controls on the back of the RLD DI with a torque driver set to a maximum torque of 0.2 Nm. The function of each of the controls is shown in figure 35.

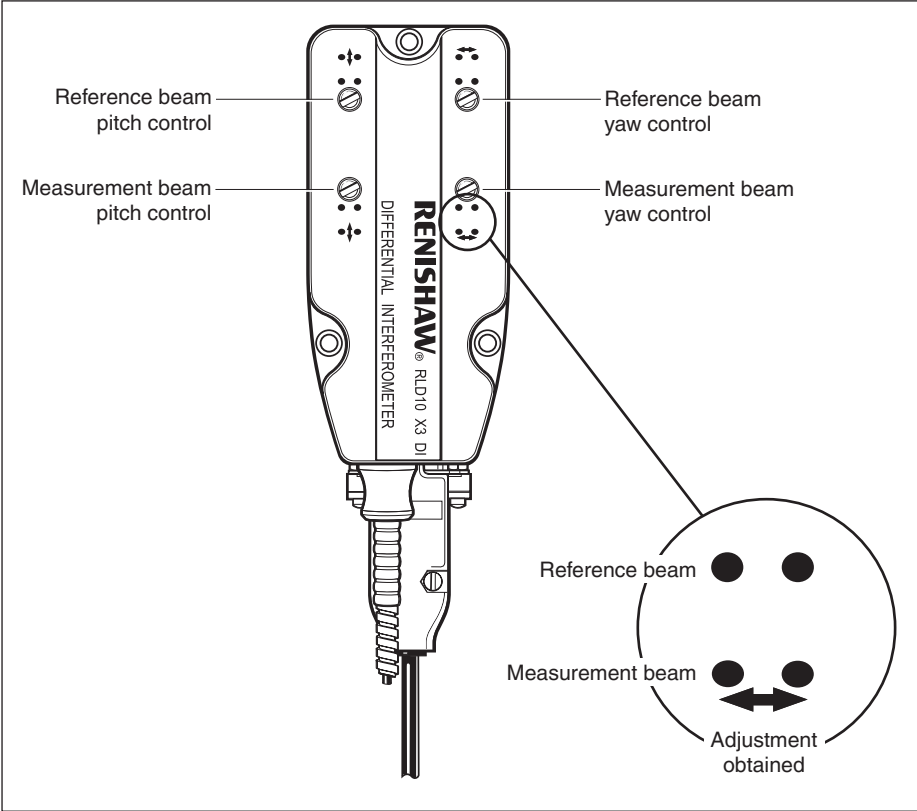

Figure 35 RLD DI pitch and yaw adjustment

3.6.2 Signal strength

The signal strength can be monitored via the auxiliary port, using a multimeter with 2 V DC range. The connector pinout is given in Table 25 on page 62.

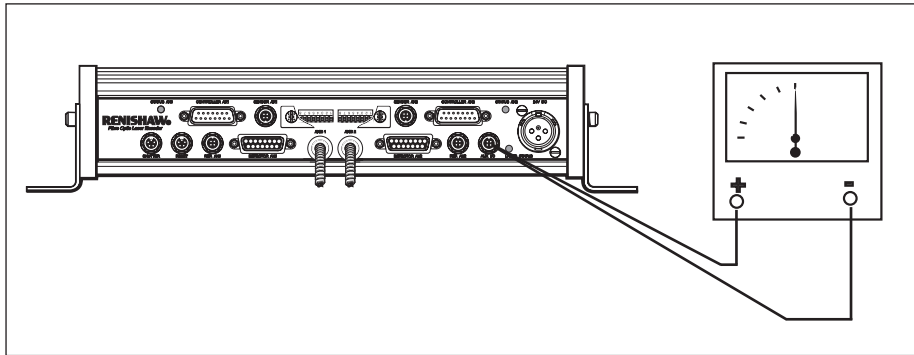

Figure 36 Signal strength meter

Table 19 Signal strength

Voltage (AUX I/O)	%	Condition	LED indication
1.00 V	>120%	Saturation	Amber
0.25 V - 1.00 V	25% - 120%	Maximum	Green
0.125 V - 0.25 V	12.5% - 25%	Beam low	Amber
0 - 0.125 V	0% - 12.5%	Beam blocked	Red

For optimum performance, the system should be set up to achieve signal strength between 25% and 100%. The system will function between the signal strength ranges of 12.5%–25% and 100%–120% but it may not achieve full accuracy. The system is not meant to function below 12.5% and will assert the error output.

! CAUTION: If the laser beam is misaligned, the error line will be asserted due to low signal strength. Also, if the laser beam is misaligned such that the return beam enters the laser output port, it is possible that the laser will be destabilised. This is normal behaviour, and again the error line may be asserted. Under either circumstance the laser position feedback signals may be invalid. For this reason, initial beam alignment must be performed with the machine under manual or open loop control.

NOTE: For XX variants, it may not always be possible to achieve 100% signal strength. When supplied, XX heads are matched to a standard interferometer during assembly. Therefore, depending on the optics used to achieve 100% signal strength, system matching in accordance with 'B.4 system matching' may be required (see page 71).

3.6.3 Alignment aids

PMI, RRI and XX variants

Two types of alignment aid are included with the detector head. Firstly, a set of target stickers which may be affixed to the retroreflector or moving machine element to assist in alignment. Secondly, a metal target which may be folded into shape and inserted under the detector to aid in plane mirror alignment.

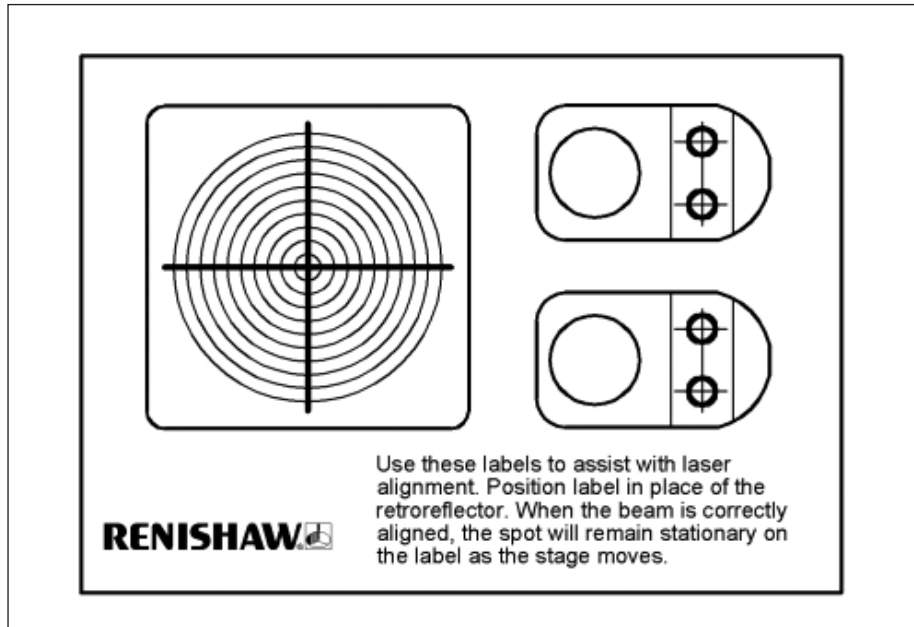

Figure 37 Alignment target stickers

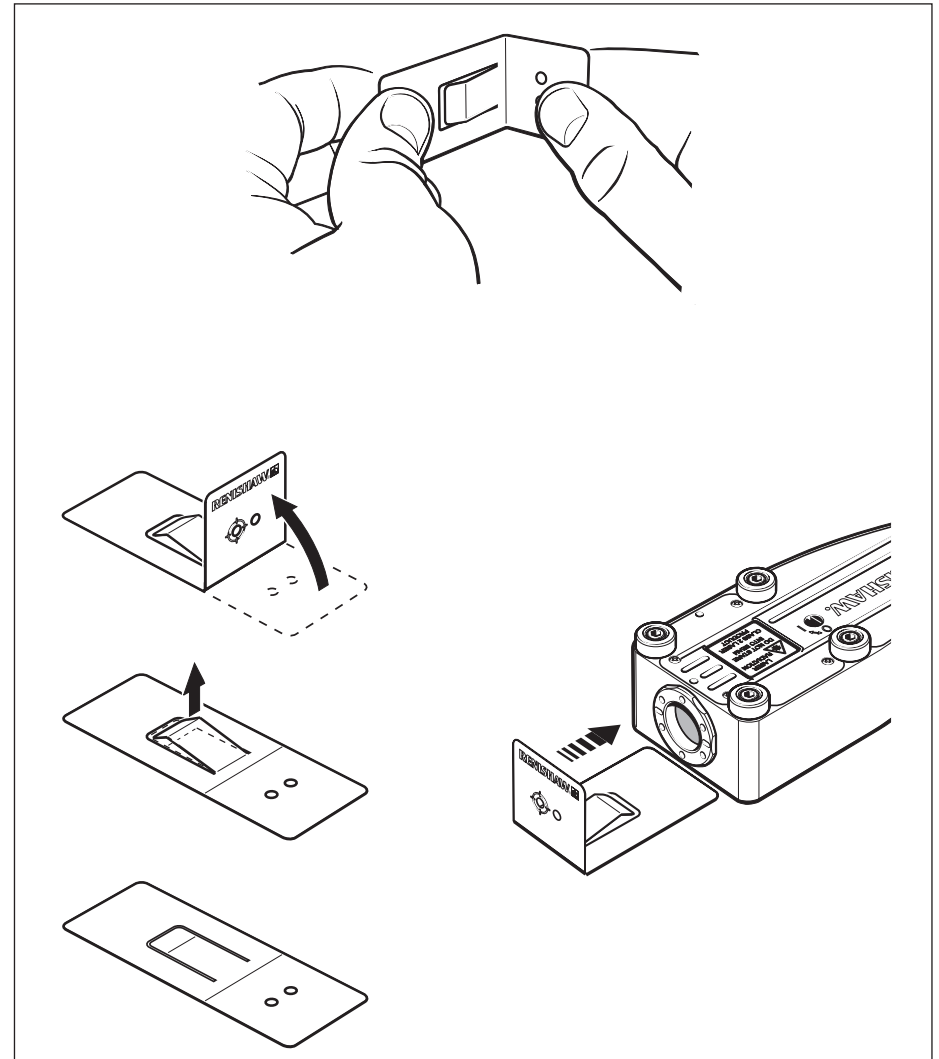

Figure 38 Metal target

DI variant

An alignment aid is available which enables beam alignment to be carried out with the chamber lid in place (ie. no direct line of sight to the mirrors). The alignment aid is temporarily fitted between the detector head and the mounting pins using the M3 x 25 screws supplied.

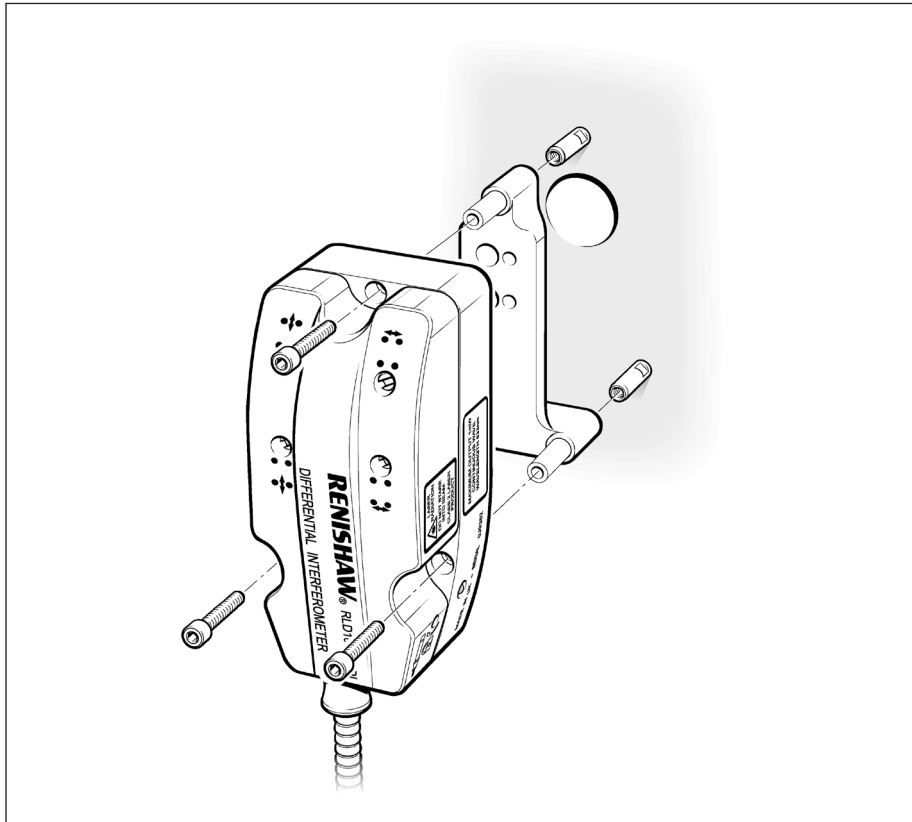

Figure 39 Alignment aid for DI variant

3.6.4 Retroreflector alignment process

Prior to alignment, ensure the beam steerer locking screws have been fitted but are not tightened. These locking screws (M3 x 3) can be found in the RLD10 fixing kit provided with each detector head. Ensure that the optical and electrical cables have slack to allow for head movement during alignment.

Ensure that the grooves on the beam steerer are in the horizontal position as shown in Figure 40.

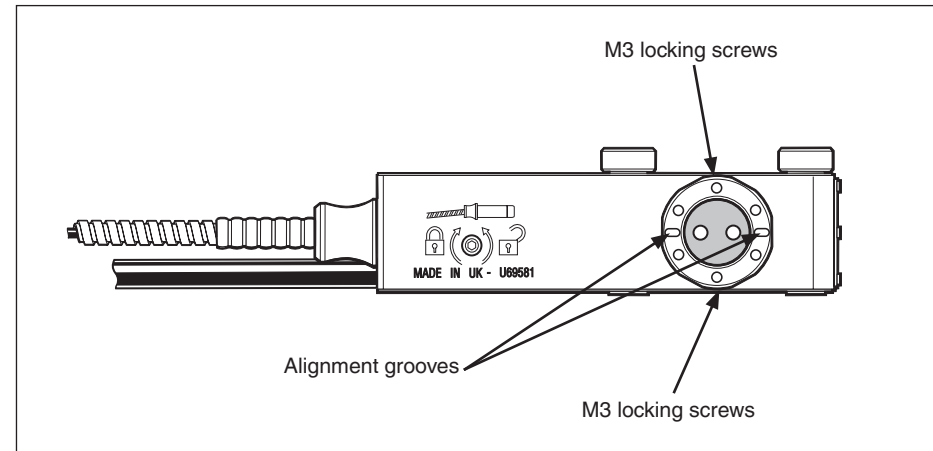

Figure 40 Position of alignment grooves

For the following alignment process, use the following rule:

- Apply only translation adjustments in the near field
- Apply only rotation adjustments in the far field

1. Fit the RRI detector head in position on the machine.
2. Attach the retroreflector to the moving part of the axis.
3. Alignment targets are supplied, which attach to the retroreflector with low tack adhesive, and can be used to monitor the outward beam. Stick an alignment target over the retroreflector.
4. Connect a voltmeter (2 V DC range) to the RLD connector (AUX I/O) with a signal strength cable (not supplied).

Near field adjustment

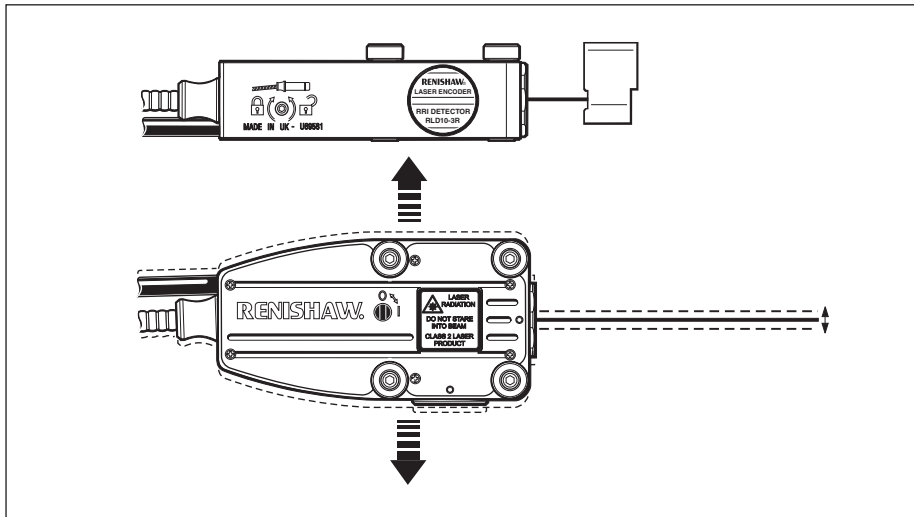

Figure 41 Near field adjustment - translation

5. When the retroreflector fixings are slackened, there is approximately 2 mm of translational adjustment. In addition to this the detector head has approximately 1 mm of translational adjustment when the fixing screws are loose.
6. Move the axis into the near field and, using the available translation, position the retroreflector so the beam hits the target correctly.

Far field adjustment

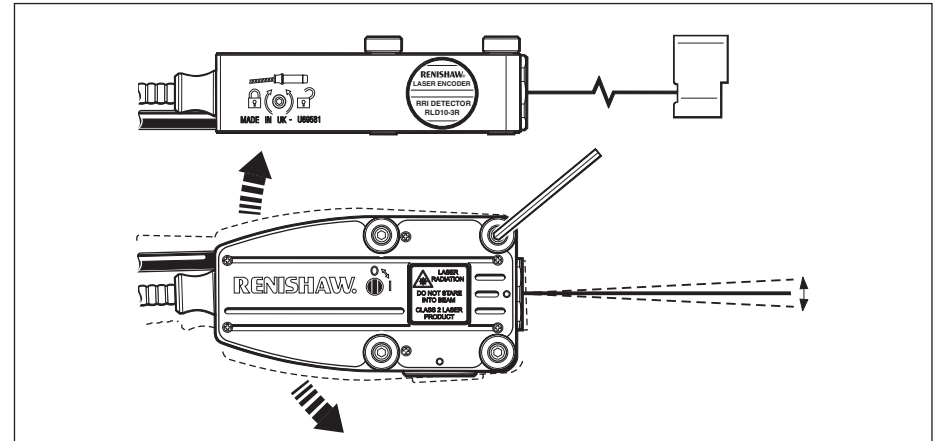

Figure 42 Far field adjustment – yaw only

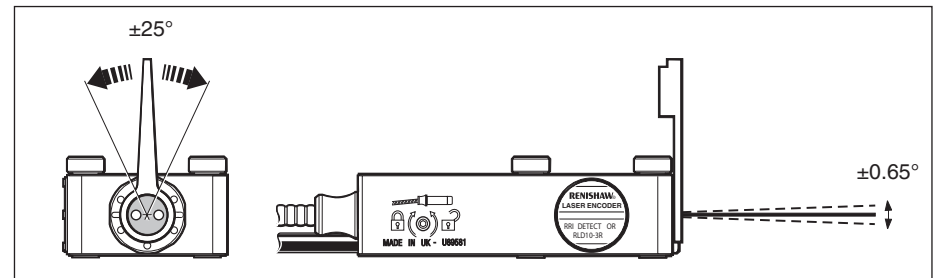

Figure 42a Far field adjustment - pitch only

7. Move the axis into the far field and, using pitch and yaw rotations, align the beam onto the target. (It is important that retroreflector translation is only used in the near field.)
8. Repeat steps 6 and 7 until a consistently aligned beam is obtained.
9. Finally, remove the target sticker and check the alignment over the whole axis length and ensure that a consistent signal strength is obtained.
10. Tighten the beam steerer locking screws (not exceeding a torque of 0.25 Nm) and ensure that the cables are strainrelieved to the mounting surface.

3.6.5 Plane mirror alignment process

Prior to set-up, ensure the beam steerer locking screws have been loosened or removed from the detector head. The locking screws should be fitted onto the top face once alignment is complete to prevent the beam steerer from moving further. These grub screws (M3 × 3) can be found in the RLD10 fixing kit provided with each detector head. Also ensure that the cables are strain-relieved to the mounting surface (this can be done after alignment is complete).

Also ensure that the grooves on the beam steerer are in the horizontal position as shown in Figure 43.

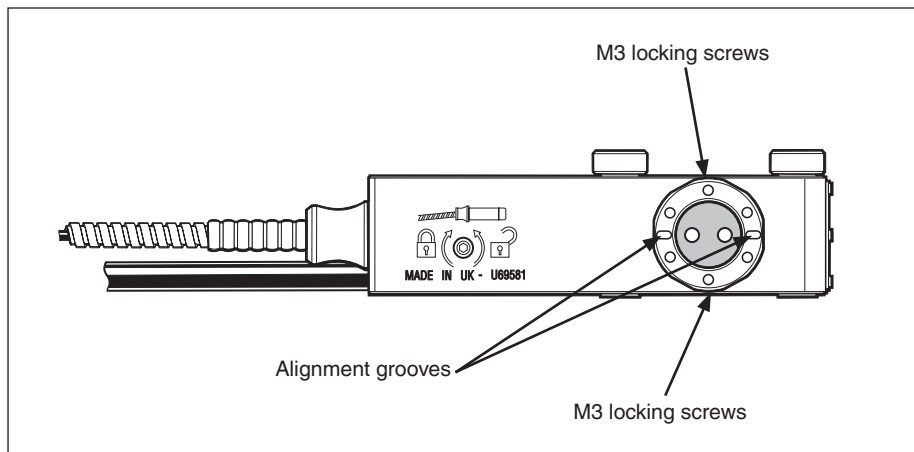

Figure 43 Position of alignment grooves

It is assumed that the plane mirrors have already been aligned perpendicular to axis motion, and orthogonal to each other if it is an XY application.

NOTE: For a more detailed alignment procedure refer to data sheet L-9904-2446.

Alignment

1. Mount the PMI detector head to the machine and roughly align the beam parallel to the axis of travel.
2. Move the axis to its furthest travel from the detector head.
3. Using the metal target provided (see Figure 38 on page 50), align the beam into the target aperture by adjusting only the pitch and yaw of the detector head.
4. Remove the targets and make fine adjustments to maximise the signal strength (see section 3.6.2).
5. Tighten the beam steerer locking screws (not exceeding a torque of 0.25 Nm) and ensure that the cables are strainrelieved to the mounting surface.

3.6.6 Differential interferometer alignment process

It is assumed that the following preparation has been completed:

1. The detector head mounting pins have been fitted.
2. The plane mirrors have already been aligned perpendicular to axis motion, and orthogonal to each other if it is an XY application.
3. Wait until the electrical connection is in place, the RLU stable, and has been powered on for at least 40 minutes.

NOTE: For a more detailed alignment procedure, refer to data sheet L-9904-2446.

DI head alignment using alignment aid

An alignment aid is available which enables beam alignment to be carried out if there is no direct line of sight to the mirrors.

The DI head has four torque driver slot controls on the back. The upper two adjust the pitch and yaw of the reference beam and the lower two the pitch and yaw of the measurement beam. This is denoted by the symbols next to each control.

NOTE: When adjusting the steerers use a torque driver set to a maximum torque of 0.2 Nm.

1. Before inserting the barrel into the detector, centralise all four beam steerers so that the steering wedges appear as shown in Figure 44. Move the measurement mirror as close to the detector as possible.

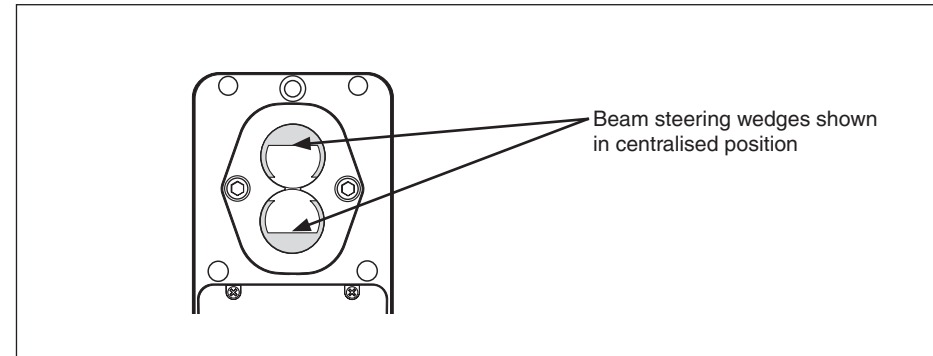

Figure 44 Steering wedges in centralised position

2. Fit the alignment aid between the chamber and the DI head, as shown in Figure 45, using the three M3 × 25 screws provided in the alignment aid kit and tighten to 0.6 Nm.

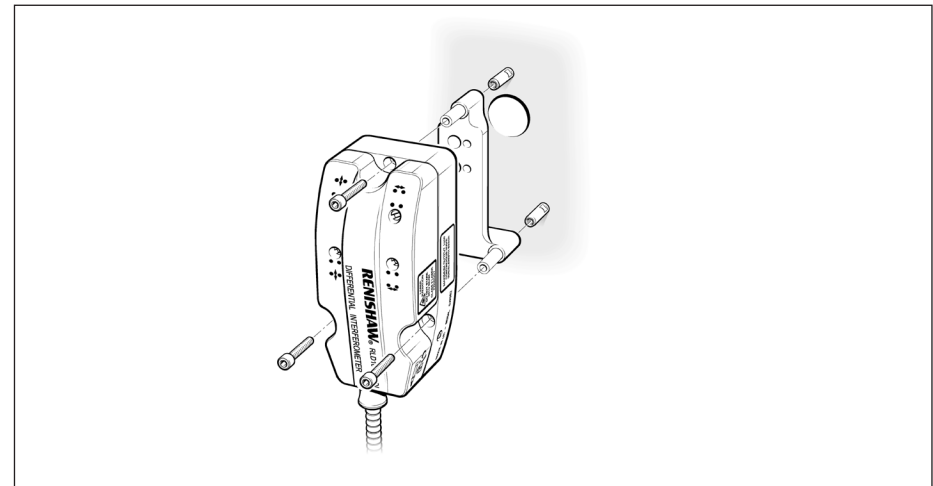

Figure 45 Alignment aid

- Referring to Figure 22 (on page 36), fit the fibre barrel into the detector head. Prior to alignment, ensure that the barrel clamp screw is tightened.
- Referring to Figure 46, using a suitable screwdriver, use the reference and measurement beam yaw controls to move the beams so that they are visible on the 45° slope at the left-hand side of the alignment aid.

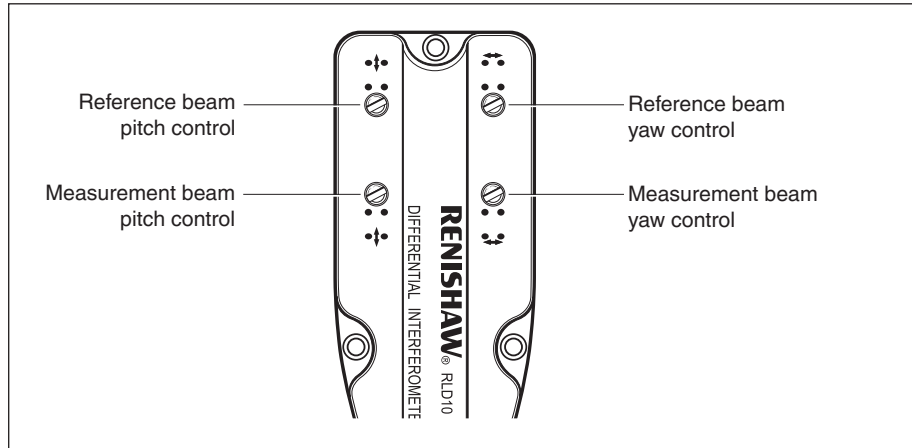

Figure 46 Pitch and yaw controls

- Referring to Figure 47, use the reference beam pitch and yaw controls to bring the reflected reference beam so that it passes through hole A in the alignment aid.

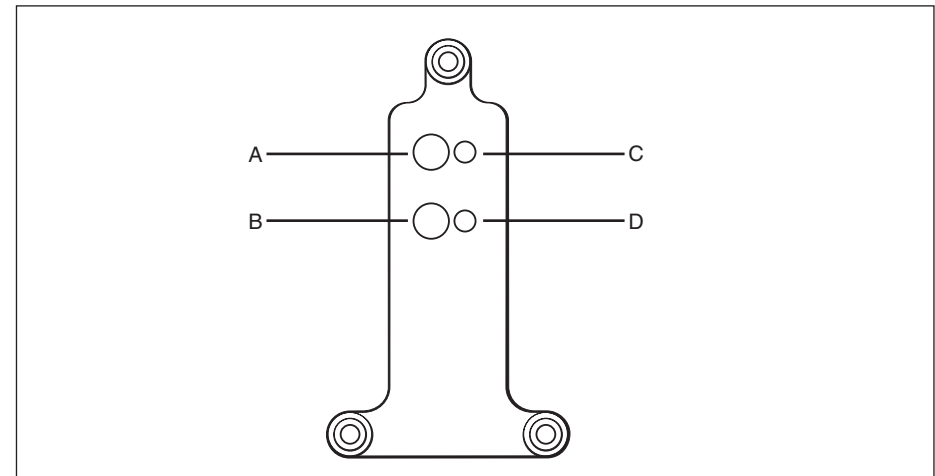

Figure 47 Alignment aid viewed towards chamber

- Repeat the procedure in paragraph 5 using the measurement beam pitch and yaw controls to bring the reflected measurement beam so that it passes through hole B in the alignment aid.
- Place an opaque piece of card against the chamber wall so that any beams passing through holes C and D in the alignment aid will fall on the card (do not block holes A and B).
- Use the reference beam pitch and yaw controls to move the reference beam until a full bright spot is visible beneath hole C.
- Repeat the procedure in paragraph 8 to move the measurement beam beneath hole D.
- Remove the card and, if the beams are now visible on the 45° slope at the right-hand side of the alignment aid, use the controls to move them into holes C and D.
- Make fine adjustments using all four controls to maximise the signal strength (see section 3.6.2).
- Unbolt the detector head and remove the alignment aid. Take care as laser beams will be emitted from the detector. Avoid shining into the eyes.

13. To minimise the effects of air turbulence, fit the air turbulence gasket over the three pins as shown in Figure 48.

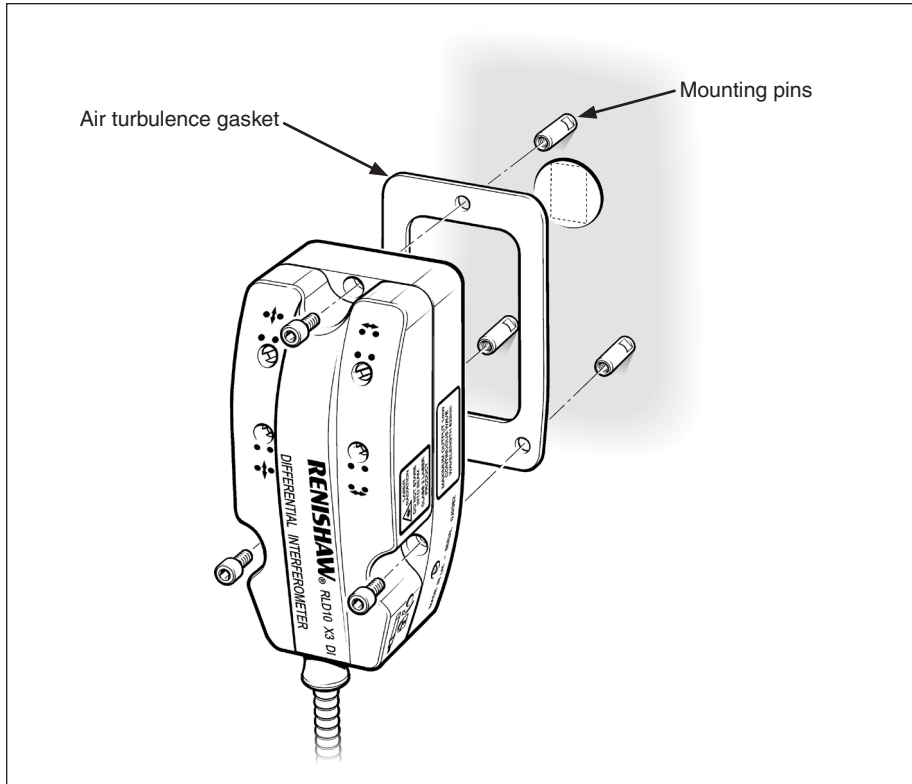

Figure 48 Air turbulence gasket

14. Refit the detector head to the chamber wall using the three M3 × 8 screws provided in the fixing kit. Tighten the screws to 0.6 Nm.
15. Check that signal strength has been maintained. It may be necessary to repeat the fine adjustments to maximise signal strength.

16. Finally move the measurement mirror to its furthest position from the DI head and check the signal strength. It may be necessary to adjust each control more than once in order to maximise signal strength.

NOTE: If the chamber to which the detector head is attached is subject to bakeout, it is advisable to remove the detector head before bakeout commences. Refer to the environmental specification in ['Appendix D - Specifications'](#).

4. Connector pinouts

All pinouts for axis 1 are identical for axis 2. The gender is quoted for the mating connector which connects to the RLU. When fitting the connector to the RLU, ensure that the connector screws do not exceed a torque of 0.4 Nm.

Table 20 Signal out AX1 and AX2 to controller (15-way D-type female)

Pin number	Function	
	Digital output selected	Analogue output selected
1	0 V DC	0 V DC
2 ¹	RS485 data (sensors)	RS485 data (sensors)
3	Error	Error
4	Z pulse	Ref mark
5	Coarse B quad	Sine
6	Coarse A quad	Cosine
7	Fine B quad	Fine B quad
8	Fine A quad	Fine A quad
9 ¹	RS485 /data (sensors)	RS485 /data (sensors)
10	/Error	/Error
11	/Z pulse	/Ref mark
12	/Coarse B quad	/Sine
13	/Coarse A quad	/Cosine
14	/Fine B quad	/Fine B quad
15	/Fine A quad	/Fine A quad
Shell	Chassis ground	Chassis ground

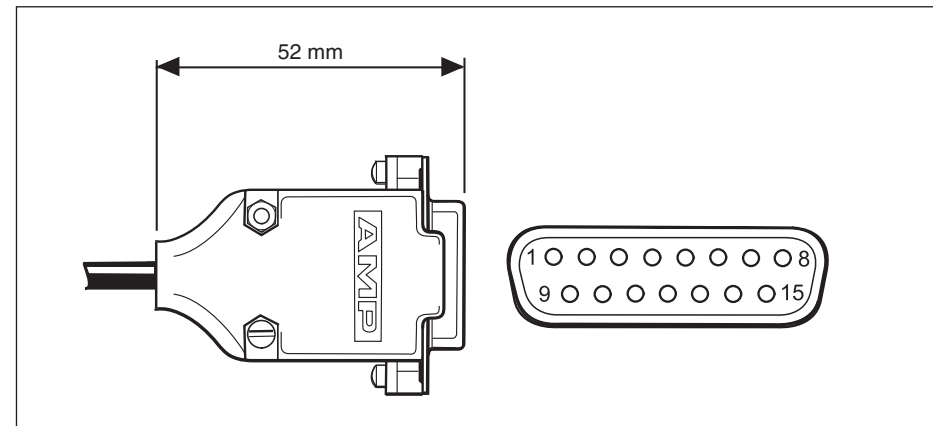

Figure 49 Signal out AX1 and AX2 to controller (15-way D-type female connector)

NOTE: This connector is viewed from the wiring side.

¹ Do not connect unless you intend to connect temperature sensors directly to RLU.

Table 21 24 V power supply input (standard XLR 3-way female)

Pin number	Function
1	24 V
2	+ Sense
3	Ground
Shell	Chassis ground

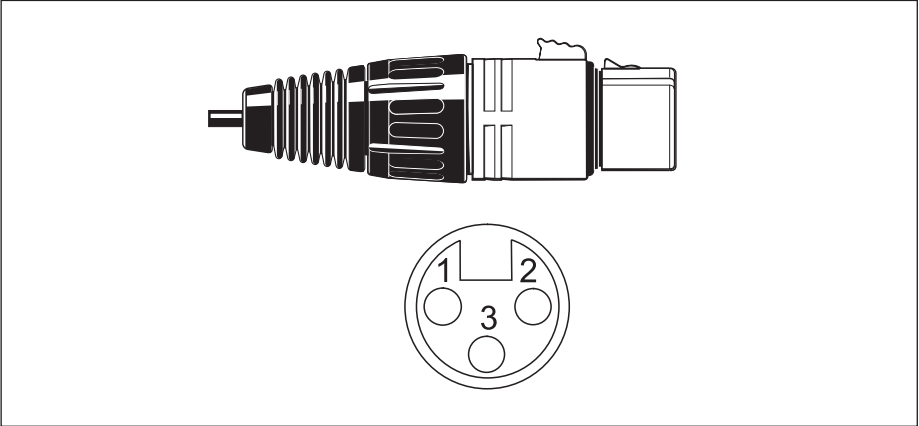

Figure 50 24 V power supply input (standard XLR 3-way female connector)

NOTE: This connector is viewed from the wiring side.

Table 22 Reference mark AX1 and AX2 (4-way binder 712 male)

Pin number	Function
1	Reference return
2	0 V supply ground
3	5 V supply
4	Reference input
Shell	Chassis ground

When switch is made, the Z pulse remains high for four quad counts.

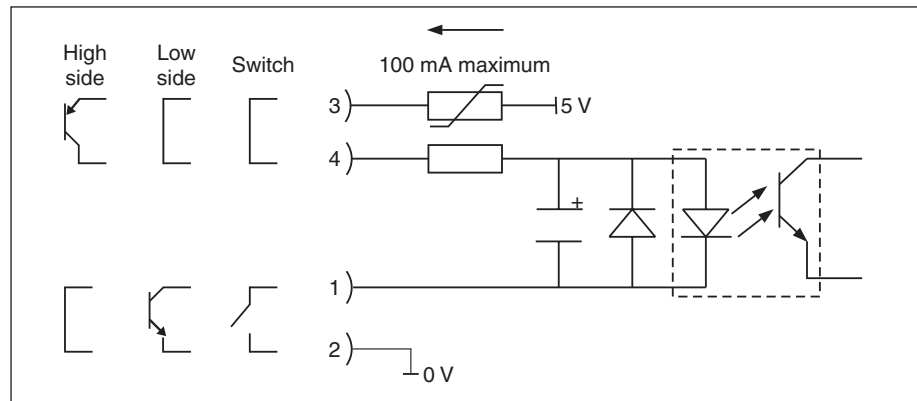

Figure 51 Reference mark switch (switch/solid state)

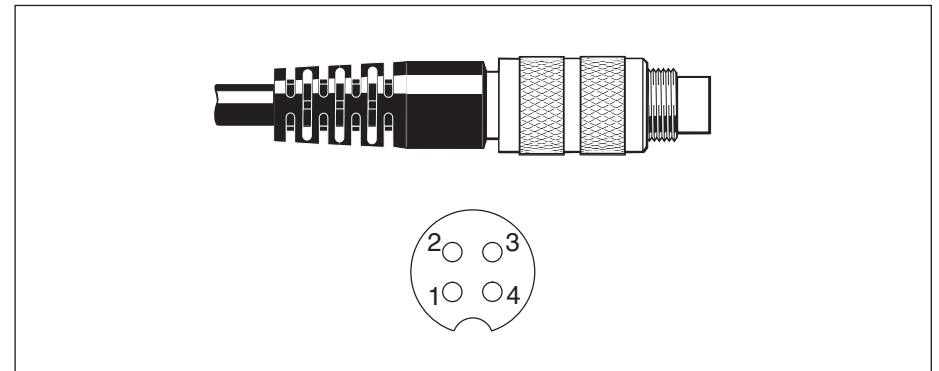

Figure 52 Reference mark AX1 and AX2 (4-way binder 712 male connector)

NOTE: This connector is viewed from the wiring side.

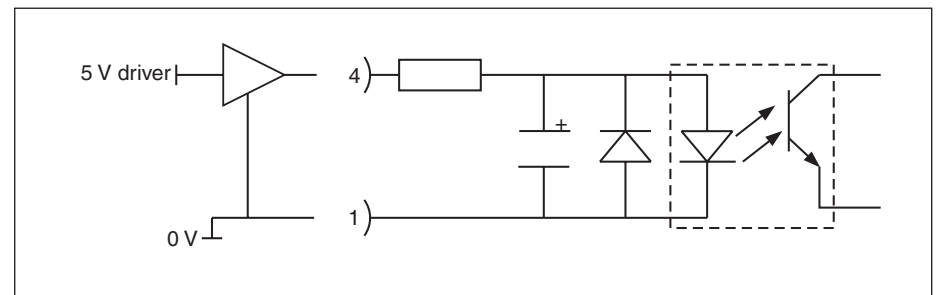

Figure 53 Reference mark switch (5 V)

Table 23 Reset (5-way binder 712 male)

Pin number	Function
1	Reset return
2	0 V supply ground
3	5 V supply
4	Reset input TTL
5	Reset input 24 V
Shell	Chassis ground

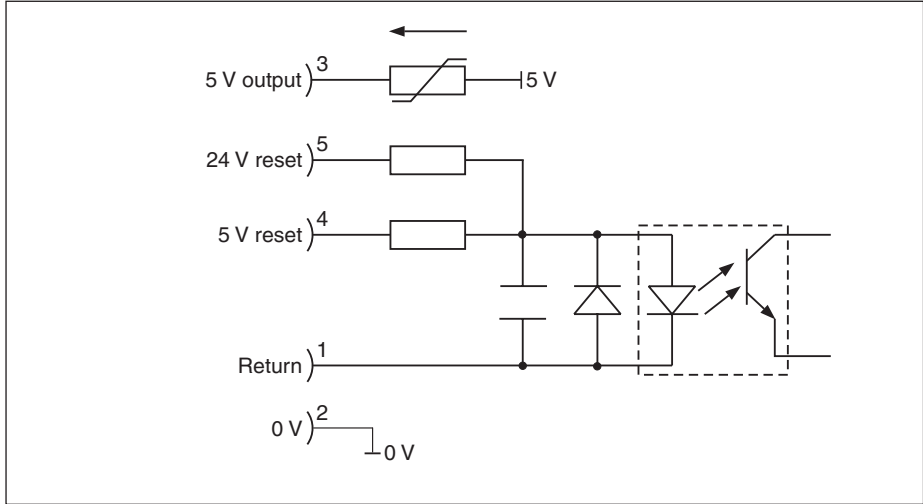

Figure 54 Reset input

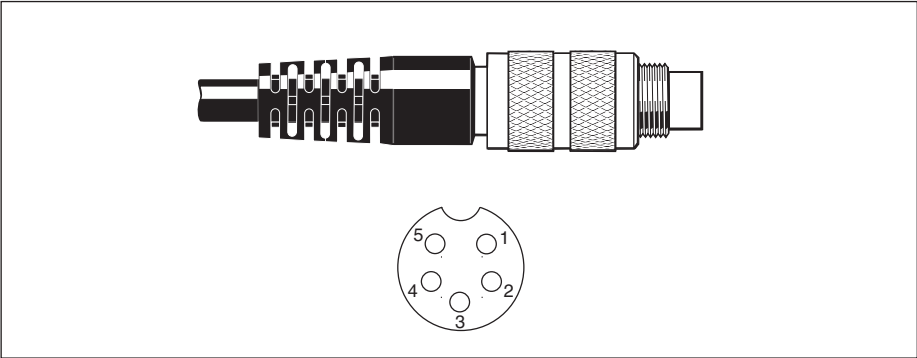

Figure 55 Reset (5-way binder 712 male connector)

NOTE: This connector is viewed from the wiring side.

Table 24 Shutter (5-way binder 712 male)

Pin number	Function
1	Return
2	0 V supply ground
3	5 V supply
4	Input TTL
5	Input 24 V
Shell	Chassis ground

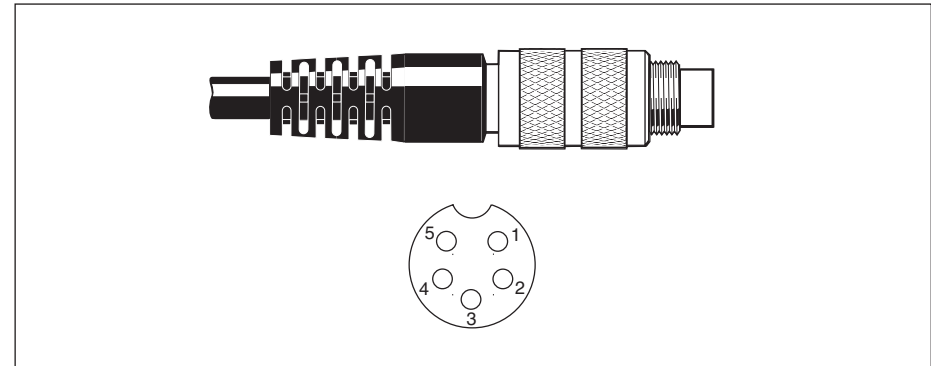

Figure 57 Shutter (5-way binder 712 male connector)

NOTE: This connector is viewed from the wiring side.

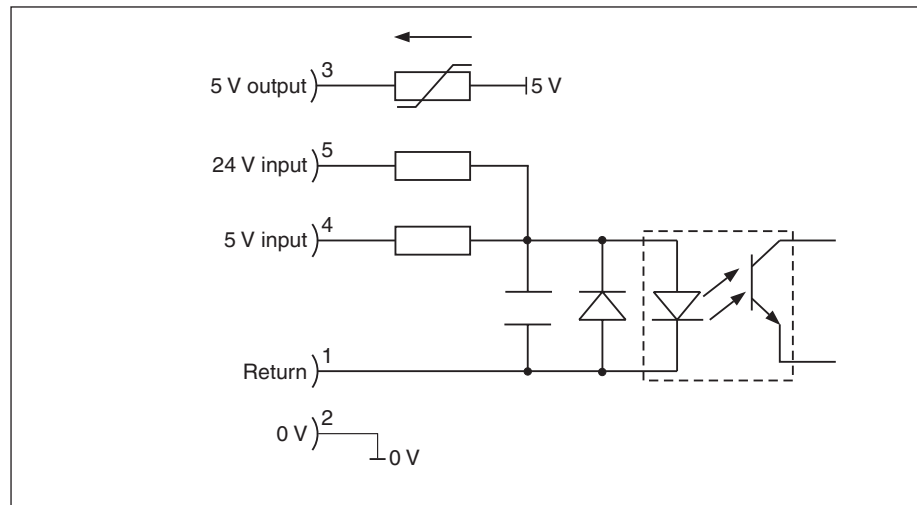

Figure 56 Shutter input

Table 25 Aux I/O (4-way binder 712 male)

Pin number	Function
1	AX1 signal strength (0 – 1 V)
2	0 V
3	0 V
4	AX2 signal strength (0 – 1 V)
Shell	Chassis ground

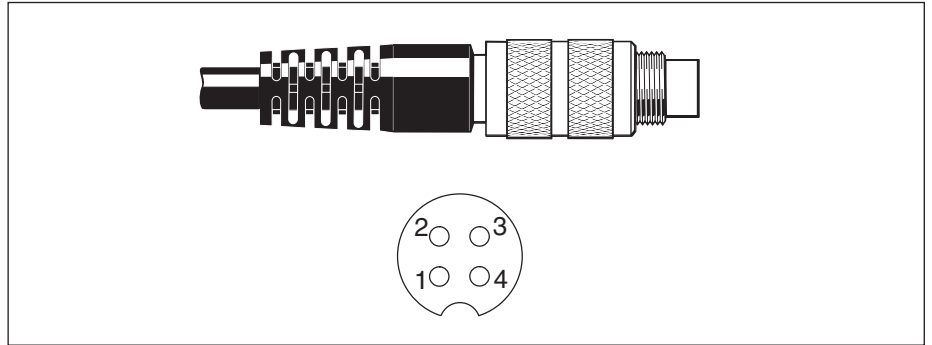

Figure 58 Aux I/O (4-way binder 712 male connector)

Table 26 Sensors AX1 and AX2 (4-way binder 712 male)

Pin number	Function
1	/Data
2	0 V
3	5 V
4	Data
Shell	Chassis ground

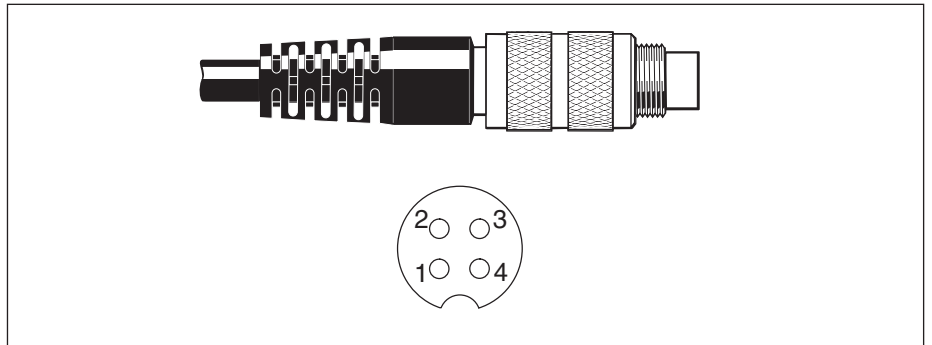

Figure 59 Sensors AX1 and AX2 (4-way binder 712 male connector)

NOTE: These connectors are viewed from the wiring side.

Appendix A - Interferometry

A.1 Interferometry guide

The fibre optic laser encoder is based on a technology called interferometry. It relies on a coherent source of light, produced by a laser, and a phenomenon called interference.

The laser's output beam can be imagined as a sinusoidal wave of light. The wavelength of the light in the Renishaw RLE system is 633 nanometres.

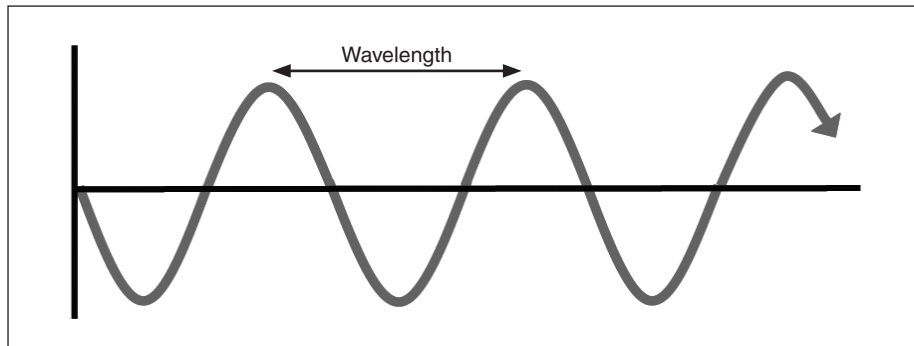

Figure 60 Sinusoidal light wave

Interference can be understood by considering summation of two such beams of light that have taken different paths. Figure 61 shows the beam paths in a typical linear interferometer system.

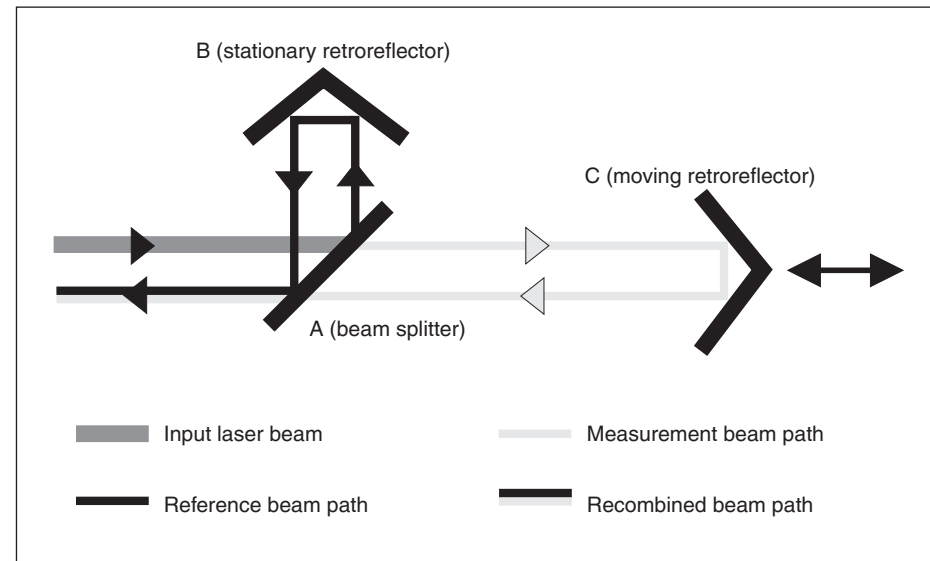

Figure 61 Linear interferometer beam paths

The light from the laser is split into two beams by a beam splitter (A). About half the laser light is sent to the stationary retroreflector (B) and forms the reference beam. The other half strikes the moving retroreflector (C) and forms the measurement arm.

The retroreflectors return the two beams back to the beam splitter where they recombine and interfere with each other.

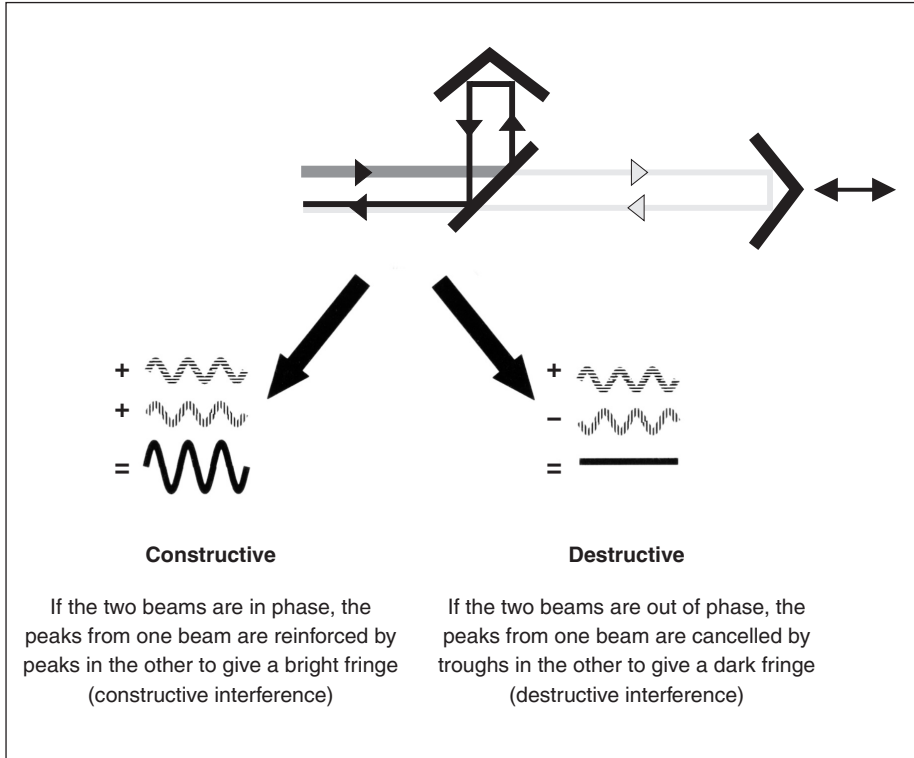

Figure 62 Constructive and destructive interference

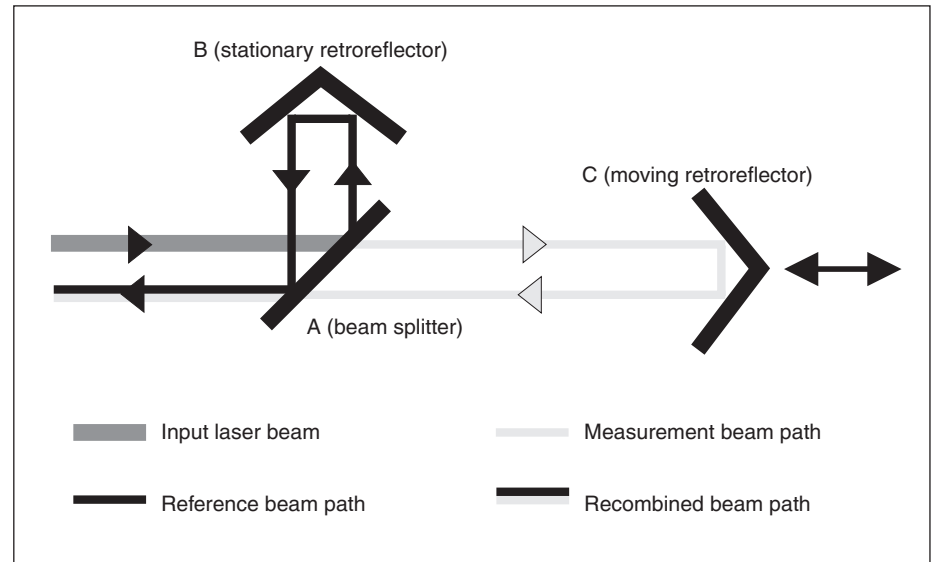

Figure 63 Detection of movement

As the length of the measurement beam path is changed (by moving the retroreflector), the relative phases of the beams will alter. The resulting cycle of constructive and destructive interference will cause sinusoidal variations in the intensity of the recombined beam. One cycle of intensity (bright to dark and back to bright) will occur if the retroreflector is moved by 316 nanometres (half the laser wavelength). Movement is detected by monitoring these changes in intensity.

A.2 Retroreflector interferometry

Figure 64 shows how the elements of the interferometry theory, shown on page 64, are incorporated in the RLD 90° (RRI).

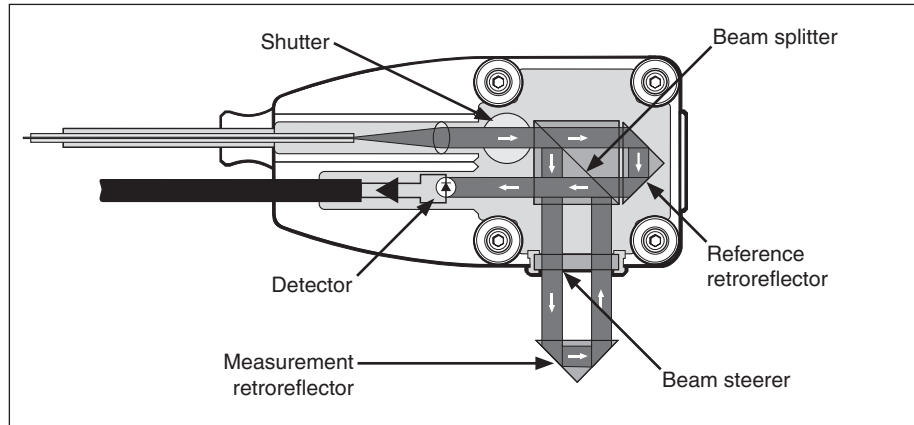

Figure 64 Operation of RLD 90° (RRI)

The RLD 0°, shown in Figure 65, shows the arrangement of optics with the reference retroreflector now positioned at 90° to the source beam and the measuring beam now passing straight through the beam splitter and beam steerer.

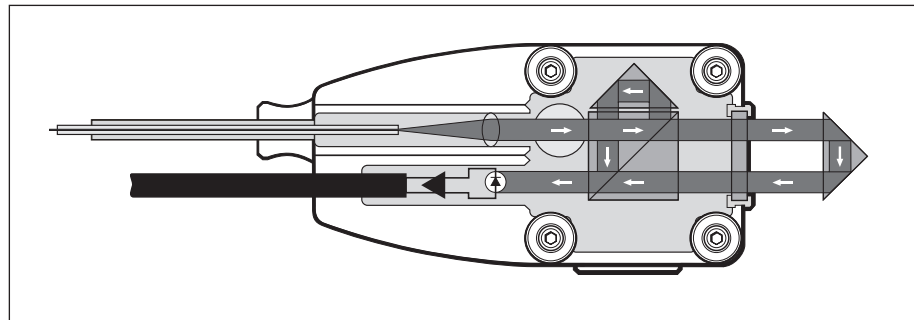

Figure 65 Operation of RLD 0° (RRI)

Interferometers are used to provide position feedback on a huge variety of machines ranging from machine tools to semiconductor inspection equipment. Figure 66 shows a typical retroreflector interferometer set-up in which a single axis system provides feedback for a linear motion stage.

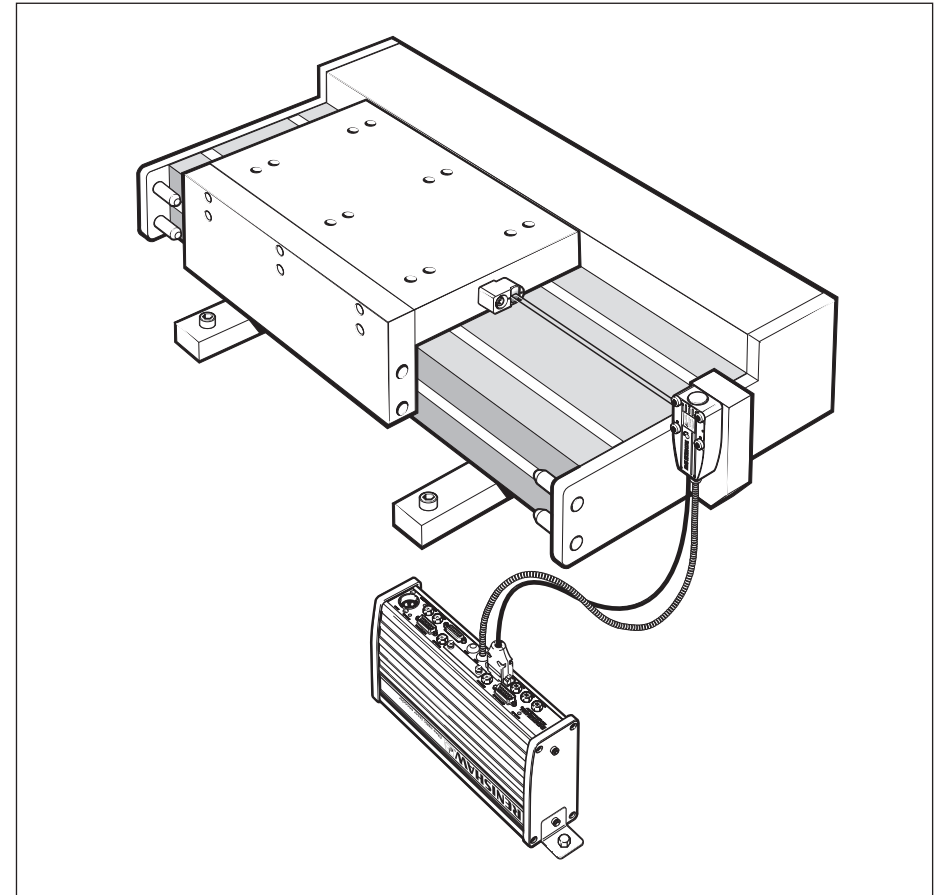

Figure 66 Typical retroreflector interferometer set-up

A.3 Plane mirror interferometry

Figure 67 shows how the elements of the interferometry theory are incorporated in the RLD 90° (PMI).

Although the PMI beam path looks more complicated than the RRI system, it is exactly the same except for the measurement beam path is doubled using a plane mirror. This doubles the resolution of the system and is well suited to X-Y stages, allowing Abbé offset errors to be minimised.

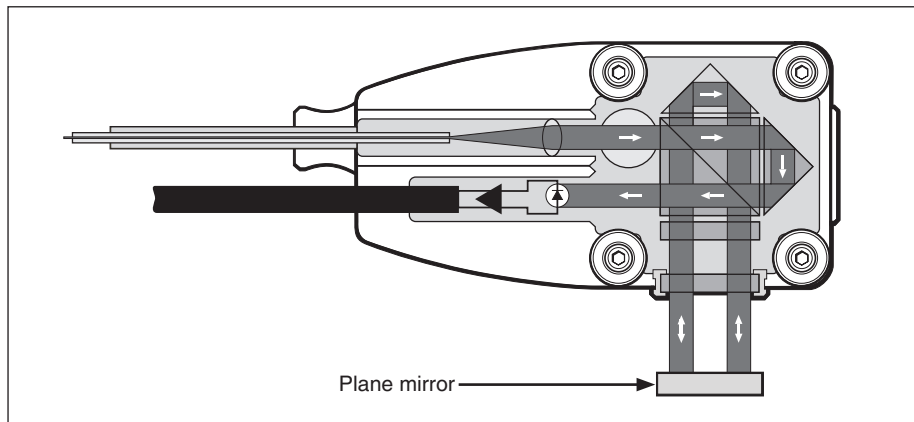

Figure 67 Operation of RLD 90° (PMI)

The RLD 0° (PMI) shown in Figure 68 shows an alternative arrangement of the system optics.

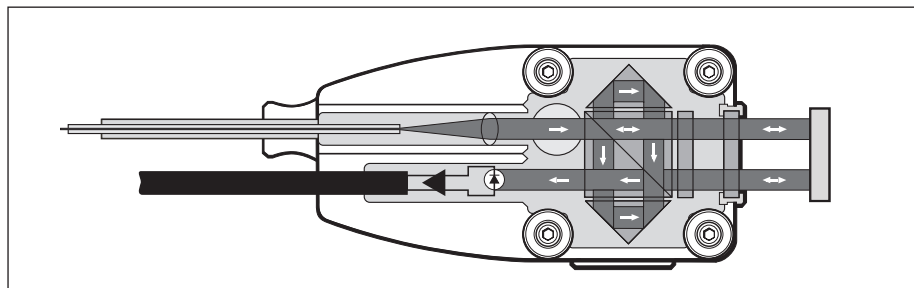

Figure 68 Operation of RLD 0° (PMI)

Interferometers are used to provide position feedback on a huge variety of machines ranging from machine tools to semiconductor inspection equipment. Figure 69 shows a typical plane mirror interferometer set-up in which a dual axis system is used to provide position feedback on an X-Y motion stage.

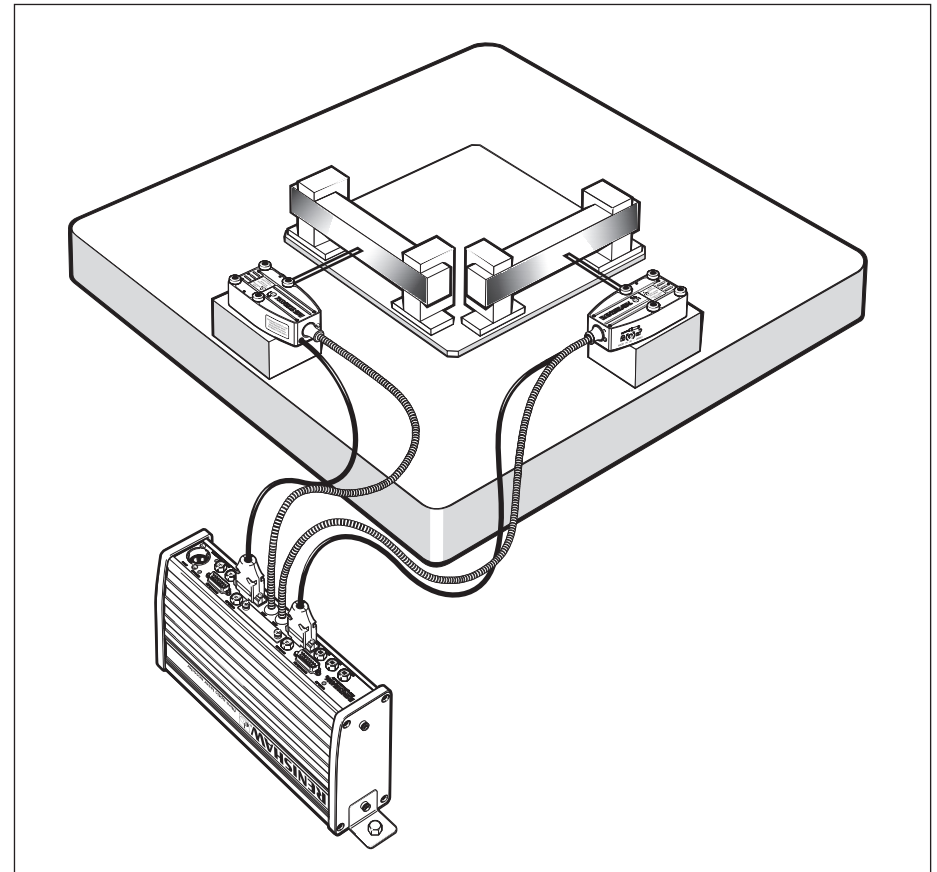

Figure 69 Typical plane mirror interferometer set-up

A.4 Differential interferometry

Figure 70 shows how the elements of the interferometry theory are incorporated in the RLD DI:

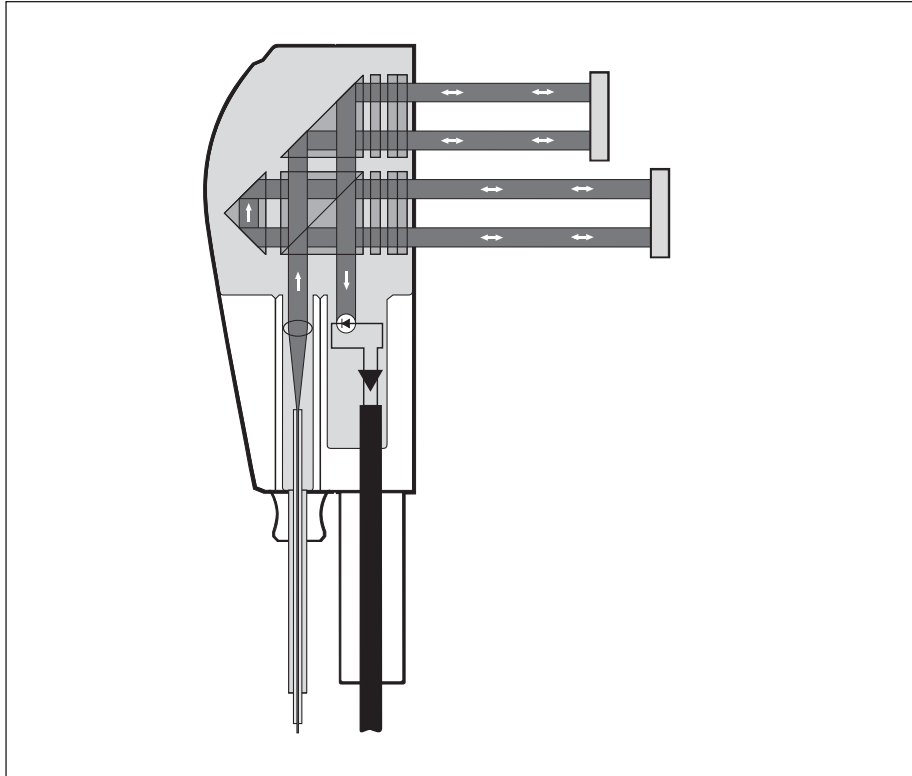

Figure 70 Operation of RLD DI

The advantage of the differential interferometer is that it allows the relative measurement of two external optics therefore eliminating common mode errors.

Appendix B - Maintenance

B.1 Adjustments and procedures

There are various adjustments and procedures that can be carried out by the user for operation, maintenance and service, including:

- Beam alignment using the laser beam steerer (see section 3.6)
- System parameter selection using the RLU configuration switches (see sections 3.3 and 3.4)
- Signal gain adjustment using the two potentiometers located on the side of the detector head (see Appendix B.4)

! **CAUTION:** Use of controls or adjustments or performance of procedures other than those specified may result in exposure to hazardous laser radiation in excess of Class II limits.

B.2 General maintenance

There are no user-serviceable parts inside the RLU or the RLDs. The only parts of the system that may require attention throughout their life are the exposed optics. If the system is not operated in a clean environment, surface contamination will accumulate on the optics over a period of time. This contamination will eventually affect the system performance by causing deterioration in the signal strength.

Optical cleaning

It is recommended that the optical surfaces be cleaned only when necessary. If the signal strength is low, first ensure that the beam alignment is optimised, as this may be the cause of the reduced signal strength.

There are only two surfaces that require cleaning on each axis of the system, the first being the external surface of the beam steerer situated in the detector head, the second being the external surface of the retroreflector or mirror.

The surfaces of the beam steerer and retroreflector can be cleaned using one of the following materials.

Do use

- Ethanol, methanol, propanol and combinations
- Spectacle cleaning fluid
- Non-abrasive, lint-free cleaning wipes
- Microfibre cloths

Do not use

- Acetone
- Abrasive materials
- Chlorinated solvents
- Benzine

Mirrors should only be cleaned with a soft, lint-free cloth.

Back reflection

It is possible to cause the laser to de-stabilise by back reflection of the measurement beam into the output aperture of the detector.

To understand if the laser is going unstable as a result of back reflection, manually block the laser beam so no light is being allowed to return to the detector. Allow up to 20 minutes for the RLU to stabilise.

If the RLU fails to stabilise in 20 minutes with no return beam, then contact Renishaw.

If the RLU stabilises when the beam is blocked, which can occur during alignment, but also because of contaminated optics or other reflections from the optical surfaces; either clean the optics or adjust the alignment slightly.

B.3 Troubleshooting

Table 27 Troubleshooting

Error	Check		Fix
The laser status LED is not illuminated (no power)	Is there power to the laser?	Yes	Cycle the power. We recommend allowing 10 minutes for the RLU to cool between cycles. If problem still occurs, consult your local Renishaw representative.
		Yes	Ensure the power requirements in Table 32 are met (see page 76).
		No	Turn the power on.
The laser status LED is red (laser failure)			Cycle the power. Consult your local Renishaw representative.
No laser beam is being emitted from the RLD	Is the RLD shutter closed (see Figure 23 on page 38)?	Yes	Open the shutter.
	Is the barrel located into both RLDs correctly?	No	Locate the barrel correctly
	Is there power to the laser?	No	Turn the power on.
	Is the laser beam shutter closed?	Yes	Activate the shutter.
No		Consult your local Renishaw representative.	
The laser status LED is amber (laser unstable)	Have you waited for the warm-up cycle to finish (up to 20 minutes)?	No	Wait for the warm-up cycle to finish.
		Yes	Consult your local Renishaw representative.
	Could there be a back reflection?	Yes	See 'Back reflection' on page 69.
The AX status LED is red (beam blocked)	Are the optics correctly aligned?	No	Re-align the optics.
	Are the optics contaminated?	Yes	Remove the contamination.
	Is the laser beam path obstructed?	Yes	Remove the obstruction.
The AX status LED is amber (beam low)	Are the optics correctly aligned?	No	Re-align the optics.
	Are the optics contaminated?	Yes	Remove the contamination.
The AX status LED is flashing red (overspeed)	Has the maximum velocity been exceeded?	Yes	Reduce the velocity or increase the clockrate.
	Are the signal cables near to the power cables?	Yes	Re-route the signal cables away from the power cables. Improve shields/grounds for the signal cabling.
	Is the RLD securely mounted?	No	Ensure the RLD is securely clamped down.
	Is the remote optic loose?	Yes	Ensure the remote optics are securely clamped down.

B.4 Matching RLD to RLU

Replacing an RLD

Each RLU laser unit is matched to one or two RLD detector heads to make a complete RLE fibre optic laser encoder system. A label showing RLD serial numbers, NTP wavelengths and RLU power information is affixed to the rear of the RLU laser unit. In the unlikely event of a RLD detector head malfunctioning, the replacement RLD will be shipped with a label indicating the RLD's serial number. The serial number of the defective RLD displayed on the rear of the RLU should be replaced with the new serial number label.

If a new RLD head is fitted to an RLU laser unit, its signal gain must be adjusted.

If the signal gain is not adjusted, errors may be asserted.

- A beam low error will be produced if the signal strength is below the acceptable threshold – the status LED will appear continuously amber.
- A beam saturation error will be triggered if the beam exceeds 120% signal strength – the status LED will appear continuously amber.



WARNING: Adjustment of the detector unit gain (located behind the laser information label) is a skilled task. Incorrect setting of these potentiometers can stop the position feedback and beam obstruct detection system from working correctly. This may result in generation of invalid position feedback signals without the usual error signal output, and may cause open loop motion of the axis. Ensure you are fully familiar with the setting procedure, and have the appropriate test equipment to verify the signal outputs before attempting to make adjustments.

Method of adjustment

1. Ensure that the RLU is not powered. Plug the new detector head into the front of the laser unit and insert the fibre barrel. Power up the laser and wait for the unit to stabilise.
2. Before proceeding, wait for the laser to have been powered for 40 minutes to allow it to fully settle.
3. Align the detector head to the axis of movement and maximise the signal ¹. It is important that the alignment is near perfect before proceeding.
4. Position configuration switch 5 down to produce an analogue output (ensure that the parity switch is set correctly) and attach a two-channel oscilloscope to pin 5 and 6 with a common ground of pin 1 to the 15-way D-type controller plug on the front of the RLU laser unit.
5. Ensure you connect to the axis which the new RLD is connected to.
6. Switch the oscilloscope into X vs. Y mode (this procedure will be particular to the model of oscilloscope used). The oscilloscope should be set to 500 mV/div on both channels.
7. Monitor the Lissajous produced by axis movement – it should have a 1 V diameter and be circular.

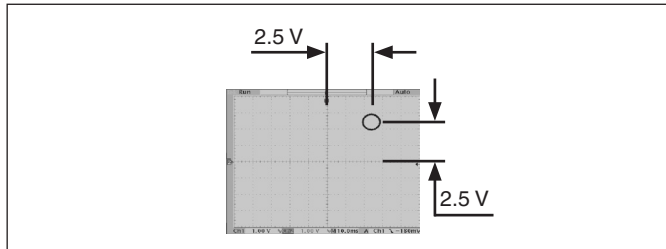

Figure 71 Lissajous

¹ These adjustments should preferably be carried out on a test fixture where it is easier to achieve perfect alignment.

8. If you do not have 1 V signal strength, it can be adjusted using the two potentiometers located on the side of the detector head. The gain adjusters are the two holes A and B shown in Figures 72 and 73. Take care when adjusting the potentiometer, as they are delicate electronic components.

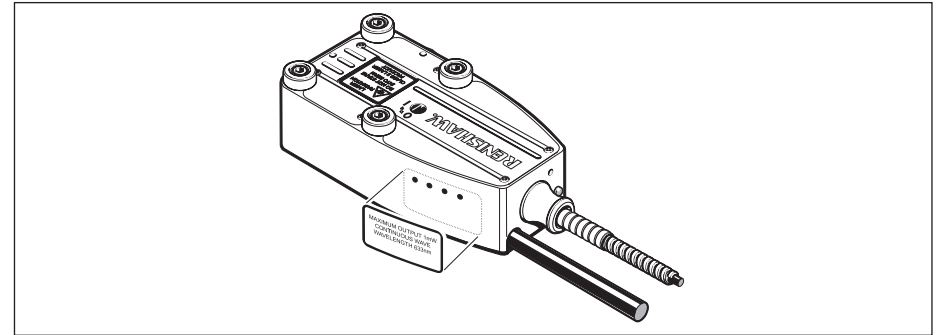

Figure 72 Position of potentiometers on RLD head

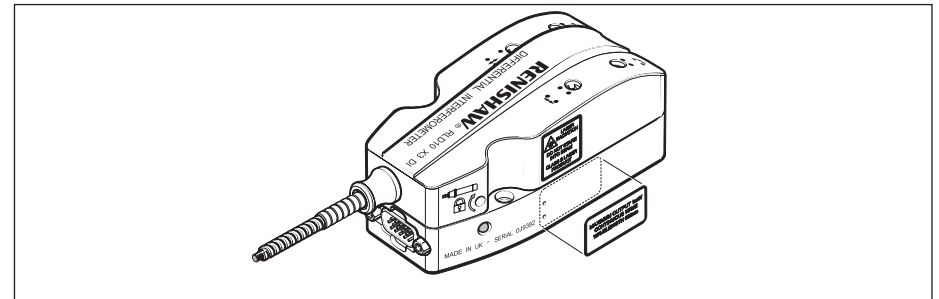

Figure 73 Position of potentiometers on RLD DI head

Table 28 Potentiometers

Potentiometer	Function	Measure
A	Cosine gain	Pin 6
B	Sine gain	Pin 5
C	Do not adjust	-
D	Do not adjust	-

Appendix C - Measurement errors

C.1 Overview

Interferometer measurement errors can be categorised as intrinsic, environmental or geometric. The following section gives a brief overview of these errors.

Intrinsic errors

Please refer to Table 29 for intrinsic error magnitudes.

- SDE (or non-linearity)** This is a non-accumulative error generally caused by non-roundness of the Lissajous. It is made up of significant contributions from the laser system and the interface. The total non-linearity error is the sum of the two.
- Frequency stability** This error occurs when the frequency of the laser output varies.
 Error = frequency variation × measurement distance
- Dynamic** This positional offset error is produced in dynamic applications if an encoder has any signal latency (data age). However, if the nominal data age value is known, compensation can be applied to eliminate the offset.

 Any variation in data age cannot be compensated for and will therefore result in a positional uncertainty.
 Positional offset = data age × velocity
 Positional uncertainty = data age variation × velocity
- Electrical noise** The RLE system measures phase by comparing the intensities of two sinusoidal signals. Any noise on the feedback signals directly translates to positional error.

Environmental errors

- Thermal drift coefficient** This error is the change of the interferometer's reference position with temperature.
- Refractive index** The wavelength of a laser beam will vary slightly depending on the refractive index of the air it travels through.
 (0.96 ppm/°C, -0.27 ppm/mbar, 0.0085 ppm/%RH)

 The refractive index of the air depends primarily on its temperature, pressure and humidity.

Geometric errors

- Cosine error** This error occurs if the axis of measurement (interferometer axis) is not parallel to the axis of motion. It can be calculated using simple trigonometry:
 Cosine error = $L (1 - \cos \theta)$
 where L is the axis length and θ the angular error.
 For more information on cosine error, see section [C.2](#).
- Abbé error** Abbé error occurs when the encoder axis is offset from the working axis. If the stage pitches or yaws, the movement of the workpiece is different from the encoder reading.

 For an offset of d and a stage pitch of θ , the resulting Abbé offset error will be:
 Abbé error = $d \times \sin \theta$
- X-Y errors** If a plane mirror is misaligned to the parallel axis, a measurement error will be caused.

 When a beam traverses a length L of a mirror, which is misaligned by an angular deviation Φ , from the parallel axis:
 Measurement error = $L \sin \Phi$

C.2 Cosine error

Cosine error is introduced by not measuring in line with the axis motion. This error can be calculated using simple trigonometry.

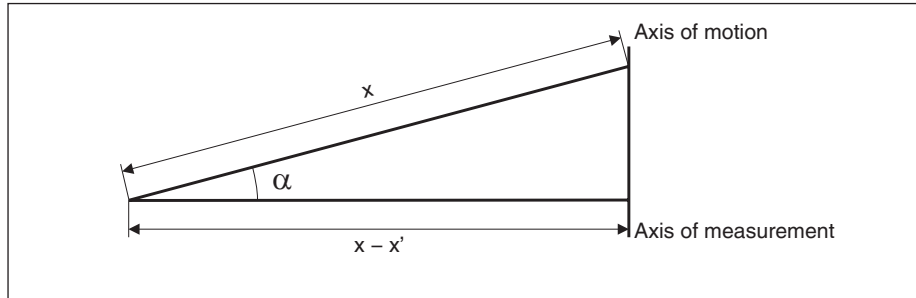

Figure 74 Cosine error

Cosine error = axis length (1 – cosine α)

Example

If the angular error (α) is 50 arcseconds on a 1000 mm axis, the system will measure short by 29.4 nanometres. The graph (Figure 75) shows how the error varies with angle and axis length.

$$\cosine \alpha = \frac{1000 - x'}{1000}$$

$$x' = 1000 (1 - \cosine \alpha)$$

$$x' = 29.4 \text{ nm}$$

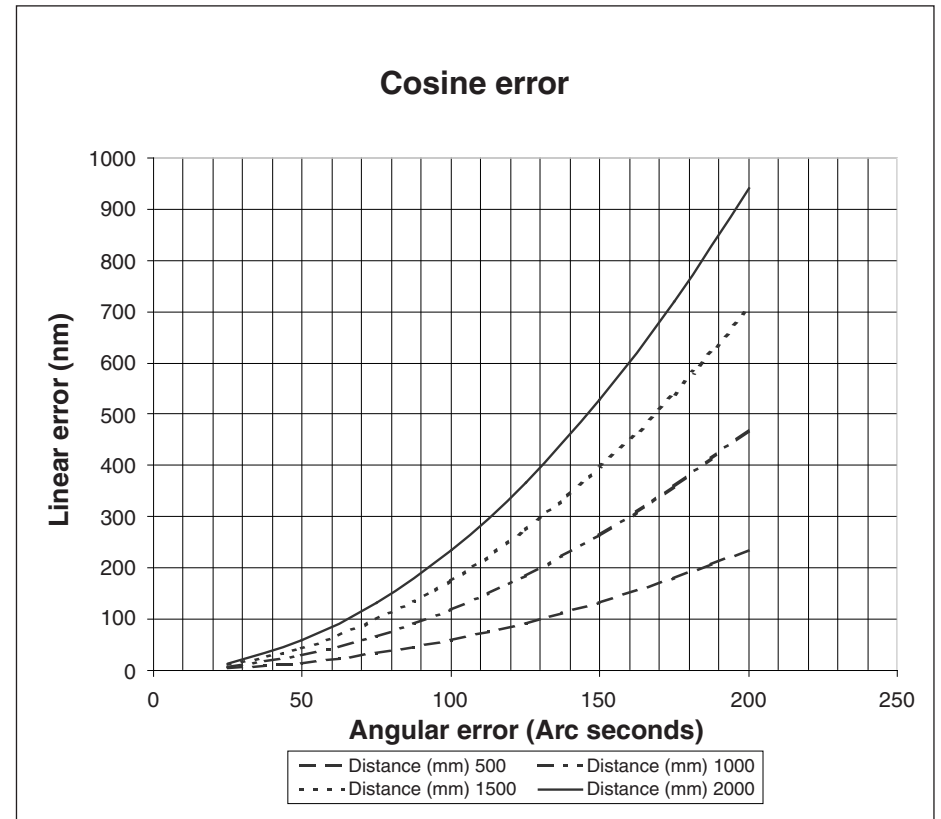

Figure 75 Cosine error

Appendix D - Specifications

D.1 System specifications

Table 29 System specification

Axis travel	PMI		0 m to 1 m
	RRI		0 m to 4 m
	DI	Measurement arm	0 m to 1 m
		Reference arm nominally fixed	0 m to 0.5 m
Maximum velocity ¹	PMI and DI		< 1 m/s
	RRI		< 2 m/s
System nonlinearity error (SDE) ²	< 5% of maximum velocity with > 70% signal strength	PMI	< ±2.5 nm
		RRI	< ±5 nm
		DI	< ±1 nm
	At maximum velocity with > 50% signal strength	PMI	< ±7.5 nm
		RRI	< ±13 nm
		DI	< ±6 nm
Vacuum wavelength accuracy	±0.1 ppm		(3 years)
Vacuum wavelength stability	RLU10	RLU20 ³	
	±10 ppb	±1 ppb	1 minute
	±0.05 ppm	±2 ppb	1 hour
	±0.05 ppm	±20 ppb	8 hours

¹ When using digital quadrature, additional bandwidth limitations apply – refer to 'Table 1 Maximum system velocities' on page 14 for details.

² Excluding interface.

³ The RLU20 must be switched on for two hours before it meets the vacuum wavelength stability specification.

Table 29 System specification (continued)

Thermal drift coefficient	PMI and RRI	< 100 nm/° C	Measured by mounting measurement optic and detector close together on an Invar (or low thermal expansion) base and changing the temperature
	DI	< 50 nm/ ° C	Measured using a common measurement and reference mirror and changing the temperature
Electrical noise (up to 10 MHz analogue bw)	PMI and DI		< 0.1 nm
	RRI		< 0.2 nm
Data age – digital quadrature	Nominal PMI		625 ns
	Variation in nominal from axis to axis		±15 ns
	Jitter		See Table 36 on page 77
Data age – analogue quadrature	Nominal		120 ns
	Variation in nominal from axis to axis		±15 ns
	Short term variation (constant environmental conditions)		< ±2 ns

Table 30 RLD specification

Beam diameter	3 mm		Divergence < 0.25 mrad
Beam separation	PMI/RRRI	7 mm	Centre to centre
	DI	7 mm x 14 mm	Centre to centre
Beam alignment adjustment	PMI/RRRI	±0.65° pitch	Integrated beam steering to simplify beam alignment
		±1.5° yaw	
	DI	±1° pitch	Independent adjustment of measurement and reference beams
		±1° yaw	
Mirror alignment tolerance (PMI/DI)	±25 arcseconds @ 1 m		Tolerance applies to both pitch and yaw during operation
Retroreflector alignment tolerance	±0.25 mm		
Cable length (standard)	3 m		
Cable diameter	6.5 mm		
RLD cable and RLU fibre bend radii	25 mm	Static	
	50 mm	Dynamic	
RLD component weight (PMI/RRRI)	200 g	Alone	
	400 g	With cable	
RLD component weight (DI)	400 g	Alone	
	690 g	With cable	
Heat dissipation	< 2 W		
Max laser power from RLD apertures	< 200 µW (CW)		During preheat this can rise up to 400 µW

Table 31 RLU specification

Weight	2.8 kg	
Heat dissipation	< 15 W (after warm-up)	
Fibre conduit diameter	5 mm	Removable from the detector head (connector 12 mm diameter)
Max. operating laser power from fibre barrel	< 300 µW (CW)	During preheat this can rise up to 600 µW

Table 32 RLU power requirement

Status	Voltage	Current	Power
Inrush (first 10 ms)	+24 V DC	2.5 A	-
Warm-up (up to 20 minutes)	+24 V DC	1.6 A Peak	40 W
Operation at room temperature (20 °C)	+24 V DC	0.6 A	< 15 W

The 24 V power supply should be single fault tolerant certified to EN (IEC) 60950-1.



WARNING: The correct power supply voltage is 24 V ±2 V. Power supplies outside this range may give unreliable operation.

Table 33 Operating environment

Pressure	Normal atmospheric (650-1150 mbar)	
Humidity	0-95% RH (non-condensing)	
Temperature	Storage	-20 °C to 70 °C
	Operating ¹	10 °C to 40 °C

Table 34 NTP wavelength

T = 20 °C, P = 1013.25 mbar, RH = 50%	
Axis 1	632.818270
Axis 2	632.819719
Wavelength accuracy	±0.1 ppm over 3 years

NOTE: Resolutions are directly derived from the wavelength.

Table 35 Vacuum wavelength

AX1 (nm)	AX2 (nm)
632.990000	632.991450

Table 36 Jitter

Digital bandwidth (MHz)	Jitter (±ns)
0.3125	1600
0.625	800
1.25	400
2.5	200
5	100
10	50
20	25

¹ RLD DI SDE specification of ±1 nm only achieved over temperature range of 15 °C to 30 °C.

Low power RLD specification

The low power RLD range has been designed for applications requiring an RLD heat dissipation lower than the specified < 2 W. All deviations from the standard RLD are detailed in table 37 – all other parameters can be assumed to be identical to their standard counterparts.

Table 37 Specification deviation

Heat dissipation	0.14 W	
Nominal data age ¹	2.9 μ s	
Analogue bandwidth	150 KHz	
Maximum speed ²	RRI	47.4 mm/s
	PMI	23.7 mm/s

RLD power indication

The power LED, detailed on page 46, has been removed to minimise heat dissipation – the location has been blackened to avoid confusion.

Identification

Low power units can be identified by the engraving on the plug located on the front or side of the unit. An “L” in the second half of the part number indicates that the RLD is a low power version.

Part numbering

Low power plane mirror RLD (3 m cable):

RLD10-A3LP0
RLD10-A3LP9

Low power retroreflector RLD (3 m cable):

RLD10-A3LR0
RLD10-A3LR9

Low power plane mirror RLD (6 m cable):

RLD10-B3LP0
RLD10-B3LP9

Low power retroreflector RLD (6 m cable):

RLD10-B3LR0
RLD10-B3LR9

¹ This has an estimated axis-to-axis variation of $\pm 3\%$.

² This applies to all available resolutions.

Appendix E - Safety information

E.1 Laser beam description and safety labels

1 mW continuous wave output, collimated with a gaussian intensity distribution and a full beam diameter of 3 mm.

The following safety labels are attached to the RLE fibre optic laser encoder:

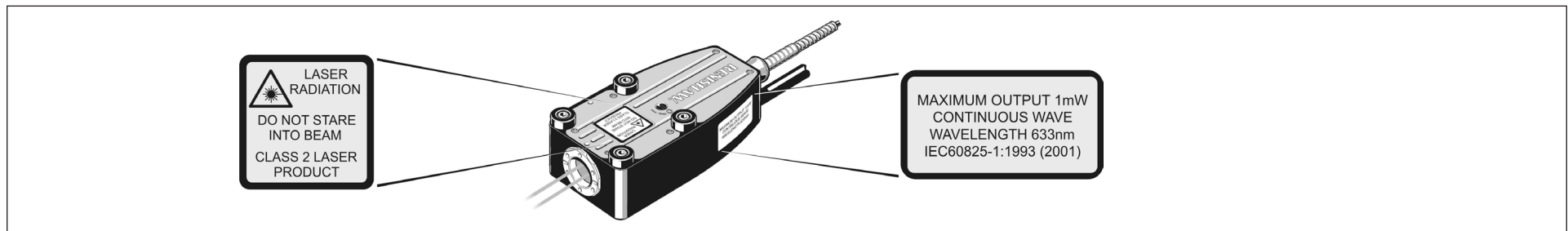

Figure 76 RLD PMI and RRI detector head safety labels

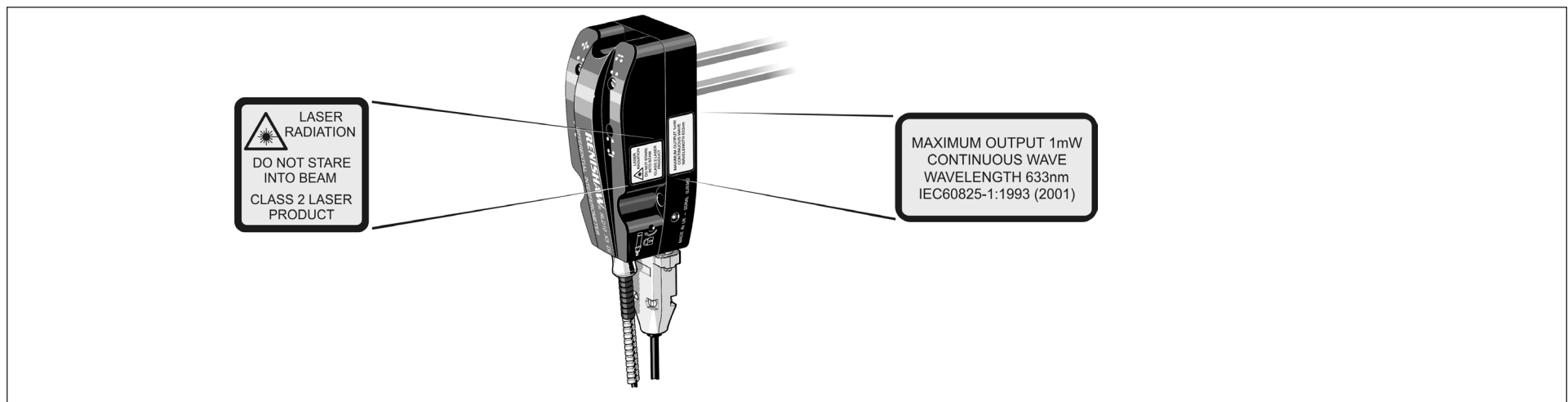

Figure 77 RLD DI detector head safety labels

NOTE: It is advisable to ensure that these labels are attached and visible when the RLE system is installed.

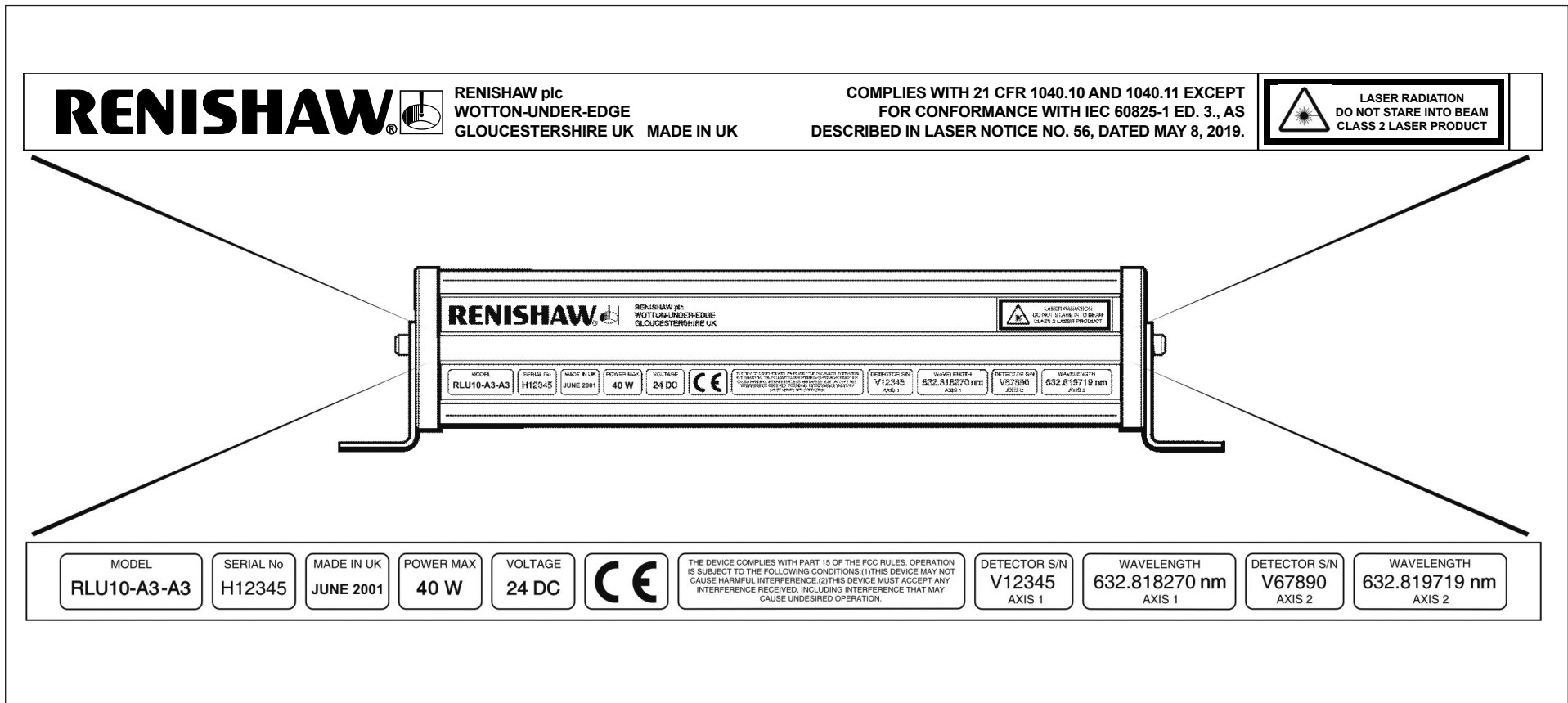

Figure 78 RLU laser unit safety labels

E.2 Motion system safety

General

The Renishaw laser encoder and compensator (manual number M-9904-1122) systems are designed for integration into the primary position feedback loop of a motion system. It is essential that the system is installed in accordance with the instructions in the installation manuals and it is the responsibility of the system integrator to ensure that, in the event of a failure of any part of the Renishaw laser system, the motion system remains safe.

In motion systems with powers or speeds capable of causing injury, safety protection measures must be included in the design. It is recommended that satisfactory operation of these protection measures is verified before the feedback loop is closed. The following are examples of safety protection measures that can be used. It is the sole responsibility of the system integrator to select appropriate measures for their application.

1. The Renishaw system includes an error signal output. The control system must be designed to stop the axis motion if this error output is asserted. In addition to the error signal, the position feedback signals can also be configured to go tristate (open circuit) under fault conditions. Some controllers can be programmed to detect this, thereby providing a further level of protection in case of failure of the error signal output (see item 3). If the controller is not capable of detecting open circuit position feedback signals, this option must not be enabled.
2. The axis must include physical limit switches which, when tripped, will stop axis motion before damage occurs (soft limits alone are insufficient). Note that in the case of thermally compensated systems, positional corrections of several hundred ppm are possible. This should be taken into account when defining the relative positions of soft and hard axis limits.
3. Cable breakage detection (encoder disconnect). The position feedback and error signal lines are all provided as differential line driven pairs. Failure in the cable or of the line drivers can be detected by checking these differential pairs are always being driven in opposing states. If the lines are not in opposing states, the motion must be stopped.
4. Motor torque monitoring. If the motor torque exceeds an expected limit, the axis of motion must be stopped.
5. The machine must include an emergency stop button.
6. Following error detection. If the difference between the controller demand position and the axis feedback position exceeds an expected limit, the axis motion must be stopped.

7. Guards, viewing windows, covers and interlocks may be used to prevent user access to hazardous areas, and to contain ejected parts or materials.
8. If the machine includes an independent tacho (velocity) feedback system, this should be cross-checked with the position feedback. For example, if the tacho indicates the axis is moving, but the position feedback doesn't, the axis motion must be stopped.
9. In the case of synchronised parallel motion systems (for example twin rail gantry drive systems), the relative positions of master and slave axes should be monitored. If the difference in their positions exceeds an expected limit, axis motion must be stopped.

NOTE: In the case of measures 6 to 9, the limits need to be selected carefully depending on the application and the type of position compensation selected to avoid false alarms.

For further advice, consult the appropriate machinery safety standards.

Quadrature resolution warning

It is important to set the output resolution of the Renishaw system to match the controller's input resolution. If the quadrature resolution is set incorrectly, the axis may move for distances and at speeds that are not expected. For example, if the output resolution from the Renishaw system is set to half that of the controller input, the axis may move twice as far and twice as fast as expected.

Direction sense warning

It is important to set the direction sense correctly. If it is set incorrectly, the machine will move in the opposite direction to that expected, and may accelerate until it reaches the axis limits. In the case of parallel twin rail drives, it is important that the direction sense of the slave axis is set to match the master axis. Failure to do this will cause opposite ends of the cross-member to move in opposite directions, possibly causing damage to the machine.

Error signal monitoring

The RLE fibre optic laser encoder continuously checks for internal errors that may cause invalid position feedback signals, and signals a fault by asserting an error line output. In the case of closed loop motion systems, for safe operation the status of this error line must be monitored. If the error line is asserted, the position feedback signals may be incorrect and the axis of motion must be stopped.

NOTE: In the event of power loss from the RLE, error lines become inactive and the axis of motion must be stopped.

Detector unit potentiometer adjustment

Adjustment of the detector unit gain potentiometers (located behind the laser information label) is a skilled task. Incorrect setting of these potentiometers can stop the position feedback and beam obstruct detection system from working correctly. This may result in generation of invalid position feedback signals without the usual error signal output, and may cause open loop motion of the axis. Ensure you are fully familiar with the setting procedure, and have the appropriate test equipment to verify the signal outputs before attempting to make adjustments.

Incorrect bandwidth setting

The laser system allows you to adjust the maximum update rate of the digital encoder output signals. If this is set too low (for the axis feedrate and resolution required) the laser system will flag when overspeed error occurs. If the update rate is set too high, your controller may not be able to count quickly enough to record all of the incoming pulses, and the axis may travel further than expected. It is important that the output bandwidth of the laser system is set below the maximum input bandwidth of the controller.

Laser alignment

If the laser beam is misaligned during beam alignment, the error line will be asserted due to low signal strength. Also, if the laser beam is misaligned such that the return beam enters the laser output port, it is possible that the laser will be destabilised. This is normal behaviour, and again the error line may be asserted. In either circumstance, the laser position feedback signals may be invalid. For this reason, initial beam alignment is usually performed with the machine under manual or open loop control.

Power supply out of range

The correct power supply voltage is 24 V \pm 2 V. Power supplies outside this range may give unreliable operation.

Sensor input port

Do not connect anything other than Renishaw RCU sensors to the sensor port.

Appendix F - Glossary

- Bandwidth** The maximum count frequency which may be applied to the controller/counter input. In a quadrature signal, count rate is 4 x signal frequency.
- Beam splitter** An optic which is used to split the two polarisation states of the laser beam into measurement and reference arms.
- Compensation** The process of applying a defined formula (Edlen) to the environmental conditions in order to correct errors on the laser wavelength to improve accuracy.
- Count rate** The rate at which count increments are produced by movement.
- $$\text{count rate} = \frac{\text{feedrate}}{\text{quadrature resolution}}$$
- This must be below the update rate, otherwise an overspeed error will occur.
- DI** Differential interferometry. Method using two dual pass beams to measure the relative position of two plane mirror surfaces.
- Fringes** Optical signals produced by the combination of the reference and measurement beams in the interferometer.
- Fundamental wavelength** The wavelength of the heliumneon laser tube which can be expressed at vacuum or defined conditions such as NTP.
- Hysteresis** A method of reducing noise or oscillation in measurement signals by using a positional delay of 1 count.
- Measurement beam (arm)** The part of the split laser beam which passes to the moving optic being measured.
- NTP** Normal temperature and pressure (20 °C, 1013.25 mbar, 50% RH).
- PMI** Plane mirror interferometry. Measurement method using a dual pass beam onto a plane mirror surface.

- Reference beam (arm)** The part of the split laser beam which passes through the fixed reference path in the detector head.¹
- Resolution** The distance separation of the encoder output signal, this being the smallest increment possible.
- RRI** Retroreflector interferometry. Measurement method using a single pass beam into a retroreflector optic.
- RS422/485** An electronic line transmission standard using noise immune differential signals.
- Stabilised laser** A laser tube which is actively controlled to achieve a constant laser frequency.
- Switch parity** A method of detecting errors by checking that the number of switches in the enabled position is even.
- Tristate** An open circuit state condition which may be applied to the laser output signal lines to indicate an error.
- Update rate** The rate at which the digital output quadrature is updated. The minimum edge-edge time may be calculated by:

$$t = \frac{1}{\text{update rate}}$$

¹ In a PMI or RRI RLD this beam remains inside the RLD. In an RLD DI this beam is aligned to the customer's external reference mirror.

Index of figures and tables

	Page number
24 V power supply input (Figure 50)	58
24 V power supply input (Table 21)	58
Air turbulence gasket (Figure 48)	56
Alignment aid (Figure 45)	54
Alignment aid for DI variant (Figure 39)	51
Alignment aid viewed towards chamber (Figure 47)	55
Alignment target stickers (Figure 37)	50
Analogue differential line driver outputs (Figure 6)	13
Aux I/O (Figure 58)	62
Aux I/O (Table 25)	62
Belden cable range (Table 13)	32
Cable termination (analogue signals) (Figure 15)	32
Cable termination (digital signals) (Figure 14)	31
Cable terminations (Table 11)	31
Constructive and destructive interference (Figure 62)	64
Cosine error (Figure 74)	74
Cosine error (Figure 75)	74
Default setting of configuration switches (Figure 25)	40
Detection of movement (Figure 63)	64
Dimensions of RLD 0° detector head (Figure 10)	26
Dimensions of RLD 90° detector head (Figure 9)	25
Dimensions of RLD DI detector head (Figure 12)	28
Dimensions of RLU laser unit (horizontal mounting) (Figure 7)	23
Dimensions of RLU laser unit (vertical mounting) (Figure 8)	24
Effects of air changes on wavelength (Table 5)	15
Error output signal (Table 14)	34
Far field adjustment (Figure 42 and 42a)	52
Fibre connection – RLD DI (Figure 22)	36
Fibre connection – RLD PMI, RRI and XX (Figure 21)	36



	Page number
Front panel (Figure 29)	45
Hysteresis (Figure 26)	42
Jitter (Table 36)	77
LED status (Table 18)	46
Linear interferometer beam paths (Figure 61)	63
Lissajous (Figure 71)	72
Low power RLD specification (Table 37)	78
Maximum system velocities (Table 1)	14
Metal target (Figure 38)	50
Mounting options (Figure 28)	44
Near field adjustment (Figure 41)	52
NTP wavelength (Table 34)	77
Number of twisted pairs per function (Table 10)	30
Operating environment (Table 33)	77
Operating the shutter (Figure 23)	38
Operation of RLD 0° (Figure 68)	66
Operation of RLD 0° (RRI) (Figure 65)	65
Operation of RLD 90° (PMI) (Figure 67)	66
Operation of RLD 90° (RRI) (Figure 64)	65
Operation of RLD DI (Figure 70)	67
Output format (Table 15)	41
Part numbers for RLE10 dual axis systems (Table 7)	19
Part numbers for RLE10 single axis systems (Table 6)	18
Part numbers for RLE20 dual axis systems (Table 9)	21
Part numbers for RLE20 single axis systems (Table 8)	20
Pitch adjustment (Figure 33)	47
Pitch and yaw controls (Figure 46)	55
Position of alignment grooves (Figure 40)	51
Position of alignment grooves (Figure 43)	53

	Page number
Position of potentiometers on RLD DI head (Figure 73)	72
Position of potentiometers on RLD head (Figure 72)	72
Potentiometers (Table 28)	72
Power LED on RLD DI variant (Figure 31)	46
Power LED on RLD PMI, RRI and XX variants (Figure 30)	46
Reference mark AX1 and AX2 (Figure 52)	59
Reference mark AX1 and AX2 (Table 22)	59
Reference mark operation (Figure 27)	43
Reference mark switch (5 V) (Figure 17)	33
Reference mark switch (5 V) (Figure 53)	59
Reference mark switch (switch/solid state) (Figure 16)	33
Reference mark switch (switch/solid state) (Figure 51)	59
Reference mark (Z) timing (Figure 18)	34
Reset (Figure 55)	60
Reset input (Figure 19)	35
Reset input (Figure 54)	60
Reset (Table 23)	60
RLD 0° and RLD XX detector head (Figure 2)	11
RLD 90° detector head (Figure 3)	11
RLD DI detector head (Figure 4)	12
RLD DI detector head safety labels (Figure 77)	79
RLD DI mounting arrangement (Figure 13)	29
RLD DI pitch and yaw adjustment (Figure 35)	48
RLD PMI and RRI detector head safety labels (Figure 76)	79
RLD retroreflector alignment dimensions (Figure 11)	27
RLD specification (Table 30)	76
RLE output resolutions – NTP (Table 4)	15
RLE output resolutions – vacuum (Table 3)	15
RLU configuration switches (Figure 24)	39
RLU laser unit (Figure 1)	10
RLU laser unit safety labels (Figure 78)	80

	Page number
RLU output direction (analogue) (Table 16)	41
RLU output direction (digital) (Table 17)	41
RLU power requirement (Table 32)	76
RLU specification (Table 31)	76
RS422 differential line driver outputs (Figure 5)	13
Sensors AX1 and AX2 (Figure 59)	62
Sensors AX1 and AX2 (Table 26)	62
Shutter (Figure 20)	35
Shutter (Figure 57)	61
Shutter input (Figure 56)	61
Shutter (Table 24)	61
Signal out AX1 and AX2 to controller (Figure 49)	57
Signal out AX1 and AX2 to controller (Table 20)	57
Signal strength meter (Figure 36)	49
Signal strength (Table 19)	49
Sinusoidal light wave (Figure 60)	63
Steering wedges (Figure 44)	54
System specification (Table 29)	75
Translation adjustment (Figure 32)	47
Troubleshooting (Table 27)	70
Typical plane mirror interferometer set-up (Figure 69)	66
Typical retroreflector interferometer set-up (Figure 66)	65
Update rate (Table 12)	31
Vacuum wavelength (Table 2)	15
Vacuum wavelength (Table 35)	77
Yaw adjustment (Figure 34)	47

www.renishaw.com/contact

 #renishaw

 +44 (0) 1453 524524  uk@renishaw.com

© 2004-2026 Renishaw plc. All rights reserved. This document may not be copied or reproduced in whole or in part, or transferred to any other media or language by any means, without the prior written permission of Renishaw.
RENISHAW® and the probe symbol are registered trade marks of Renishaw plc. Renishaw product names, designations and the mark 'apply innovation' are trade marks of Renishaw plc or its subsidiaries. Other brand, product or company names are trade marks of their respective owners.
Renishaw plc. Registered in England and Wales. Company no: 1106260. Registered office: New Mills, Wotton-under-Edge, Glos, GL12 8JR, UK.

WHILE CONSIDERABLE EFFORT WAS MADE TO VERIFY THE ACCURACY OF THIS DOCUMENT AT PUBLICATION, ALL WARRANTIES, CONDITIONS, REPRESENTATIONS AND LIABILITY, HOWSOEVER ARISING, ARE EXCLUDED TO THE EXTENT PERMITTED BY LAW. RENISHAW RESERVES THE RIGHT TO MAKE CHANGES TO THIS DOCUMENT AND TO THE EQUIPMENT, AND/OR SOFTWARE AND THE SPECIFICATION DESCRIBED HEREIN WITHOUT OBLIGATION TO PROVIDE NOTICE OF SUCH CHANGES.

Part no.: M-5225-0568-08-A
Issued: 06.2026