

Modular metrology fixturing

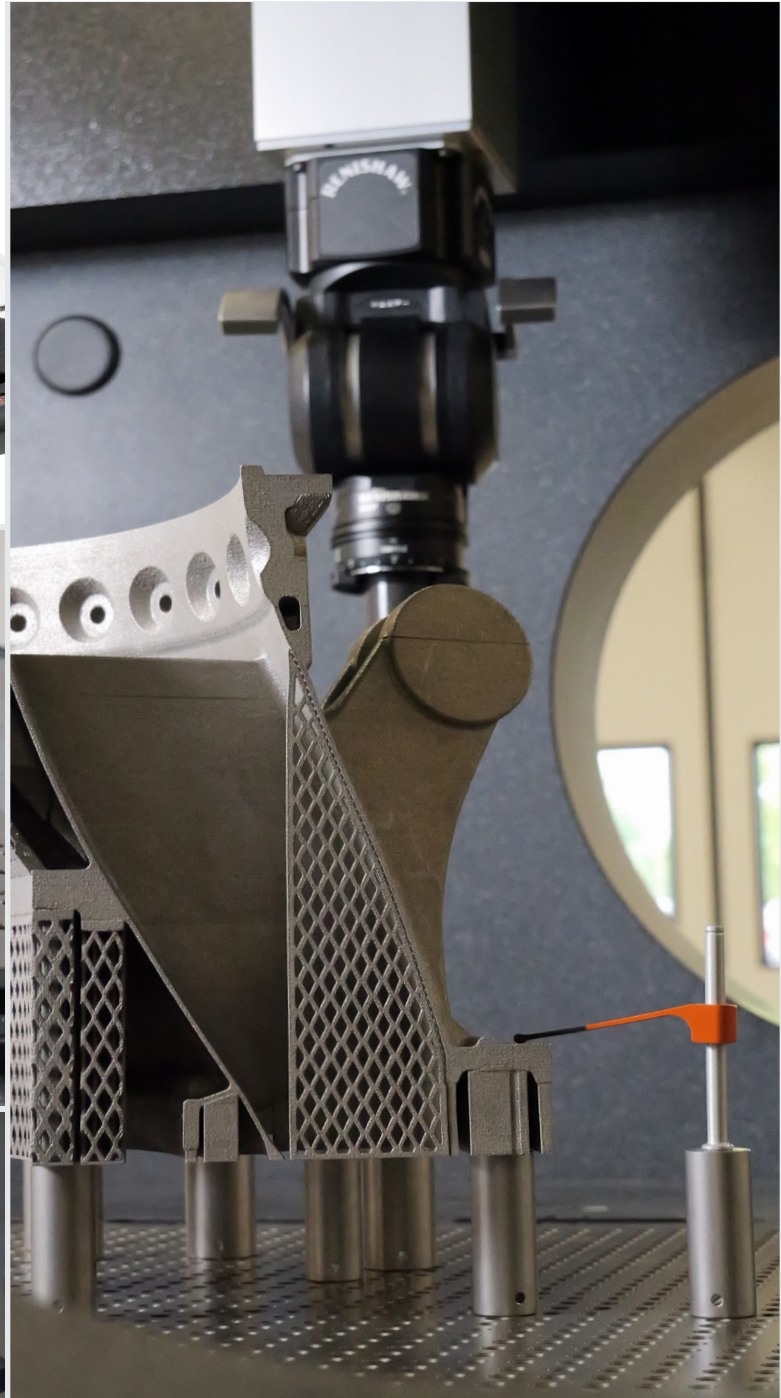

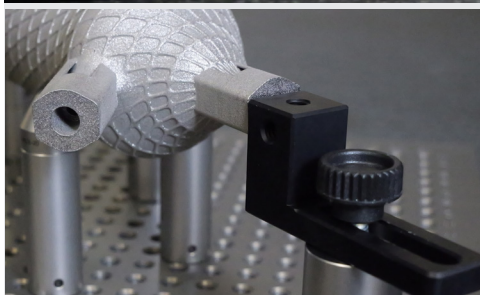

Browse and buy components and accessories online 24/7, at www.renishaw.com/shop

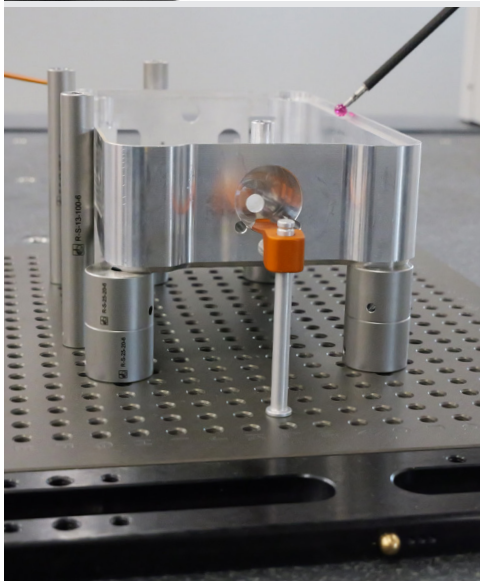

**Do you have any questions or want to discuss your metrology fixturing solution further?
Get in touch with our sales office on (UK) +44 (0) 1453 524524 or (USA) +1847 286 9953**



Find our digital catalogue and more product information online, at www.renishaw.com/fixtures

Contents

Your partner in precision	7
Welcome to Renishaw	7
Considerations for building a modular fixturing system	8
Size and number of workpieces that require inspection	8
Type of inspection method used	8
Critical features and workpiece material	8
Do I need a mounting system?	8
Do I need any specific components?	8
How to choose your fixturing system	9
Tactile measurement systems (CMM and Equator™ gauging systems)	9
Vision measurement systems	9
Mounting systems	10
Standard sized metrology fixture tables	10
Mounting systems for tactile measurement	11
QuickLoad™ rails	11
QuickLoad™ plates	11
Base plates for AGILITY® CMM systems	12
CMM base plates	13
ZEISS CMM base plates	14
Equator™ 300 gauging system base plates	14
Equator-X™ and Equator 500 gauging system base plates	14
Equator-X™ adaptor plate	15
Mounting systems for vision measurement	15
QuickLoad™ corners	15
Vision base plates	16
Fixturing component sets	18
Select your thread size	18
Choose your application	18
Choose the size of your set	18
Add additional sets	18
Component sets for tactile measurements	19
M4 metrology fixturing component set	19
M6 metrology fixturing component sets	20
M6 metrology fixturing add-on component sets: Magnetic	21
M6 metrology fixturing add-on component sets: Standoffs	21

M8 metrology fixturing component sets	22
M8 metrology fixturing add-on component sets: Magnetic	23
M8 metrology fixturing add-on component sets: Standoffs	23
1/4-20 metrology fixturing component sets	24
1/4-20 metrology fixturing add-on component sets: Magnetic	25
1/4-20 metrology fixturing add-on component sets: Standoffs	25
Component sets for vision measurement	26
M4 vision fixturing component sets	26
M6 vision fixturing component sets	27
1/4-20 vision fixturing component sets	28
Replacement fixturing component set cases (without components)	28
Modular fixturing components	30
Adjustables	30
Adjustable jack stands	30
Adjustable pivot joints	30
Adjustable slides	31
Adjustable acrylic slides	31
Adjustable height stands	32
Adjustable V-posts	32
Adjustable slide mirrors	33
Adjustable slide acrylic extension	33
Rotational micro Vs	34
Adjustable angle plates	35
Adjustable micro V	35
Chucks	37
3-jaw chuck	37
Rotating 3-jaw chuck	37
Clamps	38
Tension clamps	38
Soft tip tension clamps	39
Spring wire clamps	39
Soft tip spring wire clamps	40
Plunger tip tension clamps	40
Screw pusher clamp	41
Pusher clamps	41
Micro vice clamps	42
Mini vices	42

Tension clamp brackets	43
Centres	43
Micro centre	44
Micro V spring clamp	44
Rotational angle vice	45
Spring pusher standoff clamps	45
CMM plate clamp	46
Hold down clamps	46
Magnets	48
Magnetic standoffs	48
Magnetic pin standoffs	48
Magnetic mini V block	49
V magnets	49
Miscellaneous	51
Cones	51
Resting pins	51
Wedge stops	52
Screws and adaptors	52
Corner viewers	53
Vertical base plate	53
Micro V block	53
Tooling balls	54
Metrology table adaptor plate	54
Standoffs	56
Pin standoffs	58
Polyoxymethylene (POM) standoffs	59
POM pin standoffs	59
Standoff adaptors	60
Rotator standoffs	60
Towers	62
Tower blocks	63
Trays	65
Medium component tray	65
Small component tray	65
Component storage box	65
3D fixture modelling software	66

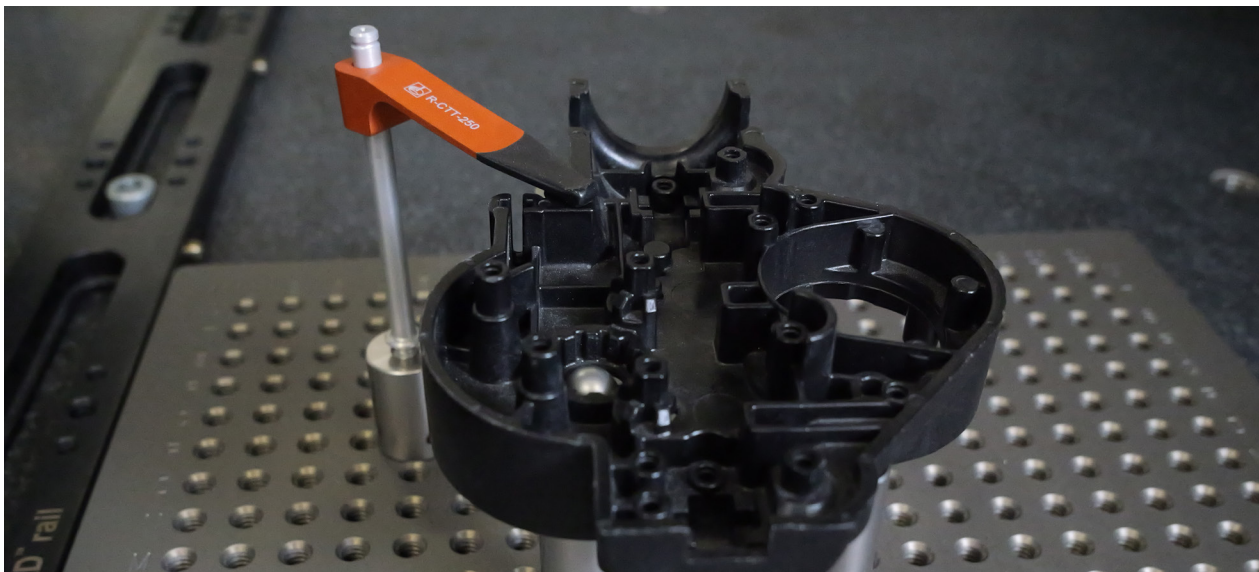
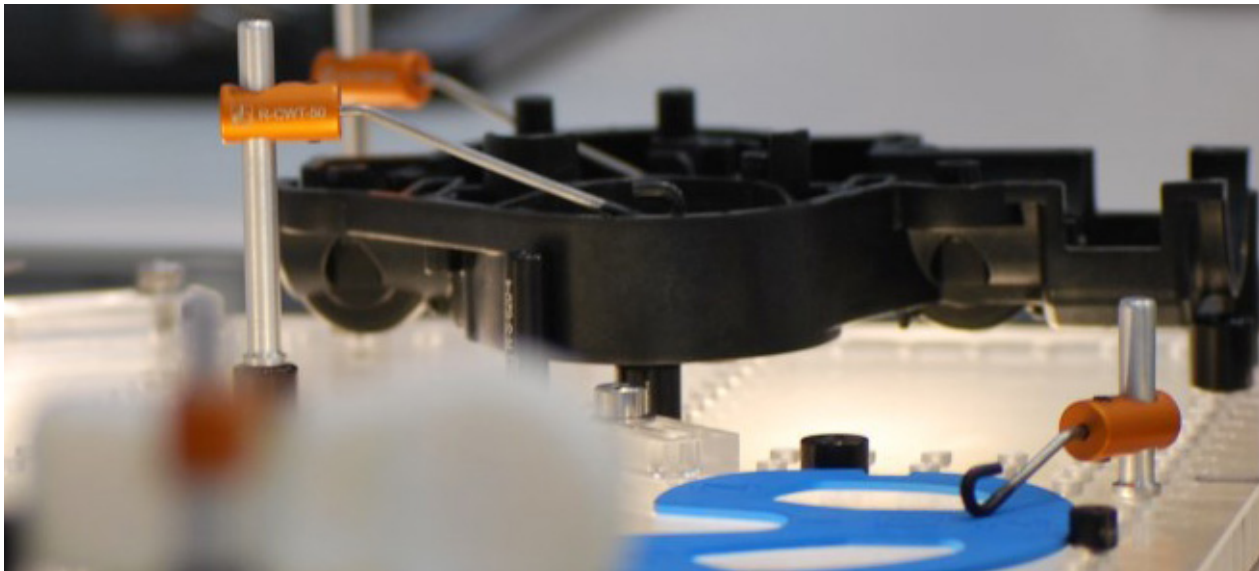
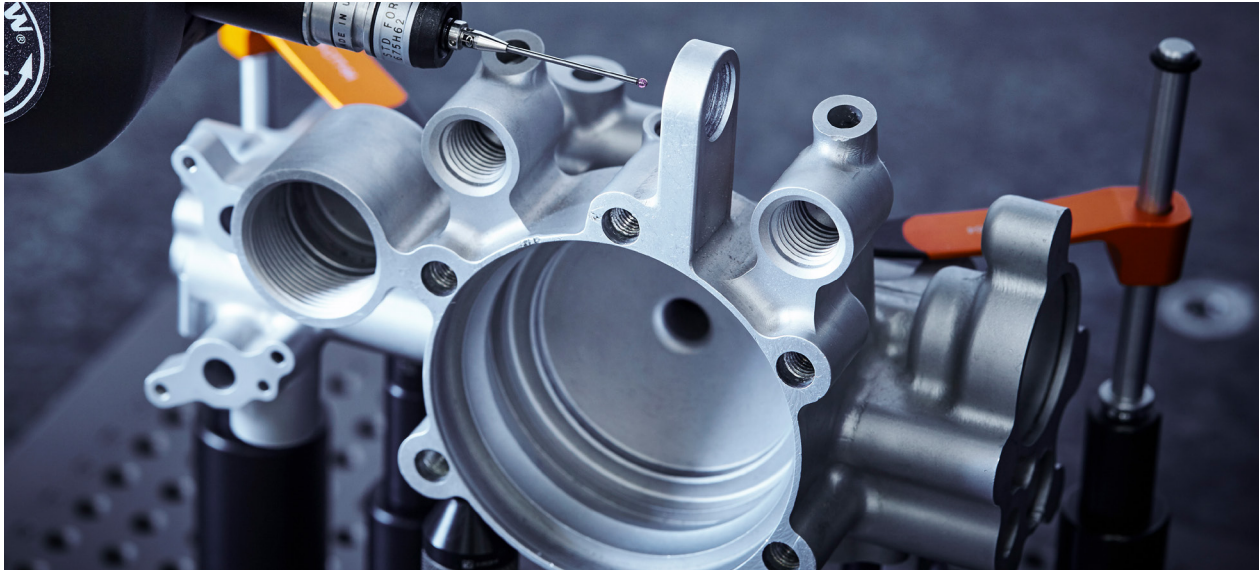

Your partner in precision

Welcome to Renishaw

Renishaw is one of the world's leading engineering and scientific technology companies, with expertise in precision measurement and healthcare. We supply products and services used in applications as diverse as jet engine and wind turbine manufacture, through to 3D printing and brain surgery.

We recognise the complexities involved with fixturing for inspection, so we have developed a product line that provides a reliable and repeatable foundation for measurement - a complete solution to your fixturing requirements.

Our easy-to-use modular fixturing range minimises time spent during one-off and repeat part inspection. This can be used with our software, FixtureBuilder, to build a fixture which can be exported into other CAD software and to auto-generate a set of assembly instructions. Your local sales representative can give you more information about FixtureBuilder.

“ We have a fundamental belief that metrology isn't just an eliminator of variation but an enabler of new capabilities.

Sir David McMurtry, Co-founder, Renishaw **”**

Considerations for building a modular fixturing system

There are several items to consider when specifying a full modular fixturing system:

Size and number of workpieces that require inspection

The size of the workpiece will determine which thread size (M4, M6, M8 or 1/4-20) to use. Typically smaller and lighter workpieces require M4, whilst larger, heavier workpieces may require M8. If a variety of workpieces require multiple fixtures to be built at the same time then a larger component set may be required.

Type of inspection method used

Renishaw offers fixturing components that are suitable for both vision and tactile measurement systems, including co-ordinate measuring machines (CMMs) and Equator™ gauging systems. Metrology tables can be used for CMM arm-based applications and laser scanning technologies.

Critical features and workpiece material

Ferrous workpieces can use the magnetic fixturing components to aid workpiece holding, whereas lightweight plastic workpieces may require low force wire clamps to make sure parts are held in their free state. Certain material types may be more susceptible to part marking and therefore polyoxymethylene (POM) components may be preferred over steel.

Do I need a mounting system?

Renishaw QuickLoad™ rails and corners can be used for repeatable placement of base plates on CMM and vision machines.

Do I need any specific components?

Certain features or workpiece types may need specialised components, such as centres, vices, and clamps.

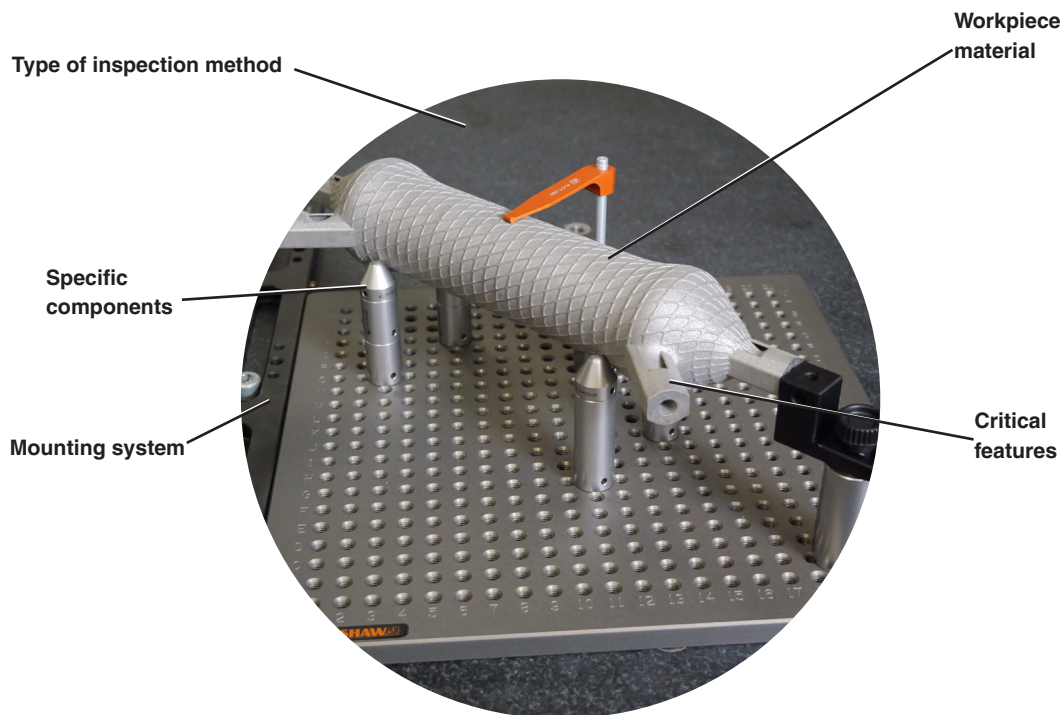

How to choose your fixturing system

It's easy to get started and build your own fixturing system using the simple steps below.

NOTE: You can model your fixtures with Renishaw's FixtureBuilder, easy to use 3D fixture modelling software. See page 66

Tactile measurement systems (CMM and Equator™ gauging systems)

Step 1: Choose a base and mounting system

CMM and Equator base plates provide a platform to begin construction of fixtures. Specific plates are available for AGILITY CMMs.

The QuickLoad system is fast, repeatable and helps the user to set up workpieces for inspection on multiple plates easily, before loading them to the rail efficiently to maximise throughput.

Step 2: Choose a component set

Component sets are offered in various sizes and thread types to suit a wide range of applications. Magnetic component add-on sets are available for ferrous workpieces.

Step 3: Choose any additional fixturing components

Vision measurement systems

Step 1: Choose a base and mounting system

QuickLoad corners come in multiple form factors, each designed to fit specific models of vision machine. Our acrylic base plates contain steel location points to align precisely onto magnets within the QuickLoad corner. This allows quick, easy and repeatable loading and unloading of plates on to the machine. There are two base plate types to choose from:

Multi-hole: which offers greater flexibility to set up and check as many parts as possible in a single inspection cycle, with a clear area in the centre of the plate.

Multi-window: with more windows for the clearest view of small parts.

Step 2: Choose a component set

Vision component sets contain smaller M4 threads which are most suitable for lighter and more flexible workpieces.

Step 3: Choose any additional fixturing components

Additional vision components can be bought separately and used alongside the preconfigured component set. Fixturing components are easily adjustable and designed to hold workpieces firmly with the minimum necessary force to avoid damage or distortion. The wide range of components available offers flexibility when setting up a fixture to ensure a clear path for inspection.

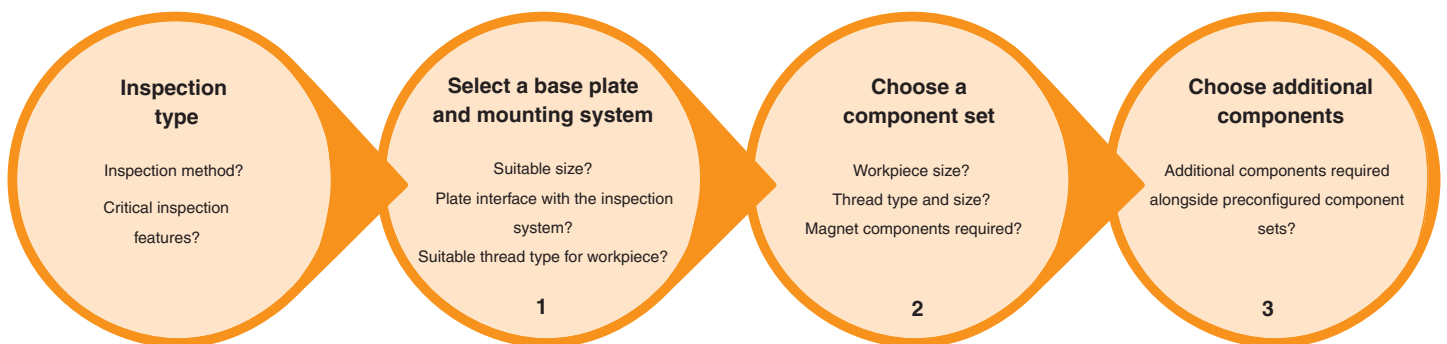

NOTE: Unless otherwise stated, dimensions are nominal and a general tolerance of ± 0.25 mm applies.

Mounting systems

Standard sized metrology fixture tables

Renishaw offers a standard range of metrology tables, which are made to be transportable with locking wheels. Metrology tables are compatible with portable CMMs, scanning systems and articulating arms.

Every table comes complete with our precision machined base plates for easy mounting of fixturing components and workpieces.

The standard range is shown below. In addition, bespoke tables are available with customised: length, width, height, hole pattern arrangements, shelving, drawers or black anodized plates (for light sensing applications).

For more information, contact your local Renishaw representative.

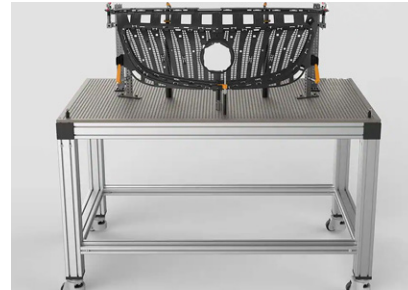

Part number	Thread	Dimensions (L x W)	Hole spacing	Weight*
R-TM-1200900-25-6	M6	1200 mm x 900 mm	25.0 mm	112 kg
R-TM-1200900-30-8	M8	1200 mm x 900 mm	30.0 mm	112 kg
R-TM-1500900-25-6	M6	1500 mm x 900 mm	25.0 mm	131 kg
R-TM-1500900-30-8	M8	1500 mm x 900 mm	30.0 mm	131 kg
R-TM-18001200-25-6	M6	1800 mm x 1200 mm	25.0 mm	183 kg
R-TM-18001200-30-8	M8	1800 mm x 1200 mm	30.0 mm	183 kg
R-TM-4735-1-20	1/4-20	35.43 in x 47.24 in	1.00 in	246.9 lb
R-TM-5935-1-20	1/4-20	35.43 in x 59.06 in	1.00 in	288.8 lb
R-TM-7147-1-20	1/4-20	47.24 in x 70.87 in	1.00 in	403.4 lb

NOTE: Tables are 900 mm/36 in high. *Weight of combined table and plate.

NOTE: Order a universal adaptor plate R-PAACU to fit any articulating arm to your metrology table (see page 54).

Mounting systems for tactile measurement

QuickLoad™ rails

Part number	Thread	Thickness	Width	Length
R-QLR-1350450	M4/M6/M8	12.5 mm	50.0 mm	450.0 mm
R-QLR-1350600	M4/M6/M8	12.5 mm	50.0 mm	600.0 mm
R-QLR2-1350600 (2 rails)	M4/M6/M8	12.5 mm	50.0 mm	600.0 mm
R-QLR-50218	1/4-20	0.50 in	2.00 in	18.00 in
R-QLR-50224	1/4-20	0.50 in	2.00 in	24.00 in
R-QLR2-50224 (2 rails)	1/4-20	0.50 in	2.00 in	24.00 in

NOTE: All QuickLoad rails come with locating washers and M6, M8, M10, M12 and 1/4-20 cap head screws.

QuickLoad™ plates

Part number	Thread	Height	Width	Thickness	Hole spacing on centre (OC)
R-QLPC-13150150-12-6	M6	12.7 mm	150.0 mm	150.0 mm	12.5 mm
R-QLPC-13300300-12-6	M6	12.7 mm	300.0 mm	300.0 mm	12.5 mm
R-QLPC-13450450-12-6	M6	12.7 mm	450.0 mm	450.0 mm	12.5 mm
R-QLPC-13300300-15-8	M8	12.7 mm	300.0 mm	300.0 mm	15.0 mm
R-QLPC-13450450-15-8	M8	12.7 mm	450.0 mm	450.0 mm	15.0 mm
R-QLPC-5066-50-20	1/4-20	0.50 in	6.00 in	6.00 in	0.50 in
R-QLPC-501212-50-20	1/4-20	0.50 in	12.00 in	12.00 in	0.50 in
R-QLPC-501818-50-20	1/4-20	0.50 in	18.00 in	18.00 in	0.50 in

Base plates for AGILITY® CMM systems

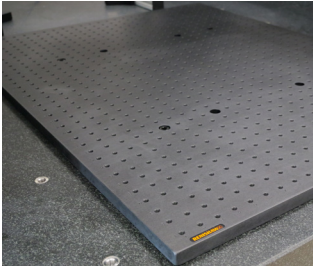

Part number	Thread	AGILITY model(s)	Plates per set	Height	Width	Thickness	Spacing (on centre)
M6 plates							
R-PC-796-6	M6	S 796 / L 796	1	19.1 mm	700.0 mm	900.0 mm	25.0 mm
R-PC-9158-6	M6	S 9158 / L 9185	1	19.1 mm	900.0 mm	1500.0 mm	25.0 mm
R-PC-12129-6	M6	S 12129	1	19.1 mm	1200.0 mm	1200.0 mm	25.0 mm
R-PC-12209-6	M6	S 12209	2	19.1 mm	1200.0 mm	996.0 mm	25.0 mm
R-PC-162412-6	M6	S 162412	2	19.1 mm	1600.0 mm	996.0 mm	25.0 mm
R-PC-555-6	M6	L 555	1	19.1 mm	500.0 mm	500.0 mm	25.0 mm
R-PC-122010-6	M6	L 122010	2	19.1 mm	900.0 mm	1500.0 mm	25.0 mm
R-PC-122410-6	M6	L 122410	2	19.1 mm	1200.0 mm	996.0 mm	25.0 mm
R-PC-123010-6	M6	L 123010	3	19.1 mm	1200.0 mm	1196.0 mm	25.0 mm
R-PC-162012-6	M6	L 162012	2	19.1 mm	1600.0 mm	996.0 mm	25.0 mm
R-PC-162412-6	M6	L 162412	2	19.1 mm	1600.0 mm	996.0 mm	25.0 mm
R-PC-163512-6	M6	L 163512	3	19.1 mm	1600.0 mm	996.0 mm	25.0 mm
M8 plates							
R-PC-796-8	M8	S 796 / L 796	1	19.1 mm	700.0 mm	900.0 mm	30.0 mm
R-PC-9158-8	M8	S 9158 / L 9158	1	19.1 mm	900.0 mm	1500.0 mm	30.0 mm
R-PC-12129-8	M8	S 12129	1	19.1 mm	1200.0 mm	1200.0 mm	30.0 mm
R-PC-12209-8	M8	S 12209	2	19.1 mm	1200.0 mm	996.0 mm	30.0 mm
R-PC-162412-8	M8	S 162412	2	19.1 mm	1600.0 mm	996.0 mm	30.0 mm
R-PC-555-8	M8	L 555	1	19.1 mm	500.0 mm	500.0 mm	30.0 mm
R-PC-122010-8	M8	L 122010	2	19.1 mm	900.0 mm	1500.0 mm	30.0 mm
R-PC-122410-8	M8	L 122410	2	19.1 mm	1200.0 mm	996.0 mm	30.0 mm
R-PC-123010-8	M8	L 123010	3	19.1 mm	1200.0 mm	1196.0 mm	30.0 mm
R-PC-162012-8	M8	L 162012	2	19.1 mm	1600.0 mm	996.0 mm	30.0 mm
R-PC-162412-8	M8	L 162412	2	19.1 mm	1600.0 mm	996.0 mm	30.0 mm
R-PC-163512-8	M8	L 163512	3	19.1 mm	1600.0 mm	996.0 mm	30.0 mm
1/4-20 plates							
R-PC-796-20	1/4-20	S 796 / L 796	1	0.75 in	27.55 in	35.43 in	1.00 in
R-PC-9158-20	1/4-20	S 9158 / L 9158	1	0.75 in	35.43 in	59.10 in	1.00 in
R-PC-12129-20	1/4-20	S 12129	1	0.75 in	47.24 in	47.24 in	1.00 in
R-PC-12209-20	1/4-20	S 12209	2	0.75 in	47.24 in	39.21 in	1.00 in
R-PC-162412-20	1/4-20	S 162412	2	0.75 in	62.99 in	39.21 in	1.00 in
R-PC-555-20	1/4-20	L 555	1	0.75 in	19.69 in	19.69 in	1.00 in
R-PC-122010-20	1/4-20	L 122010	2	0.75 in	27.53 in	35.43 in	1.00 in
R-PC-122410-20	1/4-20	L 122410	2	0.75 in	47.24 in	47.10 in	1.00 in
R-PC-123010-20	1/4-20	L 123010	3	0.75 in	47.24 in	39.21 in	1.00 in

Part number	Thread	AGILITY model(s)	Plates per set	Height	Width	Thickness	Spacing (on centre)
R-PC-162012-20	1/4-20	L 162012	2	0.75 in	62.99 in	39.21 in	1.00 in
R-PC-162412-20	1/4-20	L 162412	2	0.75 in	62.99 in	39.21 in	1.00 in
R-PC-163512-20	1/4-20	L 163512	3	0.75 in	62.99 in	39.21 in	1.00 in

NOTE: If a replacement plate, from a set, is required as a one off, contact your local sales representative.

CMM base plates



Part number	Thread	Height	Width	Thickness	Spacing (on centre)
M4 plates					
R-PC-13150150-10-4	M4	12.7 mm	150.0 mm	150.0 mm	10.0 mm
R-PC-13300300-10-4	M4	12.7 mm	300.0 mm	300.0 mm	10.0 mm
M6 plates					
R-PC-13150150-12-6	M6	12.7 mm	150.0 mm	150.0 mm	12.5 mm
R-PC-13300300-12-6	M6	12.7 mm	300.0 mm	300.0 mm	12.5 mm
R-PC-13450450-12-6	M6	12.7 mm	450.0 mm	450.0 mm	12.5 mm
R-PC-19600600-12-6	M6	19.1 mm	600.0 mm	600.0 mm	12.5 mm
R-PC-19750750-12-6	M6	19.1 mm	750.0 mm	750.0 mm	12.5 mm
R-PC-197501000-12-6	M6	19.1 mm	750.0 mm	1000.0 mm	12.5 mm
R-PC-199001200-12-6	M6	19.1 mm	900.0 mm	1200.0 mm	12.5 mm
M8 plates					
R-PC-13300300-15-8	M8	12.7 mm	300.0 mm	300.0 mm	15.0 mm
R-PC-13450450-15-8	M8	12.7 mm	450.0 mm	450.0 mm	15.0 mm
R-PC-19600600-15-8	M8	19.1 mm	600.0 mm	600.0 mm	15.0 mm
R-PC-19750750-15-8	M8	19.1 mm	750.0 mm	750.0 mm	15.0 mm
R-PC-197501020-15-8	M8	19.1 mm	750.0 mm	1020.0 mm	15.0 mm
R-PC-199001200-15-8	M8	19.1 mm	900.0 mm	1200.0 mm	15.0 mm
1/4-20 plates					
R-PC-5066-50-20	1/4-20	0.50 in	6.00 in	6.00 in	0.50 in
R-PC-501212-50-20	1/4-20	0.50 in	12.00 in	12.00 in	0.50 in
R-PC-501818-50-20	1/4-20	0.50 in	18.00 in	18.00 in	0.50 in
R-PC-752424-50-20	1/4-20	0.75 in	24.00 in	24.00 in	0.50 in
R-PC-752840-50-20	1/4-20	0.75 in	28.00 in	40.00 in	0.50 in
R-PC-753030-50-20	1/4-20	0.75 in	30.00 in	30.00 in	0.50 in
R-PC-753648-50-20	1/4-20	0.75 in	36.00 in	48.00 in	0.50 in

NOTE: Ask your local sales representative about the custom plates with bolt holes available.

ZEISS CMM base plates

Part number	Thread	Height	Width	Thickness	Spacing (on centre)	Mounting hole spacing
R-PCZ2-13450450-12-6	M6	12.7 mm	450.0 mm	450.0 mm	12.5 mm	2 holes at 400 mm
R-PCZ4-19750750-12-6	M6	19.1 mm	750.0 mm	750.0 mm	12.5 mm	4 holes at 600 mm
R-PC-Z2-501818-50-20	1/4-20	0.50 in	18.00 in	18.00 in	0.50 in	2 holes at 400 mm
R-PC-Z4-753030-50-20	1/4-20	0.75 in	30.00 in	30.00 in	0.50 in	4 holes at 600 mm

Equator™ 300 gauging system base plates

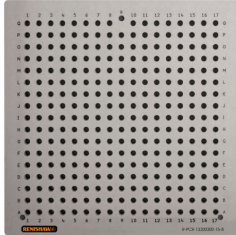

Part number	Thread	Height	Width	Thickness	Spacing
R-PCR-13300300-12-6	M6	12.7 mm	300.0 mm	300.0 mm	12.5 mm
R-PCR-13300300-15-8	M8	12.7 mm	300.0 mm	300.0 mm	15.0 mm

NOTE: Thickness does not include kinematic pins.

Equator-X™ and Equator 500 gauging system base plates



Part number	Thread	Height	Width	Thickness	Spacing
R-PCX-10510510-25-6	M6	10.0 mm	510.0 mm	510.0 mm	25.0 mm
R-PCX-10510510-30-8	M8	10.0 mm	510.0 mm	510.0 mm	30.0 mm
R-PCX-402020-1-20	1/4-20	0.40 in	20.10 in	20.10 in	1.00 in

Equator-X™ adaptor plate

A low-profile adaptor plate for Equator-X™ 500 that features a repeatable kinematic interface. This allows for rapid and reliable mounting of existing Equator 300 tiles on an Equator-X 500 gauge, thereby enabling rapid changeover between multi-hole Equator-X 500 plates and tile-based fixtures.



Part number	Height	Width	Thickness
R-PCX-53ADPT	10.0 mm	510.0 mm	510.0 mm

Mounting systems for vision measurement

QuickLoad™ corners

For rapid, repeatable positioning of Renishaw acrylic plates on vision and multi-sensor machine stages. All corners are black anodised aluminium and include nylon tipped screws to avoid marking the glass on the staging platforms.

Part number	Bolt hole thread	Compatible with
R-QLC-KIM7030	M4	Keyence IM-7030
R-QLC-MVVX861061212	M6	Micro-Vu Vertex-210, -251, -311, -312, -410, -420, -341, -342
R-QLC-MVE500-600	M6	Micro-Vu Excel-501, -502, -511, -512, -651, -652, -654, -661, -662, -664, -701, -702, -704
R-QLC-NIN-VMA2520	M6	Nikon iNEXIV VMA-2520
R-QLC-OF200-302Q300	M6	OGP SmartScope: FLASH 302, QUEST 300, VANTAGE 300, Flash CNC 300, Specialist 300, Flare 200
R-QLC-OGPF500-625	M6	OGP SmartScope: FLASH 500, CNC 500, FLASH 620
R-QLC-OGPSZFQ250M200	M6	OGP SmartScope: CNC 250, FLASH 250, QUEST 250, VANTAGE 250, ZIP 250, ZIP Lite 250; OGP: SparkMVP 250, SprintMVP 250, StarLite 250; (Not OGP) VIEW Benchmark 300
R-QLC-OSZ-MAF-RS300	M6	OGP SmartScope: CNC 300, FLASH 302, Flash CNC 300, ZIP 300, ZIP Lite 300; OGP: SprintMVP 300, Avant 300, SparkMVP 300, StarLite 300
R-QLC-SMVRVR200-300	M4	Starrett: MVR 200, MVR 300, AVR 200, AVR 300
R-QLC-ZO3-4-5-LR	M6	ZEISS O-Inspect 322, 442, 543, 863; Schut DeMeet-404, -443

NOTE: Standard QuickLoad corners are designed to be mounted on the lower left corner of the system. Products with LR suffix are designed to be mounted in the lower right corner of the system.

NOTE: Contact your local sales representative for the custom QuickLoad corner options available.

Vision base plates

Part number	Thread	Height	Width	Thickness	Windows	Spacing (on centre)
M4 multi-hole plates						
R-PV-13150150-10-4	M4	12.0 mm	150.0 mm	150.0 mm	1	10.0 mm
R-PV-13200200-10-4	M4	12.0 mm	200.0 mm	200.0 mm	1	10.0 mm
R-PV-13250150-10-4	M4	12.0 mm	250.0 mm	150.0 mm	1	10.0 mm
R-PV-13250250-10-4	M4	12.0 mm	250.0 mm	250.0 mm	1	10.0 mm
R-PV-13300200-10-4	M4	12.0 mm	300.0 mm	200.0 mm	1	10.0 mm
R-PV-13300300-10-4	M4	12.0 mm	300.0 mm	300.0 mm	1	10.0 mm
R-PV-13400400-10-4	M4	12.0 mm	400.0 mm	400.0 mm	1	10.0 mm
R-PV-13200200-10-4R*	M4	12.0 mm	200.0 mm	200.0 mm	1	10.0 mm
R-PV-13250150-10-4R*	M4	12.0 mm	250.0 mm	150.0 mm	1	10.0 mm
R-PV-13250250-10-4R*	M4	12.0 mm	250.0 mm	250.0 mm	1	10.0 mm
R-PV-13300200-10-4R*	M4	12.0 mm	300.0 mm	200.0 mm	1	10.0 mm
M4 multi-window plates						
R-PVMW-13150150-10-4	M4	12.0 mm	150.0 mm	150.0 mm	4	10.0 mm
R-PV-W-13200200-10-4	M4	12.0 mm	200.0 mm	200.0 mm	5	10.0 mm
R-PV-W-13250150-10-4	M4	12.0 mm	250.0 mm	150.0 mm	3	10.0 mm
R-PV-W-13250250-10-4	M4	12.0 mm	250.0 mm	250.0 mm	5	10.0 mm
R-PVW-13300200-10-4	M4	12.0 mm	300.0 mm	200.0 mm	3	10.0 mm
R-PVW-13300300-10-4	M4	12.0 mm	300.0 mm	300.0 mm	8	10.0 mm
R-PV-W-13400400-10-4	M4	12.0 mm	400.0 mm	400.0 mm	7	10.0 mm
R-PVW-13200200-10-4R*	M4	12.0 mm	200.0 mm	200.0 mm	5	10.0 mm
R-PVW-13250150-10-4R*	M4	12.0 mm	250.0 mm	150.0 mm	3	10.0 mm
R-PVW-13250250-10-4R*	M4	12.0 mm	250.0 mm	250.0 mm	5	10.0 mm
R-PVW-13300200-10-4R*	M4	12.0 mm	300.0 mm	200.0 mm	3	10.0 mm
M6 multi-hole plates						
R-PV-13150150-12-6	M6	12.0 mm	150.0 mm	150.0 mm	1	12.5 mm
R-PV-13250250-12-6	M6	12.0 mm	250.0 mm	250.0 mm	1	12.5 mm
M6 multi-window plates						
R-PV-W-13250150-12-6	M6	12.0 mm	250.0 mm	150.0 mm	4	12.5 mm
R-PV-W-13250250-12-6	M6	12.0 mm	250.0 mm	250.0 mm	5	12.5 mm
R-PV-W-13400400-12-6	M6	12.0 mm	400.0 mm	400.0 mm	7	12.5 mm
1/4-20 multi-hole plates						
R-PV-501010-50-20	1/4-20	0.47 in	10.00 in	10.00 in	1	0.50 in
R-PV-50128-50-20	1/4-20	0.47 in	12.00 in	8.00 in	1	0.50 in
R-PV-501616-50-20	1/4-20	0.47 in	16.00 in	16.00 in	1	0.50 in
R-PV-501010-50-20R*	1/4-20	0.47 in	10.00 in	10.00 in	1	0.50 in
R-PV-501212-50-20R*	1/4-20	0.47 in	12.00 in	12.00 in	1	0.50 in
1/4-20 multi-window plates						
R-PV-W-50106-50-20	1/4-20	0.47 in	10.00 in	6.00 in	4	0.50 in
R-PV-W-501010-50-20	1/4-20	0.47 in	10.00 in	10.00 in	5	0.50 in
R-PVW-50128-50-20	1/4-20	0.47 in	12.00 in	8.00 in	4	0.50 in
R-PV-W-501616-50-20	1/4-20	0.47 in	16.00 in	16.00 in	7	0.50 in
R-PVW-501010-50-20R*	1/4-20	0.47 in	10.00 in	10.00 in	5	0.50 in
R-PVW-501212-50-20R*	1/4-20	0.47 in	12.00 in	12.00 in	6	0.50 in

NOTE: *The letter R at the end of a part number means that the plate is designed for use with a lower-right mounting QLC.

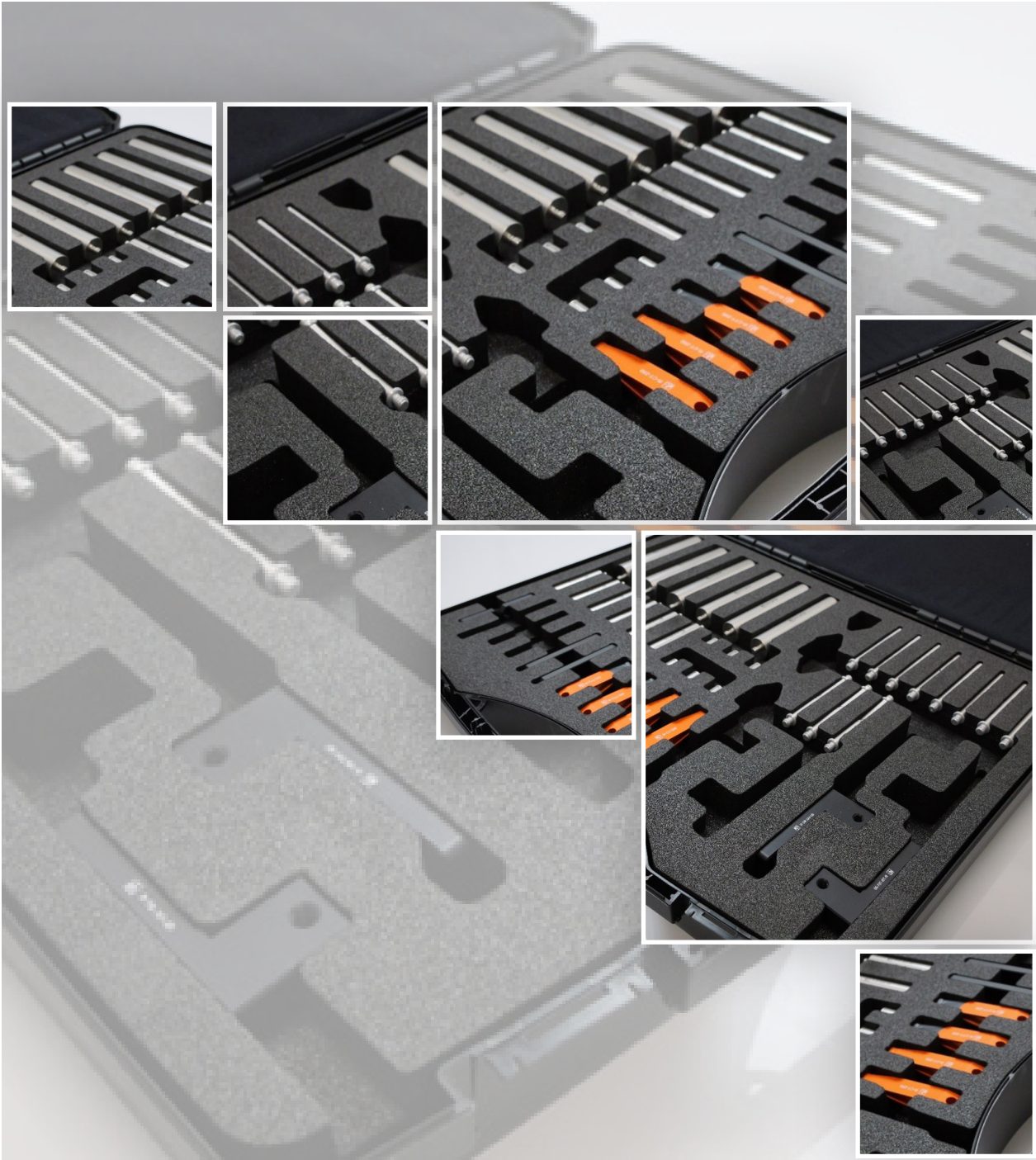

Fixturing component sets

Renishaw's modular fixturing component sets come with a variety of fixturing components to get you started with fixturing and enable you to fixture a large variety of workpieces.

Our fixturing component sets can be used for every industrial metrology application including: CMM, Equator™ vision, multi-sensor, light applications and with your metrology table.

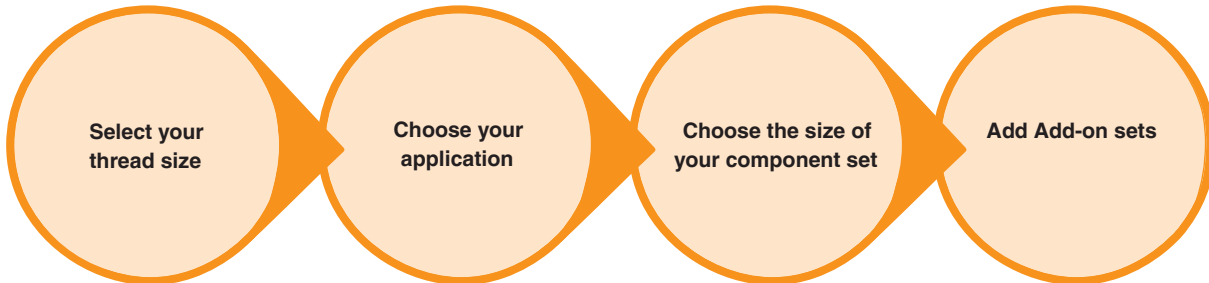

Select your thread size

Choose from

- M4 (Aluminium standoffs—recommended for desktop vision systems and smaller intricate workpieces).
- M6, M8 or 1/4-20 (Stainless steel standoffs—recommended for most metrology systems and larger heavier workpieces).

Choose your application

Renishaw offer and recommend dedicated fixturing component sets for the following applications:

- Tactile measurement—these component sets have everything you need to get started with fixturing your workpieces for inspection on CMMs or Equator gauging systems.
- Vision—dedicated fixture sets for securing smaller workpieces in a vision application.

Choose the size of your set

Every fixturing component set comes complete with a storage/carry case. Fixturing component sets start with a price sensitive, starter option. This starter component set is for users who wish to try our fixturing component sets. Sets progress in size and number of components all the way up to a professional option. The professional component set provides a robust flexible solution allowing you to create multiple fixtures for many workpieces at once.



Add additional sets

To further enhance your fixturing capabilities you may choose to also add an add-on component set. Add-on component sets provide you with options to increase the flexibility and capacity of your fixturing. Add-on component sets are available as follows:

- Magnetic—to fixture ferrous workpieces.
- Standoff—additional sets can be added to your fixture set to increase the number of fixtures you can create at any one time.

Component sets for tactile measurements

Renishaw component sets allow you to start fixturing quickly and easily. Our sets have carefully considered fixturing components for creating repeatable, fast, and precise modular fixtures.

As with our fixturing plates and metrology tables, component sets come in standard thread sizes of M4, M6, M8 and 1/4-20.

Each fixturing component set comes in a protective carry case for safe transportation and to provide storage.

Component sets are available in the following configurations: starter, basic, intermediate or professional.

You can further enhance your fixturing capabilities with a magnetic and/or standoff add-on set.



M4 metrology fixturing component set

Part number	Description	Basic R-C-SET-BSC-4
R-S-610-4*	6.0 mm diameter × 10.0 mm standoff	3
R-S-625-4*	6.0 mm diameter × 25.0 mm standoff	3
R-S-95-4*	9.0 mm diameter × 5.0 mm standoff	3
R-S-910-4	9.0 mm diameter × 10.0 mm standoff	3
R-S-925-4	9.0 mm diameter × 25.0 mm standoff	3
R-S-950-4	9.0 mm diameter × 50.0 mm standoff	2
R-S-1210-4	12.0 mm diameter × 10.0 mm standoff	3
R-S-1225-4	12.0 mm diameter × 25.0 mm standoff	3
R-S-1250-4	12.0 mm diameter × 50.0 mm standoff	2
R-SP-610-4	6.0 mm diameter × 10.0 mm pin standoff	2
R-SP-910-4	9.0 mm diameter × 10.0 mm pin standoff	2
R-CT-40-25-4	36.2 mm tension clamp with 25.0 mm post	2
R-CTT-40-25-4	36.2 mm tension clamp with coated soft tip and 25.0 mm post	2
R-CW-50-50-4	49.7 mm wire clamp with 50.0 mm post	2
R-CSPS-1210-4	Spring pusher standoff clamp	1
R-RPA-4	Aluminium resting pin	4
R-AJ-9-4	9.5 mm diameter adjustable jack stand	1
R-AS-30-4	30.1 mm diameter adjustable slide	1
R-AS-45-4	45.0 mm long adjustable slide	1
R-TB-1619-4	41.3 mm × 15.9 mm × 25.0 mm tower block	1
–	Storage and carry case	1
Total number of components in each set		45

NOTE: *Component does not have a threaded top.

M6 metrology fixturing component sets

Part number	Description	Starter R-C-SET-STR-6	Basic R-C-SET-BSC-6	Intermediate R-C-SET-INT-6	Professional R-C-SET-PRO-6
R-S-910-6	9.5 mm diameter × 10.0 mm standoff	–	–	–	4
R-S-925-6	9.5 mm diameter × 25.0 mm standoff	–	–	–	4
R-S-1310-6	12.7 mm diameter × 10.0 mm standoff	–	–	6	10
R-S-1320-6	12.7 mm diameter × 20.0 mm standoff	2	4	6	12
R-S-1325-6	12.7 mm diameter × 25.0 mm standoff	2	4	6	8
R-S-1350-6	12.7 mm diameter × 50.0 mm standoff	3	4	6	8
R-S-1910-6	19.1 mm diameter × 10.0 mm standoff	–	–	3	4
R-S-1920-6	19.1 mm diameter × 20.0 mm standoff	2	4	9	12
R-S-1925-6	19.1 mm diameter × 25.0 mm standoff	2	4	9	12
R-S-1950-6	19.1 mm diameter × 50.0 mm standoff	3	4	9	12
R-S-19100-6	19.1 mm diameter × 100.0 mm standoff	–	–	3	10
R-S-2525-6	25.4 mm diameter × 25.0 mm standoff	–	–	3	4
R-S-2550-6	25.4 mm diameter × 50.0 mm standoff	–	–	3	4
R-S-25100-6	25.4 mm diameter × 100.0 mm standoff	–	–	3	4
R-SP-1325-6	12.7 mm diameter × 25.0 mm pin standoff	2	2	4	4
R-SP-1925-6	19.1 mm diameter × 25.0 mm pin standoff	–	–	–	2
R-CT-40-30-6	36.2 mm tension clamp with 30.0 mm post	–	–	4	4
R-CT-64-70-6	57.5 mm tension clamp with 68.1 mm post	2	2	4	6
R-CTT-40-30-6	36.2 mm tension clamp with rubber coated tip with 30.0 mm post	–	2	2	2
R-CTT-64-70-6	57.5 mm tension clamp with rubber coated tip with 68.1 mm post	–	–	4	4
R-CT-95-83-6	87.7 mm tension clamp with 82.8 mm post	–	–	–	3
R-RCS-19-6	Steel resting cone	–	4	4	6
R-RCD-19-6	POM resting cone	4	4	4	6
R-RPS-6	Steel resting pin	–	–	4	6
R-WS-915-6	15.0 mm diameter wedge stop	–	–	–	3
R-APJ-6	Adjustable pivot joint	–	–	–	1
R-AJ-13-6	15.9 mm diameter adjustable jack stand	1	1	2	4
R-AJ-25-6	25.4 mm diameter adjustable jack stand	–	–	2	3
R-AS-45-6	44.5 mm long adjustable slide	2	1	2	3
R-AS-70-6	72.0 mm long adjustable slide	–	1	2	4
R-TB-2025-6	70 mm × 20 mm × 35 mm tower block	–	–	2	2
R-CSPS-1925-6	19.1 mm diameter × 25.0 mm spring pusher standoff clamp	1	1	1	2
R-AVP-2525-6	25.0 mm diameter × 25.0 mm adjustable V-post	–	–	–	2
–	Various screws - as per set requirements	1	1	1	1
R-TT	Loosening tools	2	2	2	2
–	Storage and carry case	1	1	1	2
Total number of components in each set		30	46	111	180

M6 metrology fixturing add-on component sets: Magnetic

Part number	Description	Magnetic set R-M-SET-BSC-6 Basic	Magnetic set R-M-SET-INT-6 Intermediate
R-M-13-6	12.7 mm diameter × 25.0 mm magnet	3	6
R-M-19-6	19.1 mm diameter × 25.0 mm magnet	3	6
R-M-25-6	25.4 mm diameter × 25.0 mm magnet	3	6
R-MP-13-6	12.7 mm diameter × 25.0 mm pin magnet	2	2
R-MP-19-6	19.1 mm diameter × 25.0 mm pin magnet	–	2
R-MV-19-6	19.1 mm diameter × 25.0 mm V magnet	–	2
–	Storage and carry case	1	1
Total number of components in each set		12	25

M6 metrology fixturing add-on component sets: Standoffs

Part number	Description	Standoff set R-S-SET-BSC-6 Basic
R-S-1310-6	12.7 mm diameter × 10.0 mm standoff	2
R-S-1320-6	12.7 mm diameter × 20.0 mm standoff	4
R-S-1325-6	12.7 mm diameter × 25.0 mm standoff	4
R-S-1350-6	12.7 mm diameter × 50.0 mm standoff	4
R-S-1920-6	19.1 mm diameter × 20.0 mm standoff	4
R-S-1925-6	19.1 mm diameter × 25.0 mm standoff	4
R-S-1950-6	19.1 mm diameter × 50.0 mm standoff	4
R-S-19100-6	19.1 mm diameter × 100.0 mm standoff	2
R-S-2525-6	25.4 mm diameter × 25.0 mm standoff	1
R-S-2550-6	25.4 mm diameter × 50.0 mm standoff	1
R-S-25100-6	25.4 mm diameter × 100.0 mm standoff	1
R-TT	Loosening tools	2
–	Storage and carry case	1
Total number of components in each set		34

M8 metrology fixturing component sets

Part number	Description	Starter R-C-SET-STR-8	Basic R-C-SET-BSC-8	Intermediate R-C-SET-INT-8	Professional R-C-SET-PRO-8
R-S-1315-8	12.7 mm diameter × 15.0 mm standoff	–	–	3	10
R-S-1320-8	12.7 mm diameter × 20.0 mm standoff	2	4	6	12
R-S-1325-8	12.7 mm diameter × 25.0 mm standoff	2	4	6	8
R-S-1350-8	12.7 mm diameter × 50.0 mm standoff	3	4	6	8
R-S-1915-8	19.1 mm diameter × 15.0 mm standoff	–	–	3	12
R-S-1920-8	19.1 mm diameter × 20.0 mm standoff	2	4	9	12
R-S-1925-8	19.1 mm diameter × 25.0 mm standoff	2	4	9	12
R-S-1950-8	19.1 mm diameter × 50.0 mm standoff	3	4	9	12
R-S-19100-8	19.1 mm diameter × 100.0 mm standoff	–	–	3	10
R-S-2525-8	25.4 mm diameter × 25.0 mm standoff	–	–	3	4
R-S-2550-8	25.4 mm diameter × 50.0 mm standoff	–	–	3	4
R-S-25100-8	25.4 mm diameter × 100.0 mm standoff	–	–	3	4
R-SP-1325-8	12.7 mm diameter × 25.0 mm pin standoff	2	2	4	4
R-SP-1925-8	19.1 mm diameter × 25.0 mm pin standoff	–	–	–	2
R-CT-40-30-8	36.2 mm tension clamp with 30.0 mm post	–	–	4	4
R-CT-64-70-8	57.5 mm tension clamp with 68.1 mm post	2	2	4	6
R-CTT-40-30-8	36.2 mm tension clamp with rubber coated tip with 30.0 mm post	–	2	2	2
R-CTT-64-70-8	57.5 mm tension clamp with 68.1 mm post	–	–	4	4
R-CT-95-83-8	87.7 mm tension clamp with 82.8 mm post	–	–	–	3
R-RCS-19-8	Steel resting cone	–	4	4	6
R-RCS-25-8	25.0 mm diameter steel resting cone	–	–	4	6
R-RCD-19-8	POM resting cone	4	4	4	6
R-WS-1316-8	19.1 mm diameter wedge stop	–	–	–	3
R-APJ-8	Adjustable pivot joint	–	–	–	1
R-AJ-19-8	19.0 mm diameter adjustable jack stand	1	1	2	4
R-AJ-25-8	25.4 mm diameter adjustable jack stand	–	–	2	3
R-AS-45-8	44.5 mm long adjustable slide	2	1	2	3
R-AS-70-8	71.9 mm long adjustable slide	–	1	2	4
R-TB-2530-8	88.9 mm × 25.0 mm × 40.0 mm tower block	–	–	2	2
R-CSPS-1925-8	19.1 mm diameter × 25.0 mm spring pusher standoff clamp	1	1	1	2
R-AVP-2525-8	25.0 mm diameter × 25.0 mm adjustable V post	–	–	–	2
–	Various screws - as per set requirements	1	1	1	1
R-TT	Loosening tools	2	2	2	2
–	Storage and carry case	1	1	1	2
Total number of components in each set		30	46	111	180

M8 metrology fixturing add-on component sets: Magnetic

Part number	Description	Magnetic set R-M-SET-BSC-8 Basic	Magnetic set R-M-SET-INT-8 Intermediate
R-M-13-8	12.7 mm diameter × 25.0 mm magnet	3	6
R-M-19-8	19.1 mm diameter × 25.0 mm magnet	3	6
R-M-25-8	25.4 mm diameter × 25.0 mm magnet	3	6
R-MP-13-8	12.7 mm diameter × 25.0 mm pin magnet	2	2
R-MP-19-8	19.1 mm diameter × 25.0 mm pin magnet	–	2
R-MV-19-8	19.1 mm diameter × 25.0 mm V magnet	–	2
–	Storage and carry case	1	1
Total number of components in each set		12	25

M8 metrology fixturing add-on component sets: Standoffs

Part number	Description	Standoff set R-S-SET-BSC-8 Basic
R-S-1315-8	12.7 mm diameter × 15.0 mm standoff	2
R-S-1320-8	12.7 mm diameter × 20.0 mm standoff	4
R-S-1325-8	12.7 mm diameter × 25.0 mm standoff	4
R-S-1350-8	12.7 mm diameter × 50.0 mm standoff	4
R-S-1920-8	19.1 mm diameter × 20.0 mm standoff	4
R-S-1925-8	19.1 mm diameter × 25.0 mm standoff	4
R-S-1950-8	19.1 mm diameter × 50.0 mm standoff	4
R-S-19100-8	19.1 mm diameter × 100.0 mm standoff	2
R-S-2525-8	25.4 mm diameter × 25.0 mm standoff	1
R-S-2550-8	25.4 mm diameter × 50.0 mm standoff	1
R-S-25100-8	25.4 mm diameter × 100.0 mm standoff	1
R-TT	Loosening tools	2
–	Storage and carry case	1
Total number of components in each set		34

1/4-20 metrology fixturing component sets

Part number	Description	Starter R-C-SET-STR-20	Basic R-C-SET-BSC-20	Intermediate R-C-SET-INT-20	Professional R-C-SET-PRO-20
R-S-2550-20	0.25 in diameter × 0.50 in standoff	–	–	–	4
R-S-251-20	0.25 in diameter × 1.00 in standoff	–	–	–	4
R-S-5050-20	0.50 in diameter × 0.50 in standoff	–	–	6	10
R-S-5075-20	0.50 in diameter × 0.75 in standoff	2	4	6	12
R-S-501-20	0.50 in diameter × 1.00 in standoff	2	4	6	8
R-S-502-20	0.50 in diameter × 2.00 in standoff	3	4	6	8
R-S-7550-20	0.75 in diameter × 0.50 in standoff	–	–	3	4
R-S-7575-20	0.75 in diameter × 0.75 in standoff	2	4	9	12
R-S-751-20	0.75 in diameter × 1.00 in standoff	2	4	9	12
R-S-752-20	0.75 in diameter × 2.00 in standoff	3	4	9	12
R-S-754-20	0.75 in diameter × 4.00 in standoff	–	–	3	10
R-S-11-20	1.00 in diameter × 1.00 in standoff	–	–	3	4
R-S-12-20	1.00 in diameter × 2.00 in standoff	–	–	3	4
R-S-14-20	1.00 in diameter × 4.00 in standoff	–	–	3	4
R-SP-501-20	0.50 in diameter × 1.00 in pin standoff	2	2	4	4
R-SP-751-20	0.75 in diameter × 1.00 in pin standoff	–	–	–	2
R-CT-160-125-20	1.43 in tension clamp with 1.26 in post	–	–	4	4
R-CT-250-275-20	2.26 in tension clamp with 2.76 in post	2	2	4	6
R-CTT-160-125-20	1.43 in tension clamp with 1.26 in post	–	2	2	2
R-CTT-250-275-20	2.26 in tension clamp with rubber coated tip with 2.76 in post	–	–	4	4
R-CT-375-325-20	3.45 in tension clamp with 3.26 in post	–	–	–	3
R-RCS-75-20	Steel resting cone	–	4	4	6
R-RCD-75-20	POM resting cone	4	4	4	6
R-RPS-20	Steel resting pin	–	–	4	6
R-WS-37550-20	0.57 in diameter wedge stop	–	–	–	3
R-APJ-20	Adjustable pivot joint	–	–	–	1
R-AJ-50-20	0.63 in diameter adjustable jack stand	1	1	2	4
R-AJ-1-20	1.00 in diameter adjustable jack stand	–	–	2	3
R-AS-1-20	1.37 in long adjustable slide	2	1	2	3
R-AS-3-20	3.00 in long adjustable slide	–	1	2	4
R-TB-751-20	2.75 in × 0.75 in × 1.25 in tower block	–	–	2	2
R-CSPS-751-20	0.75 in diameter × 1.00 in spring pusher standoff clamp	1	1	1	2
R-AVP-11-20	1.00 in diameter × 1.00 in adjustable V post	–	–	–	2
–	Various screws - as per set requirements	1	1	1	1
R-TT	Loosening tools	2	2	2	2
–	Storage and carry case	1	1	1	2
Total number of components in each set		30	46	111	180

1/4-20 metrology fixturing add-on component sets: Magnetic

Part number	Description	Magnetic set R-M-SET-BSC-20 Basic	Magnetic set R-M-SET-INT-20 Intermediate
R-M-50-20	0.50 in diameter × 1.00 in magnet	3	6
R-M-75-20	0.75 in diameter × 1.00 in magnet	3	6
R-M-1-20	1.00 in diameter × 1.00 in magnet	3	6
R-MP-50-20	0.50 in diameter × 1.00 in pin magnet	2	2
R-MP-75-20	0.75 in diameter × 1.00 in pin magnet	–	2
R-MV-75-20	0.75 in diameter × 1.00 in V magnet	–	2
–	Storage and carry case	1	1
Total number of components in each set		12	25

1/4-20 metrology fixturing add-on component sets: Standoffs

Part number	Description	Standoff set R-S-SET-BSC-20 Basic
R-S-5050-20	0.50 in diameter × 0.50 in standoff	2
R-S-5075-20	0.50 in diameter × 0.75 in standoff	4
R-S-501-20	0.50 in diameter × 1.00 in standoff	4
R-S-502-20	0.50 in diameter × 2.00 in standoff	4
R-S-7575-20	0.75 in diameter × 0.75 in standoff	4
R-S-751-20	0.75 in diameter × 1.00 in standoff	4
R-S-752-20	0.75 in diameter × 2.00 in standoff	4
R-S-754-20	0.75 in diameter × 4.00 in standoff	2
R-S-11-20	1.00 in diameter × 1.00 in standoff	1
R-S-12-20	1.00 in diameter × 2.00 in standoff	1
R-S-14-20	1.00 in diameter × 4.00 in standoff	1
R-TT	Loosening tools	2
–	Storage and carry case	1
Total number of components in each set		34

Component sets for vision measurement

M4 vision fixturing component sets

NOTE: Make sure that the acrylic plate and QuickLoad corner you select will fit your specific machine. Contact your local sales representative to discuss your requirements.

Part number	Description	Basic R-V-SET-BSC-4	Intermediate R-V-SET-INT-4
R-S-65-4*	6.0 mm diameter × 5.0 mm standoff	–	3
R-S-610-4*	6.0 mm diameter × 10.0 mm standoff	3	6
R-S-625-4*	6.0 mm diameter × 25.0 mm standoff	3	6
R-S-95-4*	9.0 mm diameter × 5.0 mm standoff	3	3
R-S-910-4	9.0 mm diameter × 10.0 mm standoff	3	6
R-S-920-4	9.0 mm diameter × 20.0 mm standoff	3	6
R-S-925-4	9.0 mm diameter × 25.0 mm standoff	3	6
R-S-1210-4	12.0 mm diameter × 10.0 mm standoff	3	6
R-S-1225-4	12.0 mm diameter × 25.0 mm standoff	3	6
R-SP-610-4	6.0 mm diameter × 10.0 mm pin standoff	2	4
R-SP-910-4	9.0 mm diameter × 10.0 mm pin standoff	2	4
R-CTT-40-25-4	36.2 mm tension clamp with coated soft tip and 25.0 mm post	2	4
R-CWT-25-25-4	31.3 mm wire clamp with coated soft tip and 25.0 mm post	2	4
R-CWT-50-50-4	49.7 mm wire clamp with coated soft tip and 50.0 mm post	2	4
R-CP-4	Pusher clamp	1	1
R-NTM-1	Magnetic V block	–	1
R-CSPS-1210-4	Spring pusher standoff clamp	1	1
R-RPA-4	Aluminium resting pin	4	4
R-VC-5050-4	50.0 mm × 50.0 mm corner viewer	1	1
R-AJ-9-4	9.5 mm diameter adjustable jack stand	1	2
R-AS-30-4	30.1 mm long adjustable slide	1	2
R-ASA-45-4	45.0 mm long adjustable acrylic slide	1	2
R-TB-1619-4	41.3 mm × 15.9 mm × 25.0 mm tower block	1	1
–	Storage and carry case	1	1
Total number of components in each set		46	84

NOTE: *Component does not have a threaded top.

M6 vision fixturing component sets

NOTE: Make sure that the acrylic plate and QuickLoad corner you select will fit your specific machine. Contact your local sales representative to discuss your requirements.

Part number	Description	Basic R-V-SET-BSC-6	Intermediate R-V-SET-INT-6
R-S-610-6*	6.0 mm diameter × 10.0 mm standoff	3	6
R-S-625-6*	6.0 mm diameter × 25.0 mm standoff	3	6
R-S-95-6*	9.5 mm diameter × 5.0 mm standoff	3	6
R-S-910-6	9.5 mm diameter × 10.0 mm standoff	3	6
R-S-920-6	9.5 mm diameter × 20.0 mm standoff	3	6
R-S-925-6	9.5 mm diameter × 25.0 mm standoff	3	6
R-S-1310-6	12.7 mm diameter × 10.0 mm standoff	3	6
R-S-1325-6	12.7 mm diameter × 25.0 mm standoff	3	6
R-SP-610-6	6.4 mm diameter × 10.0 mm pin standoff	2	4
R-SP-910-6	9.5 mm diameter × 10.0 mm pin standoff	2	4
R-CTT-40-30-6	36.2 mm tension clamp with coated soft tip and 30.0 mm post	2	4
R-CWT-25-25-6	31.3 mm wire clamp with coated soft tip and 23.9 mm post	2	4
R-CWT-50-50-6	49.7 mm wire clamp with coated soft tip and 50.0 mm post	2	4
R-CP-6	Pusher clamp	1	1
R-NTM-1	Magnetic V block	–	1
R-CSPS-1925-6	19.0 mm diameter × 25.0 mm spring pusher standoff clamp	1	1
R-RPS-6	Steel resting pin	4	4
R-VC-7575-6	82.6 mm × 82.6 mm corner viewer	1	1
R-AJ-13-6	15.9 mm diameter adjustable jack stand	1	2
R-AS-45-6	44.5 mm long adjustable slide	1	2
R-ASA-45-6	50.8 mm long adjustable acrylic slide base	1	2
R-TB-2025-6	70 mm × 20 mm × 35 mm tower block	1	1
–	Storage and carry case	1	1
Total number of components in each set		46	84

NOTE: *Component does not have a threaded top.

1/4-20 vision fixturing component sets

NOTE: Make sure that the acrylic plate and QuickLoad corner you select will fit your specific machine. Contact your local sales representative to discuss your requirements.

Part number	Description	Basic R-V-SET-BSC-20	Intermediate R-V-SET-INT-20
R-S-2550-20*	0.25 in diameter × 0.50 in standoff	3	6
R-S-251-20*	0.25 in diameter × 1.00 in standoff	3	6
R-S-37525-20*	0.375 in diameter × 0.25 in standoff	3	6
R-S-37550-20	0.375 in diameter × 0.50 in standoff	3	6
R-S-37575-20	0.375 in diameter × 0.75 in standoff	3	6
R-S-3751-20	0.375 in diameter × 1.00 in standoff	3	6
R-S-5050-20	0.50 in diameter × 0.50 in standoff	3	6
R-S-501-20	0.50 in diameter × 1.00 in standoff	3	6
R-SP-2550-20	0.25 in diameter × 0.50 in pin standoff	2	4
R-SP-37550-20	0.375 in diameter × 0.50 in pin standoff	2	4
R-CTT-160-125-20	1.42 in tension clamp with rubber-coated tip with 1.26 in post	2	4
R-CWT-1-1-20	1.23 in wire clamp with rubber-coated tip with 0.94 in post	2	4
R-CWT-2-2-20	1.96 in wire clamp with rubber-coated tip with 1.76 in post	2	4
R-NTM-1	Magnetic V block	—	1
R-RPS-20	Steel resting pin	4	4
R-VC-33-20	3.25 in × 3.25 in corner viewer	1	1
R-AJ-50-20	0.63 in diameter adjustable jack stand	1	2
R-CP-20	Pusher clamp	1	1
R-CSPS-751-20	0.75 in diameter × 1.00 in spring pusher standoff clamp	1	1
R-AS-1-20	1.37 in long adjustable slide	1	2
R-ASA-2-20	2.00 in long adjustable acrylic slide	1	2
R-TB-751-20	0.75 in × 0.75 in × 1.25 in tower block	1	1
—	Storage and carry case	1	1
Total number of components in each set		46	84

NOTE: *Component does not have a threaded top.

Replacement fixturing component set cases (without components)

Part number	Description	Compatible products
A-7253-3040	Clamping intermediate Clamping professional (case 1 of 2)	R-C-SET-INT-6, R-C-SET-INT-8, R-C-SET-INT-20 R-C-SET-PRO-6, R-C-SET-PRO-8, R-C-SET-PRO-20
A-7253-3041	Clamping professional (case 2 of 2)	R-C-SET-PRO-6, R-C-SET-PRO-8, R-C-SET-PRO-20
A-7253-3042	Vision intermediate	R-V-SET-INT-4, R-V-SET-INT-6, R-V-SET-INT-20
A-7253-3043	Vision basic	R-V-SET-BSC-4, R-V-SET-BSC-6, R-V-SET-BSC-20
A-7253-3044	Standoff basic	R-S-SET-BSC-6, R-S-SET-BSC-8, R-S-SET-BSC-20
A-7253-3045	Clamping basic	R-C-SET-BSC-4, R-C-SET-BSC-6, R-C-SET-BSC-8, R-C-SET-BSC-20
A-7253-3046	Clamping starter	R-C-SET-BSC-6, R-C-SET-BSC-8, R-C-SET-BSC-20
A-7253-3047	Magnetic basic Magnetic Intermediate	R-M-SET-BSC-6, R-M-SET-BSC-8, R-M-SET-BSC-20 R-M-SET-INT-6, R-M-SET-INT-8, R-M-SET-INT-20
A-7253-3048	Clamping professional (2 case set)	R-C-SET-PRO-6, R-C-SET-PRO-8, R-C-SET-PRO-20



Modular fixturing components

Adjustables

Allow for added flexibility when fixturing complex workpieces.

Adjustable jack stands

An adjustable jack stand allows variable heights and then locks the workpiece into position.

Part number	Material	Thread	Diameter	Height	Adjustment
R-AJ-9-4	Aluminium	M4	9.5 mm	19.3 mm	5.0 mm
R-AJ-19-6	Stainless steel	M6	19.1 mm	40.0 mm	15.0 mm
R-AJ-25-6	Stainless steel	M6	25.4 mm	40.0 mm	15.0 mm
R-AJ-19-8	Stainless steel	M8	19.1 mm	40.0 mm	15.0 mm
R-AJ-25-8	Stainless steel	M8	25.4 mm	40.0 mm	15.0 mm
R-AJ-38-8	Stainless steel	M8	38.1 mm	65.0 mm	25.0 mm
R-AJ-75-20	Stainless steel	1/4-20	0.75 in	1.575 in	0.59 in
R-AJ-1-20	Stainless steel	1/4-20	1.00 in	1.575 in	0.59 in



R-AJ-25-6

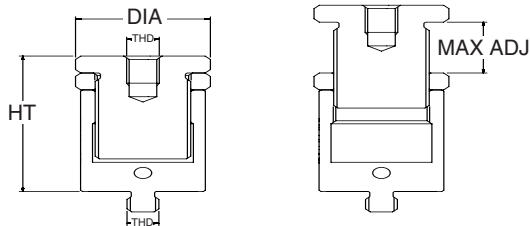

Adjustable pivot joints

To position a component at an angle, lock the rotating base into position and then set the angle of the pivot.

Part number	Material	Thread	Diameter	Height	Adjustment
R-APJ-6	Aluminium	M6	19.0 mm	50.7 mm	186°
R-APJ-8	Aluminium	M8	19.0 mm	50.7 mm	186°
R-APJ-20	Aluminium	1/4-20	0.75 in	2.00 in	186°



R-APJ-8

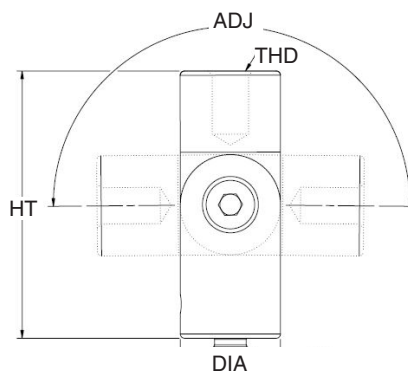

Adjustable slides

Adjustable slides can be used to place components in-between holes on the plate, or for locating workpieces.

Part number	Material	Thread	Height	A	B	C
R-AS-30-4	Aluminium	M4	5.0 mm	30.1 mm	12.7 mm	9.3 mm
R-AS-45-4	Aluminium	M4	5.0 mm	45.0 mm	12.7 mm	23.8 mm
R-AS-45-6	Aluminium	M6	10.0 mm	44.5 mm	20.0 mm	12.9 mm
R-AS-70-6	Aluminium	M6	10.0 mm	72.0 mm	25.0 mm	33.9 mm
R-AS-100-6	Aluminium	M6	10.0 mm	100.0 mm	25.0 mm	61.9 mm
R-AS-45-8	Aluminium	M8	10.0 mm	44.5 mm	20.0 mm	12.9 mm
R-AS-70-8	Aluminium	M8	10.0 mm	71.9 mm	25.0 mm	33.9 mm
R-AS-1-20	Aluminium	1/4-20	0.25 in	1.37 in	0.63 in	0.50 in
R-AS-3-20	Aluminium	1/4-20	0.25 in	3.00 in	1.00 in	1.50 in
R-AS-4-20	Aluminium	1/4-20	0.25 in	4.00 in	1.00 in	2.48 in

NOTE: Includes socket cap head, thumb screws and washer.



Adjustable acrylic slides

Adjustable acrylic slides can be used to place components in-between holes on the plate, or to push a workpiece into a corner in vision applications.

Part number	Material	Thread	Height	A	B	C
R-ASA-45-4	Acrylic	M4	5.0 mm	45.0 mm	12.7 mm	23.8 mm
R-ASA-45-6	Acrylic	M6	10.0 mm	50.8 mm	20.0 mm	28.6 mm
R-ASA-2-20	Acrylic	1/4-20	0.25 in	2.00 in	0.63 in	1.12 in

NOTE: Includes socket cap head thumb screws and washer.

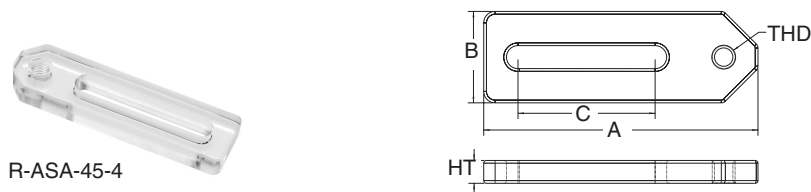

Adjustable height stands

Adjustable height stands allow variable heights without marking the part.

Part number	Material	Thread	Diameter	Height	Adjustment
R-AH-2545-6	POM	M6	25.4 mm	45.0 mm	14.2 mm
R-AH-2545-8	POM	M8	25.4 mm	45.0 mm	14.2 mm
R-AH-1175-20	POM	1/4-20	1.00 in	1.77 in	0.56 in



R-AH-2545-8

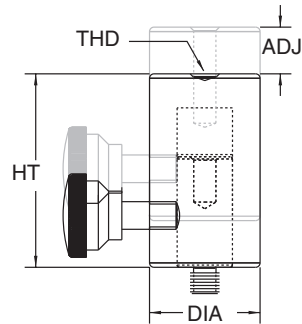

Adjustable V-posts

For holding cylindrical or tubular parts without marking the surface of the workpiece. They can be rotated and locked to any orientation.

Part number	Material	Thread	Diameter	Height	Adjustment
R-AVP-2525-6	POM	M6	25.1 mm	25.0 mm	360°
R-AVP-2525-8	POM	M8	25.1 mm	25.0 mm	360°
R-AVP-11-20	POM	1/4-20	0.99 in	1.00 in	360°

NOTE: Includes screw.



R-AVP-2525-6

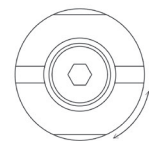
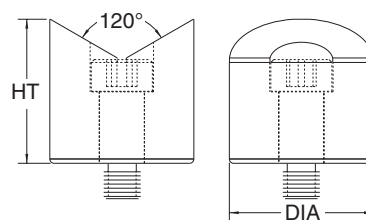

360° ADJ

Adjustable slide mirrors

Use an adjustable slide mirror to help view and inspect a workpiece.

Part number	Material	Thread	Height	A	B	C	D
R-ASM-4	Aluminium	M4	28.6 mm	75.0 mm	20.2 mm	30.0 mm	–
R-ASM-50-2	Aluminium	M4/M6/ 1/4-20	45.0 mm/ 1.77 in	95.0 mm/ 3.74 in	50.4 mm/ 1.98 in	31.8 mm/ 1.25 in	30.0 mm/ 1.18 in
R-ASM-100	Aluminium	M4/M6/ 1/4-20	89.6 mm/ 3.53 in	139.3 mm/ 5.49 in	108.0 mm/ 4.25 in	46.3 mm/ 1.82 in	44.2 mm/ 1.74 in



R-ASM-50-2

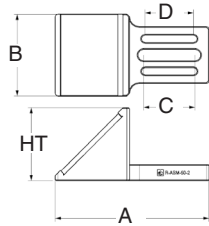

R-ASM-50-2



R-ASM-4

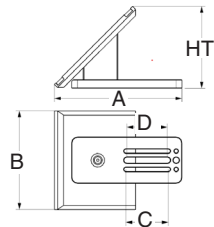
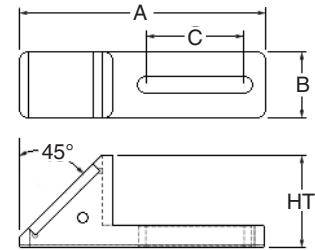

R-ASM-100

Adjustable slide acrylic extension

Screw any component onto the acrylic slide to extend the reach of the component. This can also be used to push workpieces into a corner in vision applications.

Part number	Material	Thread	Height	A	B	C	Adjustment
R-ASAE-4	Aluminium	M4	10.0 mm	82.3 mm	12.7 mm	25.4 mm	185°

NOTE: Includes socket cap head screws.



R-ASAE-4

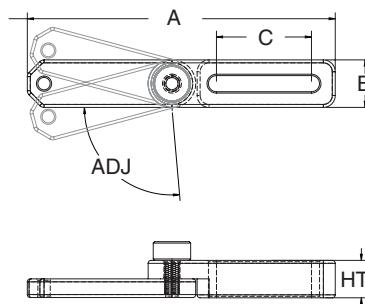

Rotational micro Vs

For holding small cylindrical or tubular workpieces with minimal surface contact.

Part number	Material	Thread	Height	A
R-VMR-1525-4	Aluminium	M4	26.4 mm	15.9 mm
R-VMR-1525-6	Aluminium	M6	26.4 mm	15.9 mm
R-VMR-631-20	Aluminium	1/4-20	1.04 in	0.63 in



R-VMR-1525-4

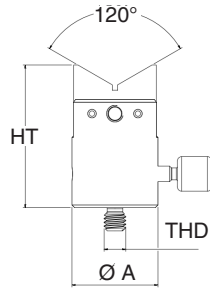

Adjustable angle plates

Ideal for holding components on an angle. The angle plate is adjustable to 180°.

Part number	Material	Thread	Height	A	B	C
R-PCA-135075-10-4	Aluminium	M4	25.4 mm	50.8 mm	76.2 mm	160°
R-PCA-135075-12-6	Aluminium	M6	25.4 mm	50.8 mm	76.2 mm	160°
R-PCA-135075-15-8	Aluminium	M8	25.4 mm	50.8 mm	76.2 mm	160°
R-PCA-5023-50-20	Aluminium	1/4-20	1.00 in	2.00 in	3.00 in	160°

C	D Ø
0°	–
5°	6.54 mm/0.258 in
10°	8.25 mm/0.325 in
15°	9.92 mm/0.39 in
20°	11.55 mm/0.455 in
25°	13.14 mm/0.518 in
30°	14.71 mm/0.579 in
35°	16.24 mm/0.64 in
40°	17.76 mm/0.699 in
45°	19.25 mm/0.758 in
50°	20.73 mm/0.816 in
55°	22.19 mm/0.873 in
60°	23.63 mm/0.93 in
65°	25.06 mm/0.986 in
70°	26.46 mm/1.042 in
75°	27.85 mm/1.096 in
80°	29.20 mm/1.15 in
85°	30.50 mm/1.201 in
90°	31.74 mm/1.25 in



R-PCA-135075-15-8

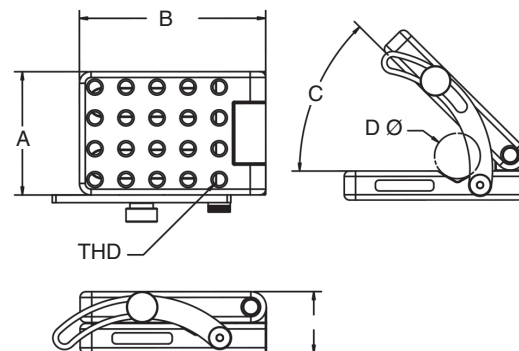

NOTE: Column D Ø can be used to set gauge pin angles.

Adjustable micro V

For cylindrical workpieces smaller than 6.5 mm in diameter.

Part number	Material	Thread	Height	A	B	C
R-AVM-4	Aluminium	M4	8.0 mm	25.7 mm	23.8 mm	11.0 mm



R-AVM-4

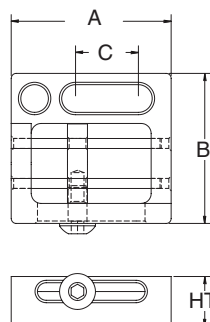

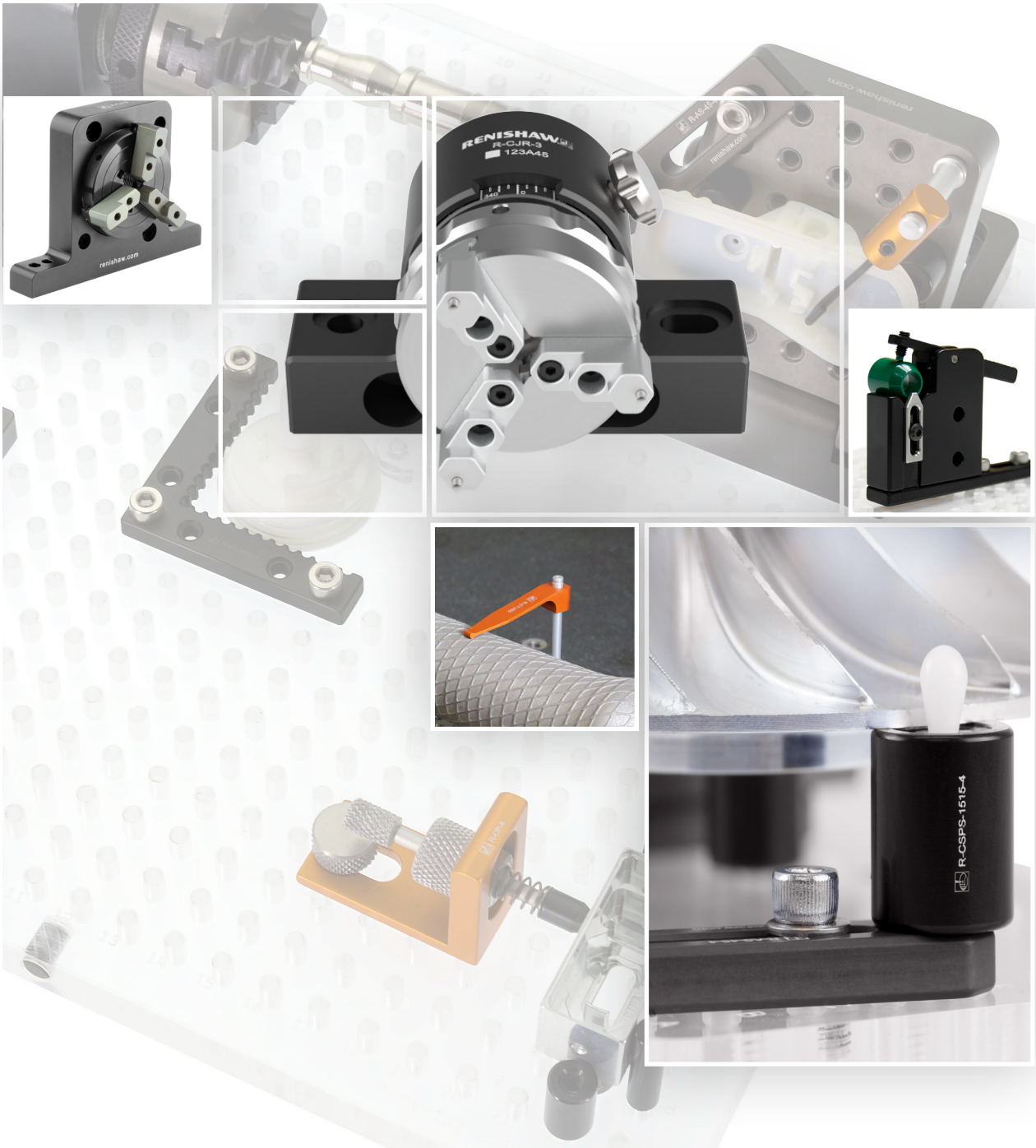

Chucks

A range of chucks to secure workpieces in place

3-jaw chuck

3-jaw chucks are for holding workpieces and have jaws that can be removed and reversed. Workpieces can be held by their outer diameter (OD) or inner diameter (ID). OD Min = 1.5 mm, OD Max = 64 mm, ID Min = 47 mm, ID Max = 64 mm.

Part number	Material	Thread	Height	A	B	C	D	Adjustments
R-CJ-3	Aluminium*	M6/ M8/ 1/4-20	126.2 mm/ 4.97 in	177.8 mm/ 7.00 in	56.3 mm/ 2.22 in	69.8 mm/ 2.75 in	19.0 mm/ 0.75 in	1.5 – 64.5 mm

NOTE: Includes socket cap head screws. *Jaws are aluminium. Chuck mechanism contains steel.

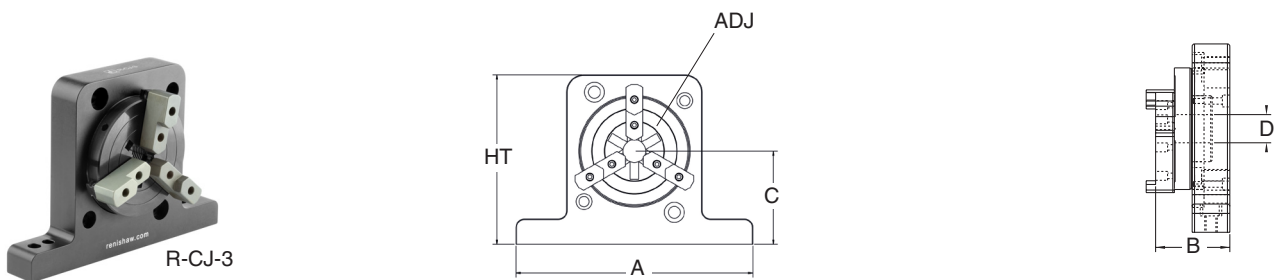

Rotating 3-jaw chuck

Use a rotating 3-jaw chuck for clamping on the inner or the outer diameter of the workpiece, then rotating to a marked increment and locking into position.

Part number	Material	Thread	Height	A	B	C	D	Adjustments
R-CJR-3	Aluminium*	M4/ M6/ 1/4-20	60.3 mm/ 2.37 in	101.6 mm/ 4.00 in	73.4 mm/ 2.89 in	38.1 mm/ 1.50 in	6.4 mm/ 0.25 in	1 – 63 mm

NOTE: Not intended for checking part runout. *Chuck body and jaws are steel.

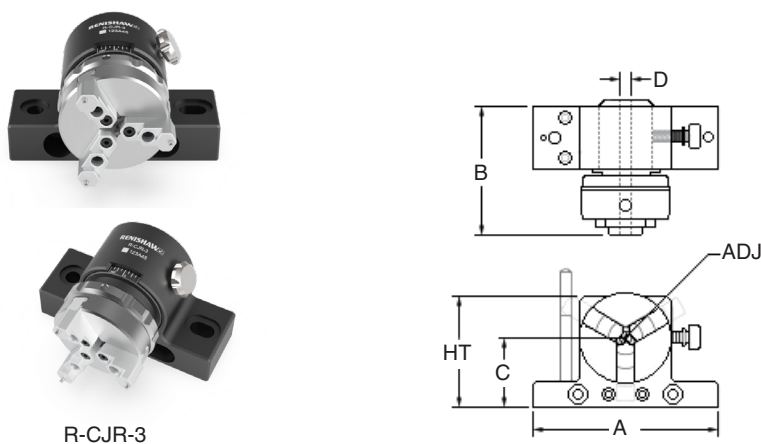

Clamps

A wide range of clamps to secure workpieces in place

Tension clamps

Use tension clamps for quick and easy clamping.

Part number	Material	Thread	Height	A	B	C
R-CT-40-25-4	Aluminium	M4	25.0 mm	36.2 mm	7.6 mm	3.9 mm
R-CT-40-30-6	Aluminium	M6	30.0 mm	36.2 mm	7.6 mm	3.9 mm
R-CT-40-70-6	Aluminium	M6	68.1 mm	36.2 mm	7.6 mm	3.9 mm
R-CT-64-70-6	Aluminium	M6	68.1 mm	57.5 mm	12.7 mm	5.3 mm
R-CT-95-83-6	Aluminium	M6	82.8 mm	87.7 mm	19.0 mm	8.6 mm
R-CT-40-30-8	Aluminium	M8	30.0 mm	36.2 mm	7.6 mm	3.9 mm
R-CT-40-70-8	Aluminium	M8	68.1 mm	36.2 mm	7.6 mm	3.9 mm
R-CT-64-70-8	Aluminium	M8	68.1 mm	57.5 mm	12.7 mm	5.3 mm
R-CT-95-83-8	Aluminium	M8	82.8 mm	87.7 mm	19.0 mm	8.6 mm
R-CT-160-125-20	Aluminium	1/4-20	1.26 in	1.43 in	0.30 in	0.15 in
R-CT-160-275-20	Aluminium	1/4-20	2.76 in	1.43 in	0.30 in	0.15 in
R-CT-250-275-20	Aluminium	1/4-20	2.76 in	2.26 in	0.50 in	0.21 in
R-CT-375-325-20	Aluminium	1/4-20	3.26 in	3.45 in	0.75 in	0.34 in

NOTE: Replacement arms and posts can be ordered separately. Contact your local sales representative.

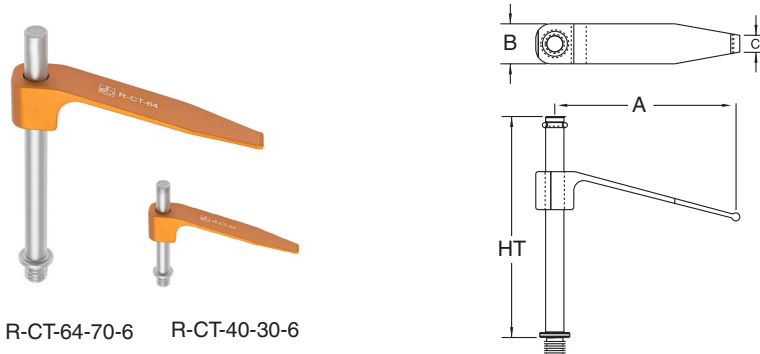

Soft tip tension clamps

Rubber-coated tips hold workpieces without scratching or marking the surface of a workpiece.

Part number	Material	Thread	Height	A	B	C
R-CTT-40-25-4	Aluminium	M4	25.0 mm	36.2 mm	7.6 mm	3.9 mm
R-CTT-40-30-6	Aluminium	M6	30.0 mm	36.2 mm	7.6 mm	3.9 mm
R-CTT-40-70-6	Aluminium	M6	68.1 mm	36.2 mm	7.6 mm	3.9 mm
R-CTT-64-70-6	Aluminium	M6	68.1 mm	57.5 mm	12.7 mm	5.3 mm
R-CTT-95-83-6	Aluminium	M6	82.8 mm	87.7 mm	19.0 mm	8.6 mm
R-CTT-40-30-8	Aluminium	M8	30.0 mm	36.2 mm	7.6 mm	3.9 mm
R-CTT-40-70-8	Aluminium	M8	68.1 mm	36.2 mm	7.6 mm	3.9 mm
R-CTT-64-70-8	Aluminium	M8	68.1 mm	57.5 mm	12.7 mm	5.3 mm
R-CTT-95-83-8	Aluminium	M8	82.8 mm	87.7 mm	19.0 mm	8.6 mm
R-CTT-160-125-20	Aluminium	1/4-20	1.26 in	1.42 in	0.30 in	0.15 in
R-CTT-160-275-20	Aluminium	1/4-20	2.76 in	1.42 in	0.30 in	0.15 in
R-CTT-250-275-20	Aluminium	1/4-20	2.76 in	2.26 in	0.50 in	0.21 in
R-CTT-375-325-20	Aluminium	1/4-20	3.26 in	3.45 in	0.75 in	0.34 in



R-CTT-64-70-6

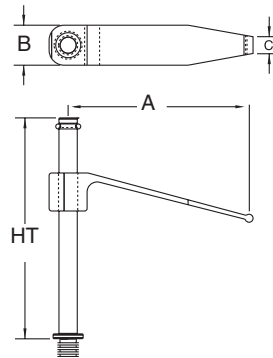

Spring wire clamps

For clamping of smaller workpieces, minimising the contact area on a workpiece and for the least possible obstruction.

Part number	Material	Thread	Height	A	B	Diameter
R-CW-25-25-4	Aluminium	M4	25.0 mm	31.3 mm	7.9 mm	1.6 mm
R-CW-50-50-4	Aluminium	M4	50.0 mm	49.7 mm	7.9 mm	1.6 mm
R-CW-25-25-6	Aluminium	M6	23.9 mm	31.3 mm	7.9 mm	1.6 mm
R-CW-50-50-6	Aluminium	M6	50.0 mm	49.7 mm	7.9 mm	1.6 mm
R-CW-1-1-20	Aluminium	1/4-20	0.94 in	1.23 in	0.31 in	0.06 in
R-CW-2-2-20	Aluminium	1/4-20	1.76 in	1.96 in	0.31 in	0.06 in



R-CW-50-50-4

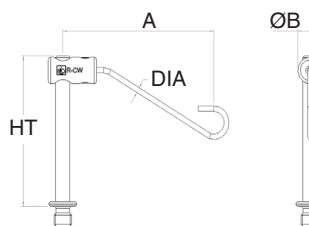

Soft tip spring wire clamps

With rubber-coated tips for light clamping of small workpieces, minimising the contact area on a workpiece and for least possible obstruction.

Part number	Material	Thread	Height	A	B	Diameter
R-CWT-25-25-4	Aluminium	M4	25.0 mm	31.3 mm	7.9 mm	1.6 mm
R-CWT-50-50-4	Aluminium	M4	50.0 mm	49.7 mm	7.9 mm	1.6 mm
R-CWT-25-25-6	Aluminium	M6	23.9 mm	31.3 mm	7.9 mm	1.6 mm
R-CWT-50-50-6	Aluminium	M6	50.0 mm	49.7 mm	7.9 mm	1.6 mm
R-CWT-1-1-20	Aluminium	1/4-20	0.94 in	1.23 in	0.31 in	0.06 in
R-CWT-2-2-20	Aluminium	1/4-20	1.76 in	1.96 in	0.31 in	0.06 in



R-CWT-25-25-4

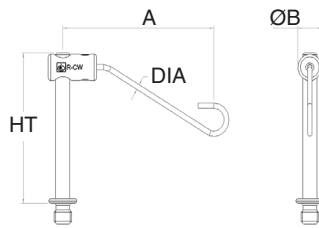

Plunger tip tension clamps

This tension clamp contains an adjustable rubber-tipped plunger to reach over the edge of a workpiece and apply a clamping force inside a recess.

Part number	Material	Thread	Height	A	B	C
R-CT-100P-83-6	Aluminium	M6	82.8 mm	92.0 mm	19.0 mm	8.5 mm
R-CT-100P-83-8	Aluminium	M8	82.8 mm	92.0 mm	19.0 mm	8.5 mm
R-CT-4P-325-20	Aluminium	1/4-20	3.26 in	3.62 in	0.75 in	0.33 in



R-CT-4P-325-20

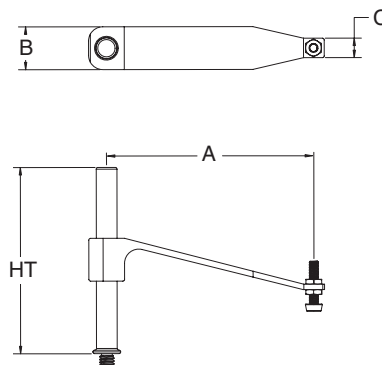

Screw pusher clamp

Use a screw pusher clamp for pushing and holding a workpiece against other fixturing components. Fits M6, M8 and 1/4-20 bases.

Part number	Height	A	B	C	D	Adjustments
R-CSP	76.2 mm/ 3.00 in	76.2 mm/ 3.00 in	25.4 mm/ 1.00 in	44.5 mm/ 1.75 in	44.4 mm/ 1.75 in	17.8 mm/ 0.70 in

NOTE: Includes M6, M8 and 1/4-20 socket cap head screws and washers.



R-CSP

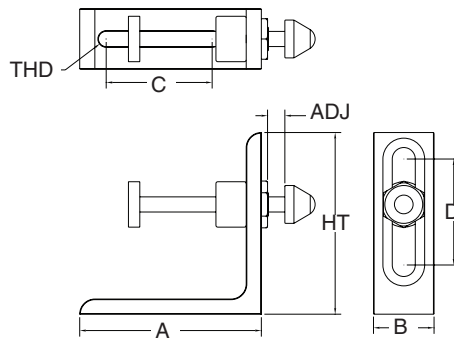

Pusher clamps

Use a pusher clamp to push a workpiece against standoffs or into a corner.

Part number	Thread	Height	A	B	C	D	Adjustments
R-CP-4	M4	31.2 mm	38.1 mm	19.0 mm	7.9 mm	12.7 mm	8.4 mm
R-CP-6	M6	31.2 mm	38.1 mm	19.0 mm	7.9 mm	12.7 mm	8.4 mm
R-CP-20	1/4-20	1.23 in	1.50 in	0.75 in	0.31 in	0.50 in	0.33 in

NOTE: Includes thumb screw and two interchangeable tips.



R-CP-4

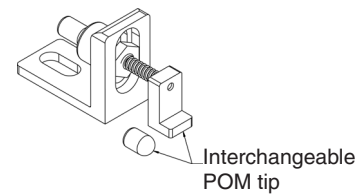
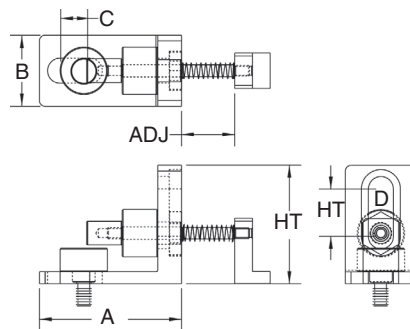

Interchangeable
POM tip

Micro vice clamps

Ideal for holding small workpieces. The jaws have a V notch for holding cylindrical and tubular workpieces.

Part number	Material	Thread	Height	A	B	Adjustments
R-CVM-4	Aluminium	M4	27.8 mm	39.8 mm	10.2 mm	13.0 mm
R-CVM-B-4 (with base)*	Aluminium	M4	35.1 mm	51.5 mm	16.0 mm	13.0 mm
R-CVM-6	Aluminium	M6	27.8 mm	39.8 mm	10.2 mm	13.0 mm
R-CVM-B-6 (with base)*	Aluminium	M6	37.8 mm	78.3 mm	20.0 mm	13.0 mm
R-CVM-20	Aluminium	1/4-20	1.09 in	1.57 in	0.40 in	0.51 in
R-CVM-B-20 (with base)*	Aluminium	1/4-20	1.34 in	3.09 in	0.75 in	0.51 in

NOTE: *Includes socket cap head screws and washers.



R-CVM-20



R-CVM-B-20

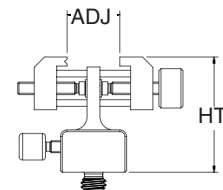
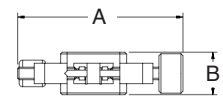

Mini vices

Use mini vices for clamping a small area of a part. The vice can be rotated 360° and then locked into position with a hex key.

Part number	Material	Thread	Height	A	B	Adjustments
R-CMV-4	Aluminium	M4	57.2 mm	31.8 mm	31.8 mm	15.0 mm
R-CMV-6	Aluminium	M6	57.2 mm	31.8 mm	31.8 mm	15.0 mm
R-CMV-8	Aluminium	M8	57.2 mm	31.8 mm	31.8 mm	15.0 mm
R-CMV-20	Aluminium	1/4-20	2.25 in	1.25 in	1.25 in	0.59 in

NOTE: Includes one straight jaw and one v-jaw as standard. Additional jaws can be purchased for use with any thread size mini vice by ordering part numbers: R-CMV-AJ (aluminium flat jaw) or R-CMV-VAJ (aluminium V-jaw).



R-CMV-6

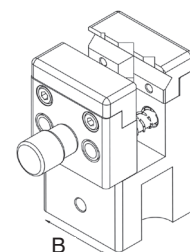
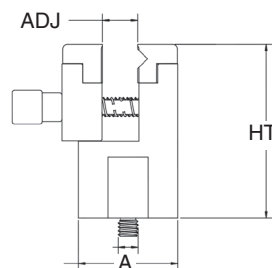

Tension clamp brackets

A tension clamp bracket attaches to a standoff and holds a tension clamp at an angle.

Part number	Material	Thread	Diameter	Height	A	B	C
R-CTB-25-6	Aluminium	M6	25.6 mm	6.4 mm	85.6 mm	38.1 mm	29.0 mm
R-CTB-25-8	Aluminium	M8	25.6 mm	6.4 mm	85.6 mm	38.1 mm	29.0 mm
R-CTB-1-20	Aluminium	1/4-20	1.01 in	0.25 in	3.37 in	1.50 in	1.14 in
R-CTB-19-6	Aluminium	M6	19.4 mm	10.0 mm	90.0 mm	25.0 mm	–
R-CTB-75-20	Aluminium	1/4-20	0.76 in	0.39 in	3.54 in	0.98 in	–



R-CTB-25-6

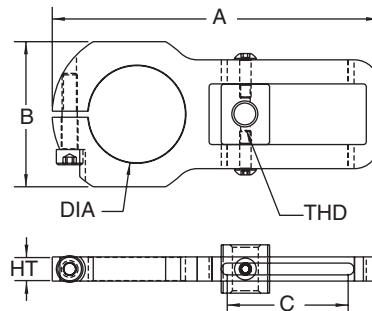

R-CTB-19-6

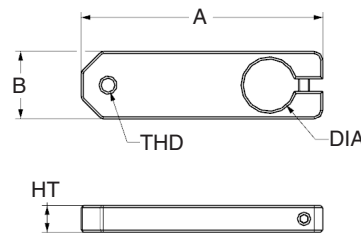

Centres

Centres are for holding cylindrical parts at each end on their inside diameters.

Part number	Material	Thread	Diameter	Height	A	B	C	D	Adjustments
R-CC-6	Aluminium	M4/M6/ 1/4-20	6.4 mm/ 0.25 in	27.9 mm/ 1.10 in	22.2 mm/ 0.87 in	50.8 mm/ 2.00 in	20.0 mm/ 0.79 in	9.6 mm/ 0.37 in	17.8 mm/ 0.70 in
R-CC-13	Aluminium	M4/M6/M8/ 1/4-20	12.7 mm/ 0.50 in	37.7 mm/ 1.48 in	38.1 mm/ 1.50 in	63.5 mm/ 2.50 in	25.0 mm/ 0.98 in	13.0 mm/ 0.51 in	38.1 mm/ 1.50 in
R-CC-25	Aluminium	M4/M6/M8/ 1/4-20	25.4 mm/ 1.00 in	54.0 mm/ 3.13 in	50.8 mm/ 2.00 in	76.2 mm/ 3.00 in	35.0 mm/ 1.38 in	19.1 mm/ 0.75 in	50.0 mm/ 1.97 in

NOTE: Includes both male and female centring options and socket cap head screws, delivered in pairs.



R-CC-6

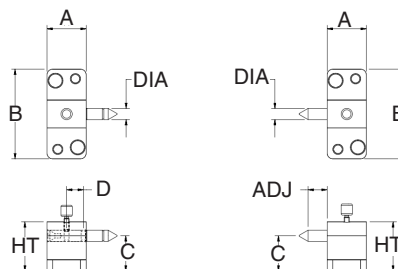

Micro centre

Adjustable to hold cylindrical workpieces up to 26 mm in length and 25.5 mm in diameter.

Part number	Thread	Pin Diameter	Height	A	B	C	Adjustments
R-CMC-4	M4	4.8 mm	30.0 mm	50.8 mm	31.8 mm	12.7 mm	26.0 mm



R-CMC-4

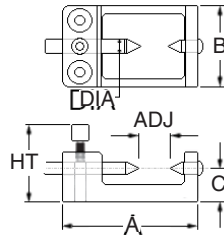

Micro V spring clamp

The clamp has an adjustable spring arm for different diameter workpieces and also an adjustable end stop. Two interchangeable clamp inserts are included (rubber for delicate workpieces and steel for general use).

Part number	Material	Thread	Height	A	B	Adjustments
R-CSVM-4	Aluminium	M4	48.6 mm	75.0 mm	12.5 mm	0° – 25°



R-CSVM-4

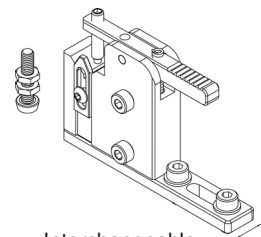
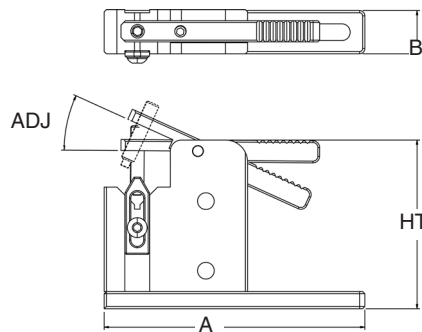

Interchangeable clamp inserts

Rotational angle vice

A flexible and versatile vice that allows variable orientation of your workpieces. Provides quick, convenient staging for a variety of workpieces and can be mounted directly on the rails of your comparator. Pivot range from 0° to 90° and rotational range of 360°.

Part number	Material	Thread	Height	A (Jaws)
R-CRAV	Aluminium	M4/M6/ 1/4-20	91.8 mm/ 3.61 in	32.0 mm/ 1.26 in

NOTE: Jaws are steel as standard but aluminium jaws are available as an option.



R-CRAV

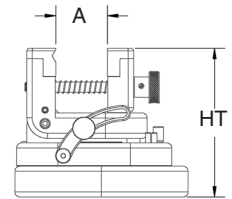
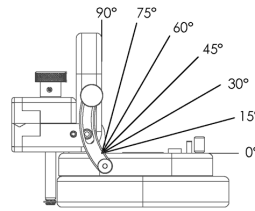

NOTE: Dowels included for clamping workpieces with minimum surface contact.

Spring pusher standoff clamps

A spring mounted, quick-locking mechanism, which is ideal for positioning workpieces and profile clamping.

Part number	Material	Thread	Diameter	Height	A
R-CSPS-1210-4	Aluminium	M4	12.0 mm	10.0 mm	4.0 mm
R-CSPS-1515-4	Aluminium	M4	15.0 mm	15.0 mm	6.7 mm
R-CSPS-1925-6	Steel	M6	19.1 mm	25.0 mm	10.7 mm
R-CSPS-1925-8	Steel	M8	19.1 mm	25.0 mm	10.7 mm
R-CSPS-751-20	Steel	1/4-20	0.75 in	1.00 in	0.42 in



R-CSPS-1210-4



R-CSPS-1925-6

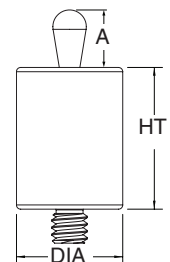

CMM plate clamp

Non-marking plastic clamp for securing 13 mm and 19 mm base plates to a CMM.

Part number	Material	Thread	Height	A	B	C	D	E
R-CPC-190	POM	M8/M10/ M12	34.0 mm	193.0 mm	32.0 mm	90.0 mm	18.2 mm	11.9 mm

NOTE: Includes screws for M8, M10 and M12 inserts.

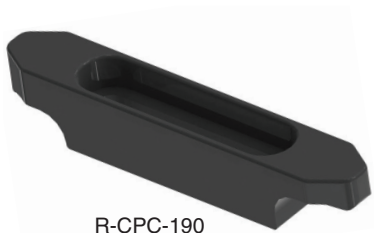

R-CPC-190

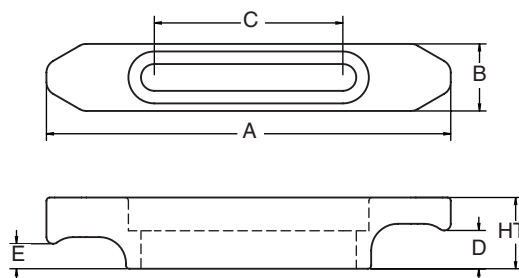

Hold down clamps

For more clamping force than standard tension clamps.

Part number	Height	A	B	C	D	Adjustments	Max. clamping force
R-CH-107	44.9 mm	127.7 mm	39.8 mm	37.7 mm	28.6 mm	14.6 mm	750 N
R-CH-138	53.3 mm	39.8 mm	51.3 mm	28.6 mm	18.3 mm	900 N	

NOTE: Includes M6, M8 and 1/4-20 socket cap head screws and washers.



R-CH-107



R-CH-138

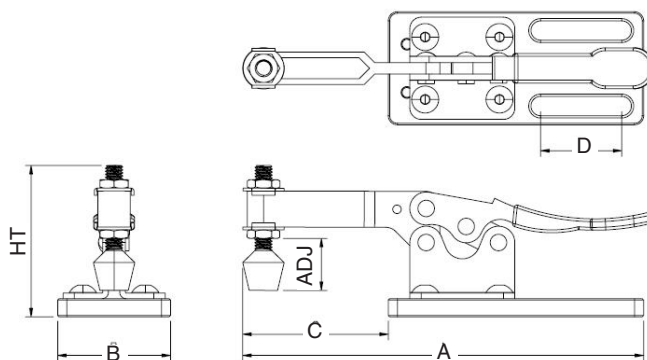



Magnets

Magnetic standoffs

Use a magnetic standoff to hold ferrous workpieces.

Part number	Thread	Diameter	Height
R-M-6-4	M4	6.3 mm	25.0 mm
R-M-13-4	M4	12.7 mm	25.0 mm
R-M-13-6	M6	12.7 mm	25.0 mm
R-M-19-6	M6	19.1 mm	25.0 mm
R-M-25-6	M6	25.0 mm	25.0 mm
R-M-13-8	M8	12.7 mm	25.0 mm
R-M-19-8	M8	19.1 mm	25.0 mm
R-M-25-8	M8	25.0 mm	25.0 mm
R-M-50-20	1/4-20	0.50 in	1.00 in
R-M-75-20	1/4-20	0.75 in	1.00 in
R-M-1-20	1/4-20	1.00 in	1.00 in



R-M-19-6



R-M-25-8

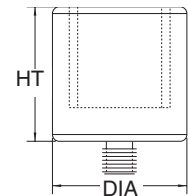

Magnetic pin standoffs

Use magnetic pin standoffs to hold and locate ferrous workpieces.

Part number	Thread	Diameter	Height	A	B
R-MP-6-4	M4	6.4 mm	25.0 mm	3.8 mm	1.5 mm
R-MP-13-4	M4	12.7 mm	25.0 mm	3.8 mm	3.2 mm
R-MP-13-6	M6	12.7 mm	25.0 mm	3.8 mm	3.2 mm
R-MP-19-6	M6	19.1 mm	25.0 mm	3.8 mm	3.2 mm
R-MP-25-6	M6	25.4 mm	25.0 mm	3.8 mm	3.2 mm
R-MP-13-8	M8	12.7 mm	25.0 mm	3.8 mm	3.2 mm
R-MP-19-8	M8	19.1 mm	25.0 mm	3.8 mm	3.2 mm
R-MP-25-8	M8	25.4 mm	25.0 mm	3.8 mm	3.2 mm
R-MP-50-20	1/4-20	0.50 in	1.00 in	0.15 in	0.13 in
R-MP-75-20	1/4-20	0.75 in	1.00 in	0.15 in	0.13 in
R-MP-1-20	1/4-20	1.00 in	1.00 in	0.15 in	0.13 in



R-MP-19-6



R-MP-13-8

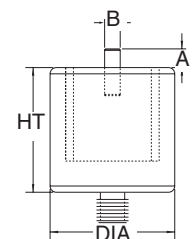

Magnetic mini V block

Designed to hold ferrous cylindrical workpieces in a V, without the need for extra tension clamps.

Part number	Height	A	B
R-NTM-1	27.9 mm/ 1.10 in	27.9 mm/ 1.10 in	24.9 mm/ 0.98 in

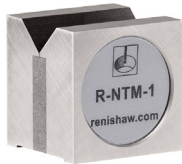

R-NTM-1

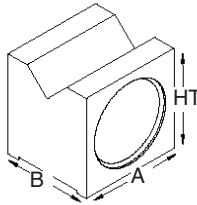

V magnets

Use V magnets for holding ferrous cylindrical workpieces and tubing.

Part number	Thread	Diameter	Height
R-MV-13-6	M6	13.0 mm	25.0 mm
R-MV-19-6	M6	19.1 mm	25.0 mm
R-MV-25-6	M6	25.0 mm	25.0 mm
R-MV-32-6	M6	32.0 mm	25.0 mm
R-MV-13-8	M8	13.0 mm	25.0 mm
R-MV-19-8	M8	19.1 mm	25.0 mm
R-MV-25-8	M8	25.0 mm	25.0 mm
R-MV-32-8	M8	32.0 mm	25.0 mm
R-MV-50-20	1/4-20	0.50 in	1.00 in
R-MV-75-20	1/4-20	0.75 in	1.00 in
R-MV-1-20	1/4-20	1.00 in	1.00 in
R-MV-125-20	1/4-20	1.25 in	1.00 in



R-MV-13-6



R-MV-25-8

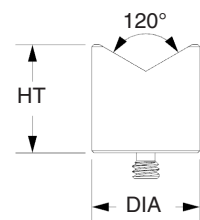

NOTE: V magnets can be combined with an adjustable height stand (available on page 32) to be used as a means to control the orientation of the V. They can also be used with a slide to add rotation of the V.

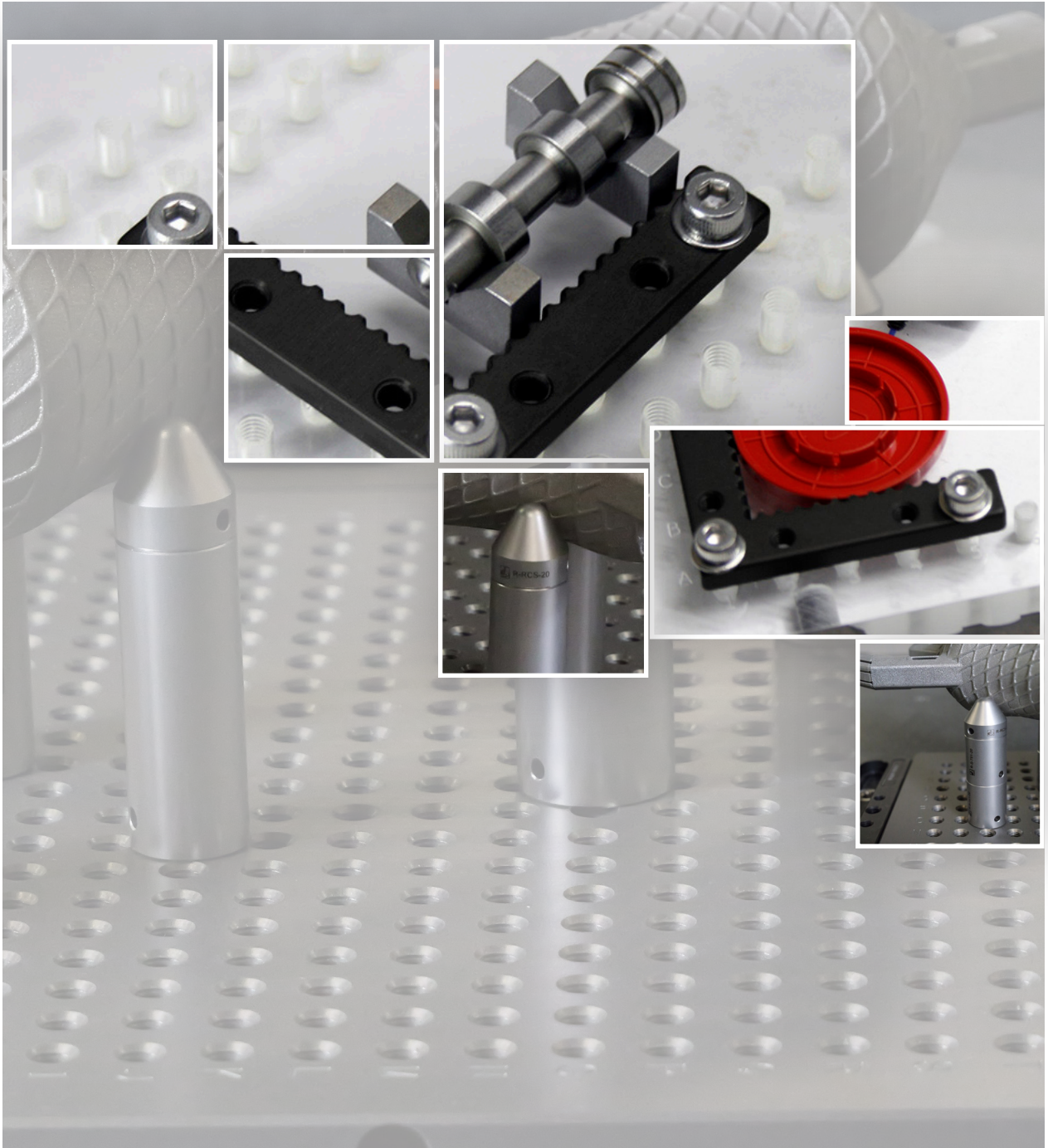

Miscellaneous

Find the ideal solution for resting or locating workpieces

Cones

Use a cone to rest a workpiece on a rounded point for single-point contact.

Part number	Material	Thread	Diameter	Height
R-RCD-19-6	POM	M6	19.1 mm	20.0 mm
R-RCS-19-6	Steel	M6	19.1 mm	20.0 mm
R-RCA-25-6	Aluminium	M6	25.4 mm	25.0 mm
R-RCD-19-8	POM	M8	19.1 mm	20.0 mm
R-RCS-19-8	Steel	M8	19.1 mm	20.0 mm
R-RCA-25-8	Aluminium	M8	25.4 mm	25.0 mm
R-RCS-25-8	Steel	M8	25.4 mm	25.0 mm
R-RCD-75-20	POM	1/4-20	0.75 in	0.75 in
R-RCS-75-20	Steel	1/4-20	0.75 in	0.75 in
R-RCA-1-20	Aluminium	1/4-20	1.00 in	1.00 in



POM
R-RCD-19-6

Steel
R-RCS-19-6

Aluminium
R-RCA-25-6

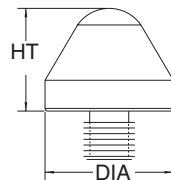

Resting pins

Use resting pins to rest a workpiece on a rounded point.

Part number	Material	Thread	Diameter	Height	A
R-RPD-4	POM	M4	6.4 mm	5.0 mm	1.6 mm
R-RPA-4	Aluminium	M4	6.4 mm	5.0 mm	1.6 mm
R-RPD-6	POM	M6	9.5 mm	10.0 mm	1.7 mm
R-RPS-6	Steel	M6	9.5 mm	10.0 mm	3.1 mm
R-RPD-20	POM	1/4-20	0.37 in	0.37 in	0.07 in
R-RPS-20	Steel	1/4-20	0.37 in	0.37 in	0.07 in



Aluminium
R-RPA-4

Steel
R-RPS-6

POM
R-RPD-6

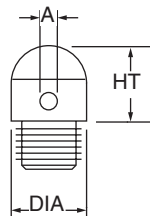

Wedge stops

Wedge stop(s), typically used in pairs, will locate and hold down a workpiece and restrict the workpiece from lifting.

Part number	Material	Thread	Diameter	A	B
R-WS-1010-4	Aluminium	M4	10.0 mm	5.0 mm	15.0 mm
R-WS-915-6	Aluminium	M6	15.0 mm	5.9 mm	20.0 mm
R-WS-37550-20	Aluminium	1/4-20	0.57 in	0.25 in	0.75 in
R-WS-1316-8	Aluminium	M8	19.1 mm	8.7 mm	25.0 mm



R-WS-1316-8

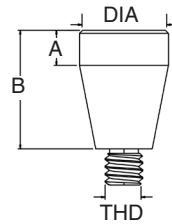

Screws and adaptors

Details of replacement parts are in the table below.

Part number	Thread	Diameter	Height
Thumb screws			
AATK-6	M6	21.0 mm	15.0 mm
AATK-20	1/4-20	0.83 in	0.59 in
Screws			
ATS-4	M4	12.6 mm	15.4 mm
Adaptor			
AAS-4	M4	8.0 mm	13.3 mm
AAS-6	M6	8.0 mm	13.3 mm
AAS-8	M8	11.0 mm	16.8 mm
AAS-20	1/4-20	0.31 in	0.52 in



AATK-6



ATS-4



AAS-6

Corner viewers

Use corner viewers to locate a workpiece in a corner. The serrations allow back lighting along the sides of the workpiece.

Part number	Material	Thread	Height	A	B	C
R-VC-5050-4	Aluminium	M4	5.0 mm	50.0 mm	50.0 mm	10.0 mm
R-VC-7575-6	Aluminium	M6	7.0 mm	82.6 mm	82.6 mm	19.0 mm
R-VC-33-20	Aluminium	1/4-20	0.25 in	3.25 in	3.25 in	0.75 in

NOTE: Includes socket cap head screws.

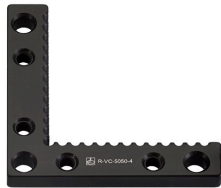

R-VC-5050-4

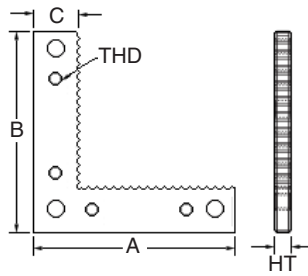

Vertical base plate

Use a vertical base plate for fixturing workpieces vertically.

Part number	Material	Thread	Height	A	B	Hole spacing
R-PCV-507540-10-4	Aluminium	M4	63.5 mm	76.2 mm	38.1 mm	10.0 mm



R-PCV-507540-10-4

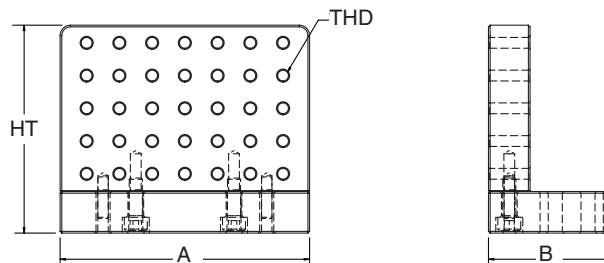

NOTE: Includes socket cap head screws.

Micro V block

Use a micro V block to hold cylindrical workpieces less than 20 mm in diameter.

Part number	Material	Height	A	B	C
R-VMB-20510	Steel	10.0 mm/ 0.39 in	20.0 mm/ 0.79 in	5.0 mm/ 0.20 in	3.0 mm/ 0.12 in

NOTE: Supplied in pairs.



R-VMB-20510

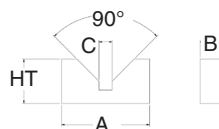

Tooling balls

Use tooling balls to reference CMM co-ordinates to a program or workpiece.

Part number	Thread	Diameter	Height	ØA
R-STB-13-6	M6	19.1 mm	41.5 mm	12.7 mm
R-STB-13-8	M8	19.1 mm	41.5 mm	12.7 mm
R-STB-50-20	1/4-20	0.75 in	1.65 in	0.50 in



R-STB-13-6

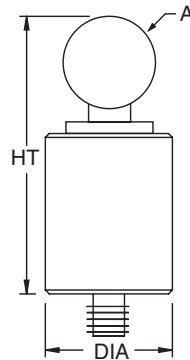

Metrology table adaptor plate

The metrology table adaptor plate allows for an articulating CMM arm to be fitted to any Renishaw fixture base plate or metrology table base plate.

Part number	Bolt hole size	Height	A	B
R-PAACU	M6/M8/ 1/4-20	19.0 mm/ 0.75 in	200.0 mm/ 7.87 in	200.0 mm/ 7.87 in



R-PAACU

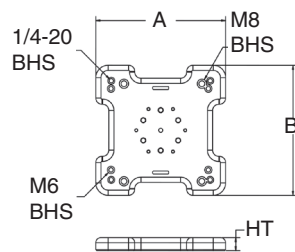

NOTE: Includes M6, M8 and 1/4-20 socket cap head screws.

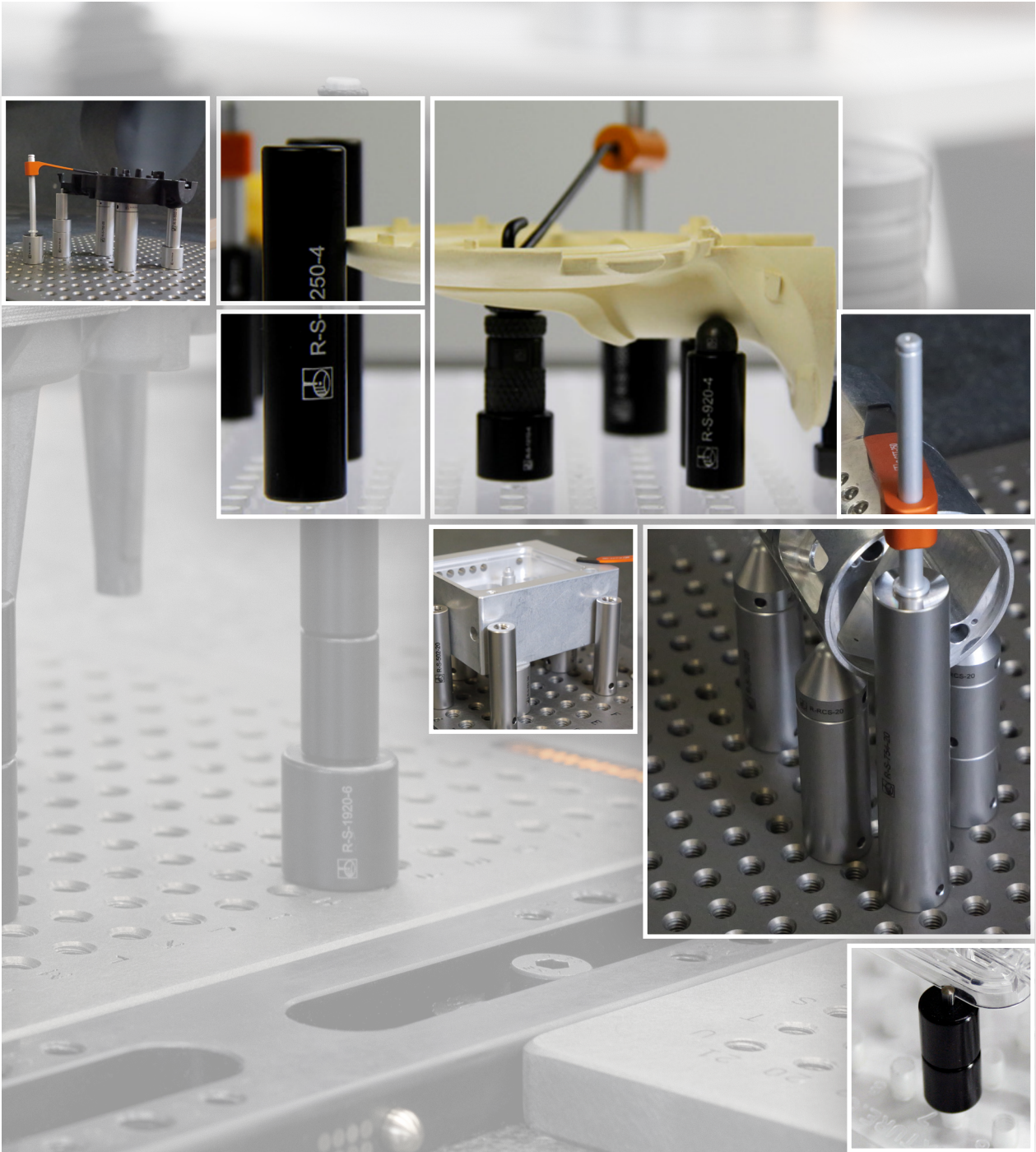

Standoffs

Elevate and locate your workpiece into the machine's working volume with our selection of standoffs

Available to order in M4, M6, M8, and 1/4-20 thread sizes. Component information continues overleaf.

Part number	Thread	Diameter	Height
M4 standoffs			
R-S-65-4*	M4	6.0 mm	5.0 mm
R-S-610-4*	M4	6.0 mm	10.0 mm
R-S-615-4*	M4	6.0 mm	15.0 mm
R-S-620-4*	M4	6.0 mm	20.0 mm
R-S-625-4*	M4	6.0 mm	25.0 mm
R-S-95-4*	M4	9.0 mm	5.0 mm
R-S-910-4	M4	9.0 mm	10.0 mm
R-S-915-4	M4	9.0 mm	15.0 mm
R-S-920-4	M4	9.0 mm	20.0 mm
R-S-925-4	M4	9.0 mm	25.0 mm
R-S-950-4	M4	9.0 mm	50.0 mm
R-S-125-4*	M4	12.0 mm	5.0 mm
R-S-1210-4	M4	12.0 mm	10.0 mm
R-S-1215-4	M4	12.0 mm	15.0 mm
R-S-1220-4	M4	12.0 mm	20.0 mm
R-S-1225-4	M4	12.0 mm	25.0 mm
R-S-1250-4	M4	12.0 mm	50.0 mm

NOTE: M4 standoffs are made of aluminium.

*Does not have a threaded top.

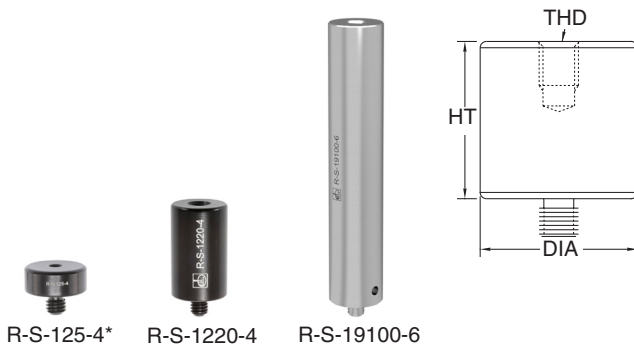

R-S-125-4*

R-S-1220-4

R-S-19100-6

Part number	Thread	Diameter	Height
M6 standoffs			
R-S-610-6*	M6	6.0 mm	10.0 mm
R-S-625-6*	M6	6.0 mm	25.0 mm
R-S-95-6*	M6	9.5 mm	5.0 mm
R-S-910-6	M6	9.5 mm	10.0 mm
R-S-915-6	M6	9.5 mm	15.0 mm
R-S-920-6	M6	9.5 mm	20.0 mm
R-S-925-6	M6	9.5 mm	25.0 mm
R-S-1310-6	M6	12.7 mm	10.0 mm
R-S-1315-6	M6	12.7 mm	15.0 mm
R-S-1320-6	M6	12.7 mm	20.0 mm
R-S-1325-6	M6	12.7 mm	25.0 mm
R-S-1350-6	M6	12.7 mm	50.0 mm
R-S-13100-6	M6	12.7 mm	100.0 mm
R-S-13150-6	M6	12.7 mm	150.0 mm
R-S-1910-6	M6	19.1 mm	10.0 mm
R-S-1915-6	M6	19.1 mm	15.0 mm
R-S-1920-6	M6	19.1 mm	20.0 mm
R-S-1925-6	M6	19.1 mm	25.0 mm
R-S-1950-6	M6	19.1 mm	50.0 mm
R-S-19100-6	M6	19.1 mm	100.0 mm
R-S-19150-6	M6	19.1 mm	150.0 mm
R-S-2515-6	M6	25.4 mm	15.0 mm
R-S-2520-6	M6	25.4 mm	20.0 mm
R-S-2525-6	M6	25.4 mm	25.0 mm
R-S-2550-6	M6	25.4 mm	50.0 mm
R-S-25100-6	M6	25.4 mm	100.0 mm
R-S-25150-6	M6	25.4 mm	150.0 mm

NOTE: M6 standoffs are made of steel.

*Does not have a threaded top.

Part number	Thread	Diameter	Height
M8 standoffs			
R-S-1315-8	M8	12.7 mm	15.0 mm
R-S-1320-8	M8	12.7 mm	20.0 mm
R-S-1325-8	M8	12.7 mm	25.0 mm
R-S-1350-8	M8	12.7 mm	50.0 mm
R-S-13100-8	M8	12.7 mm	100.0 mm
R-S-1915-8	M8	19.1 mm	15.0 mm
R-S-1920-8	M8	19.1 mm	20.0 mm
R-S-1925-8	M8	19.1 mm	25.0 mm
R-S-1950-8	M8	19.1 mm	50.0 mm
R-S-19100-8	M8	19.1 mm	100.0 mm
R-S-19150-8	M8	19.1 mm	150.0 mm
R-S-2520-8	M8	25.4 mm	20.0 mm
R-S-2525-8	M8	25.4 mm	25.0 mm
R-S-2550-8	M8	25.4 mm	50.0 mm
R-S-25100-8	M8	25.4 mm	100.0 mm
R-S-25150-8	M8	25.4 mm	150.0 mm
R-S-3825-8	M8	38.1 mm	25.0 mm
R-S-3850-8	M8	38.1 mm	50.0 mm
R-S-38150-8	M8	38.1 mm	150.0 mm

NOTE: M8 standoffs are made of steel.

Part number	Thread	Diameter	Height
1/4-20 standoffs			
R-S-2550-20*	1/4-20	0.25 in	0.50 in
R-S-251-20*	1/4-20	0.25 in	1.00 in
R-S-37525-20*	1/4-20	0.375 in	0.25 in
R-S-37550-20	1/4-20	0.375 in	0.50 in
R-S-37575-20	1/4-20	0.375 in	0.75 in
R-S-3751-20	1/4-20	0.375 in	1.00 in
R-S-5025-20*	1/4-20	0.50 in	0.25 in
R-S-5050-20	1/4-20	0.50 in	0.50 in
R-S-5075-20	1/4-20	0.50 in	0.75 in
R-S-501-20	1/4-20	0.50 in	1.00 in
R-S-502-20	1/4-20	0.50 in	2.00 in
R-S-504-20	1/4-20	0.50 in	4.00 in
R-S-506-20	1/4-20	0.50 in	6.00 in
R-S-7550-20	1/4-20	0.75 in	0.50 in
R-S-7575-20	1/4-20	0.75 in	0.75 in
R-S-751-20	1/4-20	0.75 in	1.00 in
R-S-752-20	1/4-20	0.75 in	2.00 in
R-S-754-20	1/4-20	0.75 in	4.00 in
R-S-756-20	1/4-20	0.75 in	6.00 in
R-S-150-20	1/4-20	1.00 in	0.50 in
R-S-175-20	1/4-20	1.00 in	0.75 in
R-S-11-20	1/4-20	1.00 in	1.00 in
R-S-12-20	1/4-20	1.00 in	2.00 in
R-S-14-20	1/4-20	1.00 in	4.00 in
R-S-16-20	1/4-20	1.00 in	6.00 in

NOTE: All 1/4-20 are made of steel. *Does not have a threaded top.

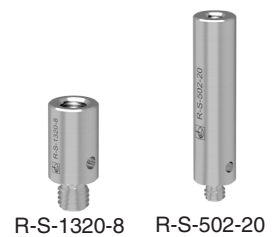
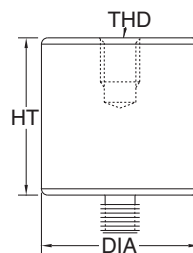

Pin standoffs

Use pin standoffs to elevate and locate a workpiece against the pin.

Part number	Material	Thread	Diameter	Height	A	B
R-SP-610-4	Aluminium	M4	6.0 mm	10.0 mm	2.5 mm	2.0 mm
R-SP-910-4	Aluminium	M4	9.0 mm	10.0 mm	2.5 mm	2.0 mm
R-SP-1210-4	Aluminium	M4	12.0 mm	10.0 mm	2.5 mm	2.0 mm
R-SP-610-6	Aluminium	M6	6.4 mm	10.0 mm	4.2 mm	1.5 mm
R-SP-910-6	Steel	M6	9.5 mm	10.0 mm	4.2 mm	1.5 mm
R-SP-1325-6	Steel	M6	12.7 mm	25.0 mm	4.2 mm	3.0 mm
R-SP-1925-6	Steel	M6	19.1 mm	25.0 mm	4.2 mm	3.0 mm
R-SP-2525-6	Steel	M6	25.4 mm	25.0 mm	4.2 mm	3.0 mm
R-SP-1325-8	Steel	M8	12.7 mm	25.0 mm	4.2 mm	3.0 mm
R-SP-1925-8	Steel	M8	19.1 mm	25.0 mm	4.2 mm	3.0 mm
R-SP-2525-8	Steel	M8	25.4 mm	25.0 mm	4.2 mm	3.0 mm
R-SP-501-20	Steel	1/4-20	0.50 in	1.00 in	0.17 in	0.12 in
R-SP-751-20	Steel	1/4-20	0.75 in	1.00 in	0.17 in	0.12 in
R-SP-2550-20	Steel	1/4-20	0.25 in	0.50 in	0.17 in	0.06 in
R-SP-37550-20	Steel	1/4-20	0.375 in	0.50 in	0.17 in	0.06 in
R-SP-11-20	Steel	1/4-20	1.00 in	1.00 in	0.17 in	0.12 in

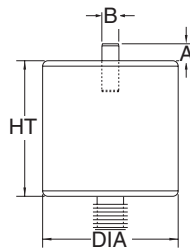

NOTE: Pin height dimension tolerance ± 0.5 mm.

Polyoxymethylene (POM) standoffs

Use POM standoffs to elevate and locate a workpiece using a non-marking material.

Part number	Material	Thread	Diameter	Height
R-SD-610-4*	POM	M4	6.0 mm	10.0 mm
R-SD-910-4	POM	M4	9.0 mm	10.0 mm
R-SD-1210-4	POM	M4	12.0 mm	10.0 mm
R-SD-925-6	POM	M6	10.0 mm	25.0 mm
R-SD-1325-6	POM	M6	13.0 mm	25.0 mm
R-SD-1925-6	POM	M6	19.0 mm	25.0 mm
R-SD-3751-20	POM	1/4-20	0.39 in	1.00 in
R-SD-501-20	POM	1/4-20	0.51 in	1.00 in
R-SD-751-20	POM	1/4-20	0.75 in	1.00 in

NOTE: *Does not have a threaded top.



POM pin standoffs

Use to elevate and locate a workpiece against a pin using a non-marking material.

Part number	Material	Thread	Diameter	Height	A	B
R-SPD-910-4	POM	M4	9.0 mm	10.0 mm	2.5 mm	2.0 mm
R-SPD-1325-6	POM	M6	12.5 mm	25 mm	4.2 mm	3.0 mm
R-SPD-501-20	POM	1/4-20	0.50 in	0.98 in	0.17 in	0.12 in



NOTE: Pin height dimension tolerance ± 0.5 mm.

Standoff adaptors

Use standoff adaptors to attach components of one thread size to a plate of a different thread size.

Part number	Male thread	Diameter	Height	A (female top thread)
R-SA-20-4	M4	19.1 mm/ 0.75 in	15.0 mm/ 0.59 in	1/4-20
R-SA-6-4	M4	19.1 mm	15.0 mm	M6
R-SA-8-4	M4	19.1 mm	25.0 mm	M8
R-SA-4-6	M6	9.5 mm	15.0 mm	M4
R-SA-8-6	M6	25.4 mm	25.0 mm	M8
R-SA-20-6	M6	25.4 mm/ 1.00 in	25.0 mm/ 0.98 in	1/4-20
R-SA-6-8	M8	25.4 mm	25.0 mm	M6
R-SA-20-8	M8	25.4 mm/ 1.00 in	25.0 mm/ 0.98 in	1/4-20
R-SA-4-20	1/4-20	9.5 mm/ 0.375 in	12.7 mm/ 0.50 in	M4
R-SA-6-20	1/4-20	25.4 mm/ 1.00 in	25.4 mm/ 1.00 in	M6
R-SA-8-20	1/4-20	25.4 mm/ 1.00 in	25.4 mm/ 1.00 in	M8



R-SA-6-8

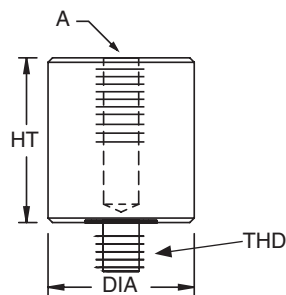

Rotator standoffs

Use rotator standoffs to secure workpieces against stops/supports.

Part number	Thread	Diameter	Height	Adjustments
R-SR-2525-6	M6	25.4 mm	25.0 mm	19.5 mm
R-SR-11-20	1/4-20	1.00 in	0.98 in	0.77 in



R-SR-2525-6

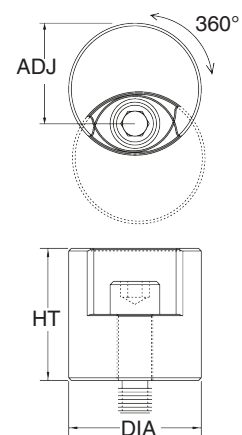

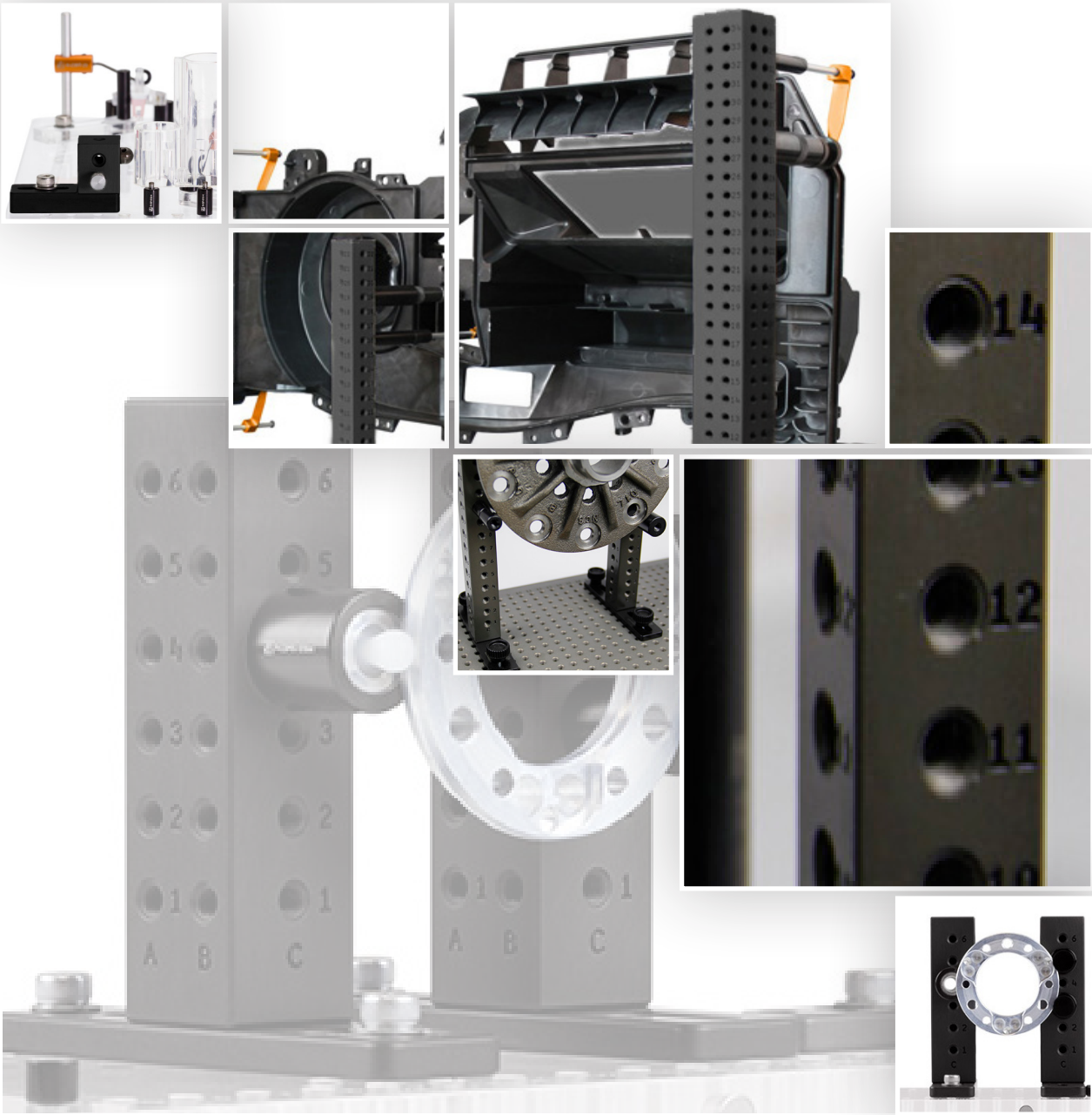

Towers

Towers can be used to fixture large workpieces or to hold a workpiece vertically.

Part number	Material	Thread	Height	A	B	C	Thread rows
R-T-2080-4	Aluminium	M4	80.0 mm	75.0 mm	20.0 mm	20.0 mm	2 / 1*
R-T-25150-6	Aluminium	M6	150.0 mm	127.0 mm	25.4 mm	25.0 mm	1
R-T-25300-6	Aluminium	M6	300.0 mm	127.0 mm	25.4 mm	25.0 mm	1
R-T-35300-6	Aluminium	M6	300.0 mm	152.4 mm	50.8 mm	35.0 mm	2
R-T-35450-6	Aluminium	M6	450.0 mm	152.4 mm	50.8 mm	35.0 mm	2
R-T-50600-6	Aluminium	M6	600.0 mm	152.4 mm	50.8 mm	50.0 mm	2
R-T-50750-6	Aluminium	M6	750.0 mm	152.4 mm	50.8 mm	50.0 mm	2
R-T-25150-8	Aluminium	M8	150.0 mm	127.0 mm	25.4 mm	25.0 mm	1
R-T-25300-8	Aluminium	M8	300.0 mm	127.0 mm	25.4 mm	25.0 mm	1
R-T-35300-8	Aluminium	M8	300.0 mm	152.4 mm	50.8 mm	35.0 mm	2 / 1*
R-T-35450-8	Aluminium	M8	450.0 mm	152.4 mm	50.8 mm	35.0 mm	2 / 1*
R-T-50600-8	Aluminium	M8	600.0 mm	152.4 mm	50.8 mm	50.0 mm	2
R-T-50750-8	Aluminium	M8	750.0 mm	152.4 mm	50.8 mm	50.0 mm	2
R-T-16-20	Aluminium	1/4-20	6.00 in	5.00 in	1.00 in	1.00 in	1
R-T-112-20	Aluminium	1/4-20	12.00 in	5.00 in	1.00 in	1.00 in	1
R-T-1512-20	Aluminium	1/4-20	12.00 in	6.00 in	2.00 in	1.50 in	2
R-T-1518-20	Aluminium	1/4-20	18.00 in	6.00 in	2.00 in	1.50 in	2
R-T-224-20	Aluminium	1/4-20	24.00 in	6.00 in	2.00 in	2.00 in	2
R-T-230-20	Aluminium	1/4-20	30.00 in	6.00 in	2.00 in	2.00 in	2

NOTE: Includes socket cap head screws. * Two sides have two rows of holes and two sides have one row of holes in the centre.

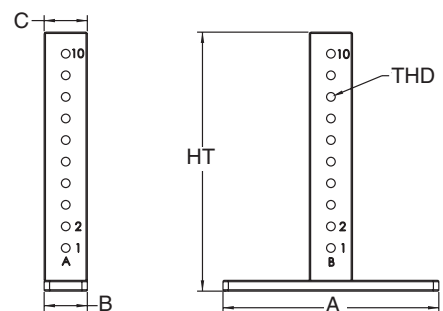
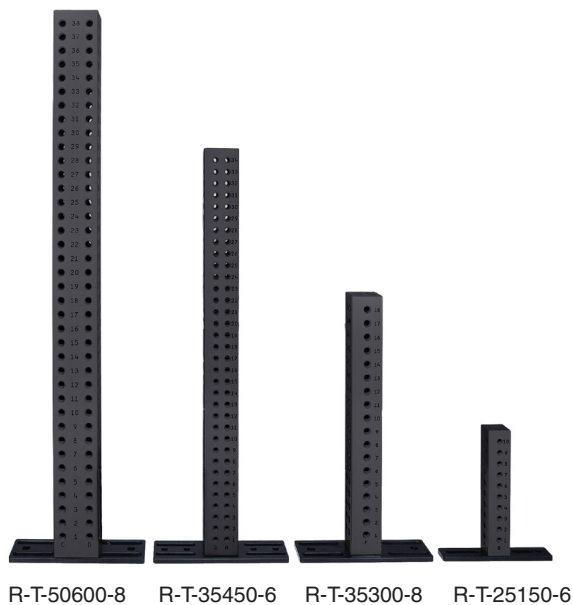

Tower blocks

Use tower blocks to mount other fixturing components at planes of 90° to standard mounting holes.

Part number	Material	Thread	Height	A	B	C	D
R-TB-1619-4	Aluminium	M4	25.0 mm	41.3 mm	15.9 mm	15.9 mm	15.0 mm
R-TB-2025-6	Aluminium	M6	35.0 mm	70.0 mm	20.0 mm	20.0 mm	34.6 mm
R-TB-2530-8	Aluminium	M8	40.0 mm	88.9 mm	25.0 mm	25.0 mm	44.9 mm
R-TB-751-20	Aluminium	1/4-20	1.25 in	2.75 in	0.75 in	0.75 in	1.50 in

NOTE: Includes socket cap head screws.



R-TB-2530-8

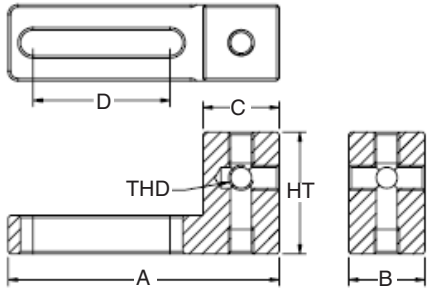

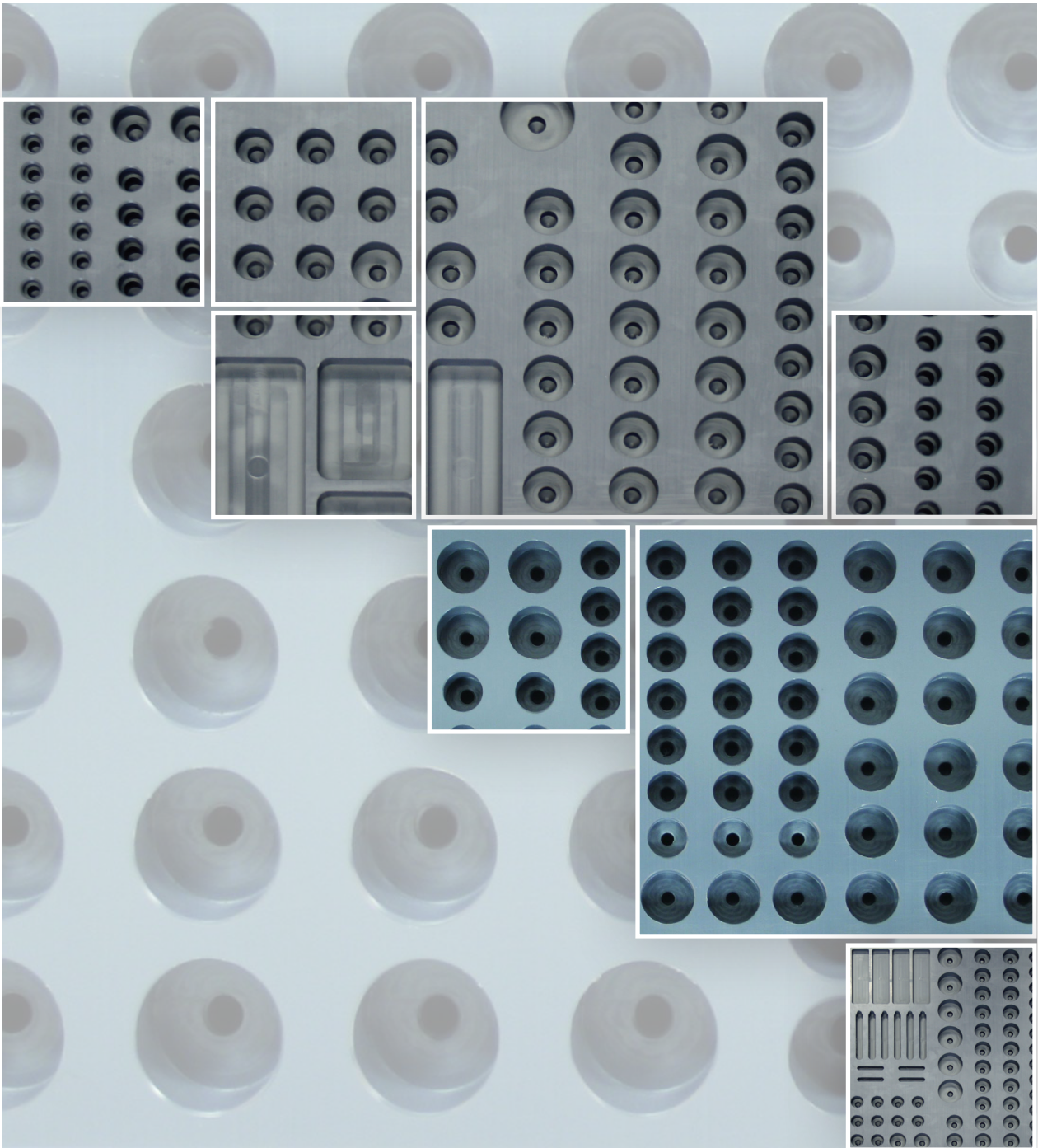

Trays

Use trays to hold and organise fixturing components.

Medium component tray

Part number	Thread	Height	Length	Width
R-TC-500200	M6/M8/ 1/4-20	25 mm/ 1 in	502 mm/ 20 in	197 mm/ 8 in



R-TC-500200

Small component tray

Part number	Thread	Height	Length	Width
R-TC-300190-4	M4	25 mm	305 mm	190 mm
R-TC-300190-6	M6	25 mm	305 mm	190 mm
R-TC-300190-20	1/4-20	1 in	13 in	7 in
R-TC-300200*	M6/M8/ 1/4-20	25 mm/ 1 in	305 mm/ 13 in	190 mm/ 7 in

NOTE: * Is a multi-purpose thread component tray.

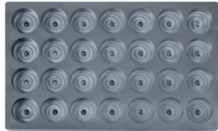

R-TC-300200

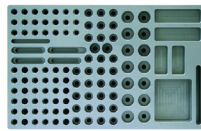

R-TC-300190-20

Component storage box

A compartment box to hold and organise components.

Part number	Height	Length	Width
R-BC10	40 mm/ 2 in	143 mm/ 6 in	190 mm/ 7 in



R-BC10

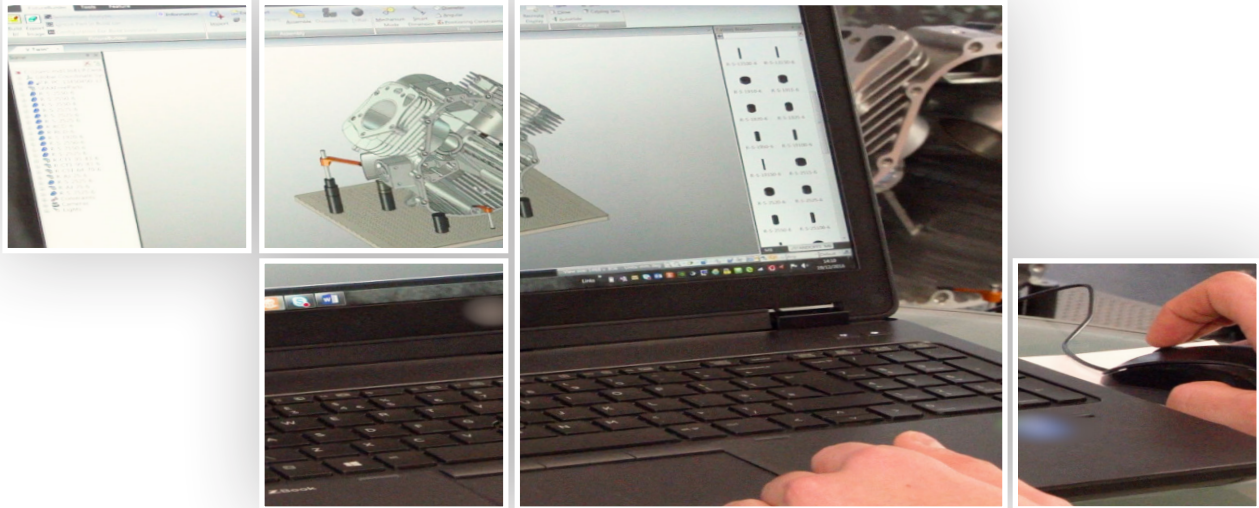

3D fixture modelling software

Renishaw's FixtureBuilder is a 3D fixture modelling software for creating fixturing set-ups. It offers the 'Build it' feature to generate work instructions and support off-line programming for CMM, Equator™ gauging, and vision inspection.

We offer license codes or dongles.

Part number	Description
CS-SOF-SW-17-FBCU	FixtureBuilder license sold with network licence manager software
CS-SOF-SUBS-17-FBNU	Annual subscription, sent as an activation code for named user
CS-SOF-SW-17-FBNRMS	Network license manager software controlled license
CS-SOF-SW-17-FBNU	FixtureBuilder license distributed via a download
CS-SOF-SW-17-FBTRANS	Additional translator module for CATIA, ProE, UGNX, Solidworks and Inventor. Distributed via download
A-6490-0052	FixtureBuilder license for offline users, distributed on a dongle, transferable between work stations
A-6490-0055	Network license manager hardware dongle controlled

www.renishaw.com/contact



#renishaw

UK  +44 (0) 1453 524524  uk@renishaw.com

USA  +1 847 286 9953

 usa@renishaw.com

© 2019–2026 Renishaw plc. All rights reserved. This document may not be copied or reproduced in whole or in part, or transferred to any other media or language by any means, without the prior written permission of Renishaw.

RENISHAW® and the probe symbol are registered trade marks of Renishaw plc. Renishaw product names, designations and the mark 'apply innovation' are trade marks of Renishaw plc or its subsidiaries. Other brand, product or company names are trade marks of their respective owners.

WHILE CONSIDERABLE EFFORT WAS MADE TO VERIFY THE ACCURACY OF THIS DOCUMENT AT PUBLICATION, ALL WARRANTIES, CONDITIONS, REPRESENTATIONS AND LIABILITY, HOWSOEVER ARISING, ARE EXCLUDED TO THE EXTENT PERMITTED BY LAW. RENISHAW RESERVES THE RIGHT TO MAKE CHANGES TO THIS DOCUMENT AND TO THE EQUIPMENT, AND/OR SOFTWARE AND THE SPECIFICATION DESCRIBED HEREIN WITHOUT OBLIGATION TO PROVIDE NOTICE OF SUCH CHANGES.

Renishaw plc. Registered in England and Wales. Company no: 1106260. Registered office: New Mills, Wotton-under-Edge, Glos, GL12 8JR, UK.

Part number: H-1000-9970-05-C

Issued: 02.2026